



# 7800R4x8-ACS Series HD/3G 4X8 Protection Switch with Advanced Clean Switch Processing User Manual

© Copyright 2016-2019

**EVERTZ MICROSYSTEMS LTD.**

5292 John Lucas Drive  
Burlington, Ontario  
Canada L7L 5Z9

Phone: +1 905-335-3700  
Sales Fax: +1 905-335-3573  
Tech Support Phone: +1 905-335-7570  
Tech Support Fax: +1 905-335-7571

Internet: Sales: [sales@evertz.com](mailto:sales@evertz.com) Tech Support: [service@evertz.com](mailto:service@evertz.com)  
Web Page: [www.evertz.com](http://www.evertz.com) Twitter: [@EvertzTV](https://twitter.com/EvertzTV)



Version 2.1, June 2019

The material contained in this manual consists of information that is the property of Evertz Microsystems and is intended solely for the use of purchasers of the 7800R4x8-ACS series product. Evertz Microsystems expressly prohibits the use of this manual for any purpose other than the operation of the 7800R4x8-ACS series product. Due to on going research and development, features and specifications in this manual are subject to change without notice.

All rights reserved. No part of this publication may be reproduced without the express written permission of Evertz Microsystems Ltd. Copies of this manual can be ordered from your Evertz dealer or from Evertz Microsystems.

*This page left intentionally blank*

## IMPORTANT SAFETY INSTRUCTIONS

	The lightning flash with arrowhead symbol within an equilateral triangle is intended to alert the user to the presence of uninsulated “Dangerous voltage” within the product’s enclosure that may be of sufficient magnitude to constitute a risk of electric shock to persons.
	The exclamation point within an equilateral triangle is intended to alert the user to the presence of important operating and maintenance (Servicing) instructions in the literature accompanying the product.

- Read these instructions
- Keep these instructions.
- Heed all warnings.
- Follow all instructions.
- Do not use this apparatus near water
- Clean only with dry cloth.
- Do not block any ventilation openings. Install in accordance with the manufacturer’s instructions.
- Do not install near any heat sources such as radiators, heat registers, stoves, or other apparatus (including amplifiers) that produce heat.
- Do not defeat the safety purpose of the polarized or grounding-type plug. A polarized plug has two blades with one wider than other. A grounding-type plug has two blades and a third grounding prong. The wide blade or the third prong is provided for your safety. If the provided plug does not fit into your outlet, consult an electrician for replacement of the obsolete outlet.
- Protect the power cord from being walked on or pinched particularly at plugs, convenience receptacles and the point where they exit from the apparatus.
- Only use attachments/accessories specified by the manufacturer
- Unplug this apparatus during lightning storms or when unused for long periods of time.
- Refer all servicing to qualified service personnel. Servicing is required when the apparatus has been damaged in any way, such as power-supply cord or plug is damaged, liquid has been spilled or objects have fallen into the apparatus, the apparatus has been exposed to rain or moisture, does not operate normally, or has been dropped.

### **WARNING**

TO REDUCE THE RISK OF FIRE OR ELECTRIC – SHOCK, DO NOT EXPOSE THIS APPARATUS TO RAIN OR MOISTURE

### **WARNING**

DO NOT EXPOSE THIS EQUIPMENT TO DRIPPING OR SPLASHING AND ENSURE THAT NO OBJECTS FILLED WITH LIQUIDS ARE PLACED ON THE EQUIPMENT

### **WARNING**

TO COMPLETELY DISCONNECT THIS EQUIPMENT FROM THE AC MAINS, DISCONNECT THE POWER SUPPLY CORD PLUG FROM THE AC RECEPTACLE

### **WARNING**

THE MAINS PLUG OF THE POWER SUPPLY CORD SHALL REMAIN READILY OPERABLE

## INFORMATION TO USERS IN EUROPE

### NOTE

#### CISPR 22 CLASS A DIGITAL DEVICE OR PERIPHERAL

This equipment has been tested and found to comply with the limits for a Class A digital device, pursuant to the European Union EMC directive. These limits are designed to provide reasonable protection against harmful interference when the equipment is operated in a commercial environment. This equipment generates, uses, and can radiate radio frequency energy and, if not installed and used in accordance with the instruction manual, may cause harmful interference to radio communications. Operation of this equipment in a residential area is likely to cause harmful interference in which case the user will be required to correct the interference at his own expense.

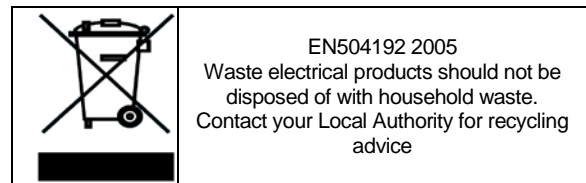
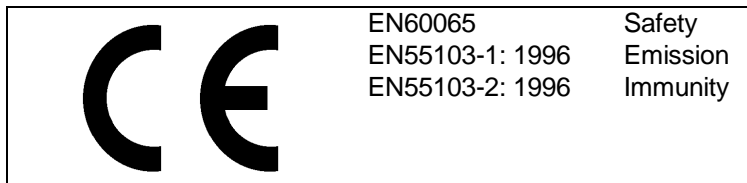

## INFORMATION TO USERS IN THE U.S.A.

### NOTE

#### FCC CLASS A DIGITAL DEVICE OR PERIPHERAL

This equipment has been tested and found to comply with the limits for a Class A digital device, pursuant to Part 15 of the FCC Rules. These limits are designed to provide reasonable protection against harmful interference when the equipment is operated in a commercial environment. This equipment generates, uses, and can radiate radio frequency energy and, if not installed and used in accordance with the instruction manual, may cause harmful interference to radio communications. Operation of this equipment in a residential area is likely to cause harmful interference in which case the user will be required to correct the interference at his own expense.

### WARNING

Changes or Modifications not expressly approved by Evertz Microsystems Ltd. Could void the user's authority to operate the equipment.

Use of unshielded plugs or cables may cause radiation interference. Properly shielded interface cables with the shield connected to the chassis ground of the device must be used.

## TABLE OF CONTENTS

1.	OVERVIEW .....	1
2.	GETTING STARTED .....	5
2.1.	REAR PLATE .....	5
2.2.	ETHERNET CONNECTION .....	7
2.3.	GPIO CONNECTOR .....	8
2.3.1.	INPUTS .....	8
2.3.2.	OUTPUTS .....	9
3.	TECHNICAL SPECIFICATIONS .....	11
3.1.	SERIAL DIGITAL VIDEO INPUT .....	11
3.2.	SERIAL DIGITAL VIDEO OUTPUT .....	11
3.3.	ELECTRICAL .....	12
3.4.	PHYSICAL .....	12
4.	STATUS LEDS .....	13
4.1.	MODULE STATUS LEDS .....	13
5.	VISTALINK® PRO INTERFACE .....	15
5.1.	VIDEO .....	16
5.1.1.	Video Control .....	16
5.1.2.	PGM IN <A,B,C,D> Monitor .....	18
5.1.3.	Video Traps .....	18
5.2.	REFERENCE .....	18
5.2.1.	Reference Control .....	19
5.2.2.	Reference Status .....	19
5.2.3.	Auto Reference Fail-Over .....	20
5.2.4.	VITC Reader .....	20
5.2.5.	Reference Trap Enable .....	20
5.2.6.	Auto Reference Fail-Over Trap Enable .....	21
5.3.	ACS OVERVIEW .....	21
5.3.1.	ACS Control .....	22
5.4.	SLIPLESS OPERATION .....	26
5.4.1.	Slipless Operation Control .....	27
5.4.2.	Additional Video Delay <1-4> .....	31
5.4.3.	Slipless Operation Monitoring .....	31
5.5.	AVM MONITORING OVERVIEW .....	32
5.5.1.	Video Monitoring .....	34
5.5.2.	ANC Monitoring .....	37
5.5.3.	Audio Monitoring .....	40
5.5.4.	Audio Type Monitoring .....	42
5.5.5.	Source ID Monitoring .....	43

- 5.6. ACS DECISION CRITERIA..... 47**
  - 5.6.1. Invalid Video Logic..... 47
  - 5.6.2. Fault Cancellation Mode ..... 47
- 5.7. SD-VBI ..... 50**
  - 5.7.1. SD VITC Configuration..... 50
  - 5.7.2. SD Closed Caption Configuration..... 50
  - 5.7.3. SD Teletext Read Line ..... 51
- 5.8. GPIO ..... 52**
- 5.9. IP..... 55**
  - 5.9.1. Control IP Configuration..... 55
- 5.10. CHANGE PRODUCT ..... 56**
  - 5.10.1. Directly Set ..... 56
  - 5.10.2. Script Set ..... 56
- 5.11. OUTPUT ROUTING ..... 57**
- 5.12. GPI CONTROLLED ROUTING ..... 59**
- 5.13. SYSTEM..... 60**
- 5.14. THUMBNAILS..... 61**
  - 5.14.1. Thumbnails Configuration ..... 61
- 5.15. NTP ..... 62**
- 5.16. REMOTE SYSLOG ..... 62**
- 5.17. PRESETS..... 63**
  - 5.17.1. Preset Control..... 63
  - 5.17.2. User Presets ..... 64
- 5.18. SUB-PRESETS ..... 64**
  - 5.18.1. User Sub-preset Single Load ..... 65
  - 5.18.2. User Sub-preset Multiple Load..... 65
- 6. WEB INTERFACE ..... 67**
- 7. UPGRADE PROCEDURE..... 71**
  - 7.1. VISTALINK® PRO UPGRADE PROCEDURE ..... 71**
  - 7.2. UPGRADE FIRMWARE ..... 73**
    - 7.2.1. Firmware Upgrade Using VistaLINK® PRO ..... 73
    - 7.2.2. Firmware Upgrade using WebEASY®..... 76
  - 7.3. UPGRADE PRODUCT STRING..... 76**
- 8. APPENDIX A ..... 79**
  - 8.1. HARDWARE OPTIONS ..... 79**
  - 8.2. VERSIONS..... 79**

**FIGURES**

Figure 1-1 : 7800R4x8-ACS Block Diagram .....	4
Figure 2-1 : 7800R4x8-ACS/7800R4X8-ACS-BPRP/7800R4X8-ACS-BPRP2 Rear Plates.....	5
Figure 2-2 : GPI Input Circuitry .....	8
Figure 2-3 : GPO Output Circuitry .....	9
Figure 4-1 : 7800R4x8-ACS Status LEDs .....	13
Figure 5-1 : 7800R4x8-ACS in VistaLINK® PRO Hardware Tree.....	15
Figure 5-2 : VistaLINK® PRO - Video Section .....	16
Figure 5-3 : VistaLINK® PRO - Reference Section .....	19
Figure 5-4 : VistaLINK® PRO - ACS Control Section.....	23
Figure 5-5 : VistaLINK® PRO - Slipless Operation Section.....	26
Figure 5-6 : Delay Compensation Case 1 .....	29
Figure 5-7 : Delay Compensation Case 2 .....	29
Figure 5-8 : Connection Between Fault, Trap and ACS.....	33
Figure 5-9 : VistaLINK® PRO - Video Monitoring Section .....	34
Figure 5-10 : VistaLINK® PRO - ANC Monitoring Section.....	37
Figure 5-11 : VistaLINK® PRO - Audio Monitoring Section .....	40
Figure 5-16 : VistaLINK® PRO - Audio Type Monitoring Section .....	42
Figure 5-12 : VistaLINK® PRO - Source ID Monitoring Section .....	44
Figure 5-13 : VistaLINK® PRO - ACS Decision Criteria Section .....	49
Figure 5-14 : VistaLINK® PRO – SD-VBI Section .....	50
Figure 5-15 : VistaLINK® PRO - GPIO Section.....	52
Figure 5-16 : Video / GPO Router Interaction - Select 1.....	53
Figure 5-17 : Video / GPO Router Interaction - Select 2.....	54
Figure 5-18 : VistaLINK® PRO - IP Section .....	55
Figure 5-19 : VistaLINK® PRO - Change Product Section .....	56
Figure 5-20 : VistaLINK® PRO - Output Routing Section.....	57
Figure 5-21 : VistaLINK® PRO - Output Source Change Alarm.....	58
Figure 5-22 : VistaLINK® PRO - GPI Controlled Routing Section .....	59
Figure 5-23 : VistaLINK® PRO - System Section.....	60
Figure 5-24 : VistaLINK® PRO – Thumbnails Section .....	61
Figure 5-33 : VistaLINK® PRO – NTP Section.....	62
Figure 5-34 : VistaLINK® PRO – Remote Syslog Section.....	62
Figure 5-25 : VistaLINK® PRO - Presets Section.....	63
Figure 5-26 : VistaLINK® PRO - Sub-Presets Section .....	64
Figure 6-1 : WebEASY® - Login Menu.....	67
Figure 6-2 : WebEASY® - Frame Controller Menu .....	68
Figure 6-3 : WebEASY® - 7800R4x8-ACS-3G Menu.....	69
Figure 7-1 : VistaLINK® PRO - Upgrade Window .....	71
Figure 7-2 : VistaLINK® PRO - Module Dropdown Menu .....	72
Figure 7-3 : VistaLINK® PRO - Version Information Section .....	72
Figure 7-4 : VistaLINK® PRO - Version information selection .....	73
Figure 7-5 : VistaLINK® PRO - Version Information Window .....	74
Figure 7-6 : VistaLINK® PRO - Upgrade Firmware Window .....	74
Figure 7-7 : WebEASY® - Selecting Upgrade .....	76
Figure 7-8 : WebEASY® - Firmware Upgrade Menu.....	76
Figure 7-9 : VistaLINK® PRO - Opening 7800R4x8-ACS Module Configuration.....	77
Figure 7-10 : VistaLINK® PRO - 7800R4x8-ACS module configuration view .....	77

**TABLES**

Table 2-1 : Color Code Wiring for the Current RJ 45 Standards .....	7
Table 2-2 : GPIO Connector Pin-out.....	8
Table 5-1 : Supported Input Video Standards.....	17
Table 5-2 : Change-Over Modes of Operation.....	24
Table 5-3 : Maximum Supported Delay .....	28
Table 5-4 : Source ID - VANC Packet Payload.....	43
Table 5-5 : GPO Sources .....	53



## REVISION HISTORY

REVISION	DESCRIPTION	DATE
1.0	First Release	Nov 2016
2.0	Full Update	June 2017
2.1	Added Primary PGM Output, Auto Switch Back Delay, Slipless Nominal Video Tolerance, Video Missing Duration/Timeout, Upstream Decoder MBD/VLD Error, Source ID Mismatch, Audio Type Monitoring, NTP and Remote Syslog	June 2019

Information contained in this manual is believed to be accurate and reliable. However, Evertz assumes no responsibility for the use thereof nor for the rights of third parties, which may be affected in any way by the use thereof. Any representations in this document concerning performance of Evertz products are for informational use only and are not warranties of future performance, either expressed or implied. The only warranty offered by Evertz in relation to this product is the Evertz standard limited warranty, stated in the sales contract or order confirmation form.

Although every attempt has been made to accurately describe the features, installation and operation of this product in this manual, no warranty is granted nor liability assumed in relation to any errors or omissions unless specifically undertaken in the Evertz sales contract or order confirmation. Information contained in this manual is periodically updated and changes will be incorporated into subsequent editions. If you encounter an error, please notify Evertz Customer Service department. Evertz reserves the right, without notice or liability, to make changes in equipment design or specifications.

*This page is left intentionally blank*

## 1. OVERVIEW

The protection switch is a critical part of implementing fault tolerance through redundancy and as such is a core function in any broadcast environment. Its role is to choose which redundant upstream path should be used as the system's video source. When done well, the protection switch ensures the integrity of its output video even when faced with a catastrophic error on the primary input. A protection switch is equally suited to protect both the input and the output of a facility. When video sources arrive on multiple redundant and diverse links, a protection switch will choose the best link as the source for the facility. Also, a facility might reduce its exposure to the risk of internal equipment failures by having two redundant processing paths. A protection switch is then utilized to select the best processing path and ensure the integrity of the facility's transmission.

The 7800R4x8-ACS is a protection switching product that performs this task with excellence. It has a number of advanced features that allow it to continuously select the best possible input source for its output. A configurable set of advanced Audio Video Monitoring (AVM) parameters are utilized to determine an input's validity. Then the Advanced Clean Switch uses this information to choose a valid input video source for the output. This selection is done each frame and the Advanced features of the clean switch ensure that a change between input sources is not detectable.

The AVM logic in the 7800R4x8-ACS is powerful and enables the protection switch to avoid passing along a wide variety of errors by monitoring many aspects of the video. These monitoring capabilities include the ability to detect transport data errors, as well as critical content deficiencies. In order to verify the integrity of the physical SDI link, the AVM system includes parameters such as SDI carrier status, Video Standard Detection, and CRC error detection. This level of monitoring provides protection against some errors, but it is unable to detect problems with the content itself. The 7800R4x8-ACS provides a more sophisticated set of video monitoring parameters in order to detect content related errors. These AVM parameters include Frozen Picture detection, Black Picture detection, Picture Level monitoring, Audio Level monitoring as well as Ancillary Data monitoring. Many of these AVM metrics have user-adjustable thresholds and time periods to allow them to be tailored to suit each system's unique requirements.

Traditionally, a protection switch simply monitors its inputs for faults and switches away once a fault has been detected. These protection switches simply *minimize* the number of errors that are allowed through. The 7800R4x8-ACS's delay buffers make it possible to completely *avoid* allowing an error through. The delay for each input is independent, allowing the video content to be temporally aligned before switching. Once aligned, a change in the output video's source will happen without a temporal "slip" in the content, making the switch visually undetectable. Additionally, Evertz SoftSwitch technology ensures "popless" switching of embedded audio, making the switch audibly undetectable. Ancillary data is treated with similar care, ensuring continuity of the data. This attention to detail produces a consistently high quality output video signal even while the Advanced Clean Switch is changing the video's source.

Another benefit of aligning the sources is that it allows for the AVM statuses to be aligned as well. The 7800R4X8-ACS can compare the status of a particular AVM metric in an intelligent manner and this allows it to recognize an error much quicker and more accurately. For example, we traditionally look for

almost a full minute of very quiet audio before we declare an audio stream to be silent. The exceptionally long timeout is required to avoid the many false errors that would be created simply because the content was intentionally quiet. When comparing AVM metrics for equivalent frames, the 7800R4x8-ACS is able to significantly reduce this time period because the real error will become clear when one input goes into silence but the other inputs do not.

In an ideal world, the skew between main and backup inputs would be fixed for a given system. In many of today's systems, however, where main and backup paths could go through many different networks and communication technologies, the skew between signals cannot be assumed to be fixed. Buffer levels in the path will settle out at different levels, a change in the physical satellite will come with a corresponding change in propagation delay, and the exact latency over a WAN cannot be guaranteed. This variation presents a significant challenge when attempting to align multiple inputs transported over different media. Fortunately, the 7800R4x8-ACS offers a number of optional features that reduce the operational complexities involved in correcting for these varying delays. The +TCA option enables the module to use the embedded Time Code information (ATC) to automatically adjust internal delay buffers so that there is no skew between the inputs to the 7800R4x8-ACS's crosspoint. The +SID option enables the module to utilize the information inside the embedded Source ID ANC packet for alignment. When the automatic alignment features are enabled, all input video signals are both synchronized in phase and aligned in time. This is the power of the 7800R4x8-ACS product: it can quickly and automatically adjust to changes in upstream latency to ensure that any switch between redundant inputs is undetectable. The reference time used to align the video signals can be chosen in a number of ways. The user can choose to have it automatically determined, either for the entire product, or independently for each ACS module. Another option is to have the module aligned to an External Reference source. These choices give the product the necessary flexibility to treat each pair separately, automatically align all input video feeds together within a product or even across multiple products in the 7800R4x8-ACS family.

The 7800R4x8-ACS also has a powerful set of 8 GPIOs. They can be used in conjunction with the GPIO router to pass temporally sensitive GPI information across the switch. The variable delays required to temporally align the input video sources make externally passing GPIO signals that are temporally related to a video source across the switch difficult. This GPIO router enables the 7800R4x8-ACS module to take care of generating a temporally aligned GPO signal that can frame accurately control downstream equipment. Additionally, the GPIs can be used to control the 7800R4x8-ACS module by recalling presets or by directly controlling the output video router. The GPOs can be used to report simple status information such as which input is sourcing a particular output or the validity of a particular input.

Advanced Clean Switch technology that combines the power of an Automatic Change Over based on a powerful set of AVM metrics with Automatic Temporal Alignment provides the ultimate in protection for important content. When downtime and errors are costly, the 7800R4x8-ACS ensures maximum uptime and uninterrupted delivery of revenue generating content.

***Features & Benefits***

- Visually and audibly seamless switching between input sources
- Advanced Clean Switch determines validity based on a configurable set of Audio and Video Monitoring metrics.
- Large delay buffers (> 120 frames / input) allow all inputs to be temporally aligned (+DLY option)
- Automatic delay adjustment using embedded Time Code (+TCA option)
- Automatic delay adjustment using embedded Source ID (+SID option)
- External alignment allows temporal alignment across multiple products
- Frame Synchronizers on each input
- Automatic control of the Output Video Router based on the video's validity
- Manual control of the Output Video Router via GPIs, SNMP or the Web GUI.
- Both Single and Dual path configurations are supported allowing for:
  - A single protected output using up to four redundant inputs
  - Two protected outputs each using two inputs
- GPIO Router to simplify forwarding of temporally sensitive GPIO information.
- Optional bypass relay protection: +BPRP provides a single bypass relay, while +BPRP2 provides two bypass relays, ideal for use when the product is to be used in dual 2x1 mode.
- VistaLINK<sup>®</sup> capable for remote monitoring, control and configuration capabilities via SNMP; using VistaLINK<sup>®</sup> PRO, CP-2116E or CP-2232E Control Panels. VistaLINK<sup>®</sup> is available when modules are used with the 7800FR or 7801FR with 7800/7801FC frame controller installed.
- Web GUI for remote monitoring, control and configuration capabilities when modules are used with the 7800FR or 7801FR with 7800/7801Fc frame controller installed
- 16 video outputs using mini DIN 1.0/2.3 connectors (HD BNC connectors with +HDBNC option)
  - 2 independently routable output paths (8 copies of each) come standard
  - 8 independently routable output paths (2 copies of each) (+6OP option)
- Support for SD, HD and 3Gb/s (-3G option) SDI signals

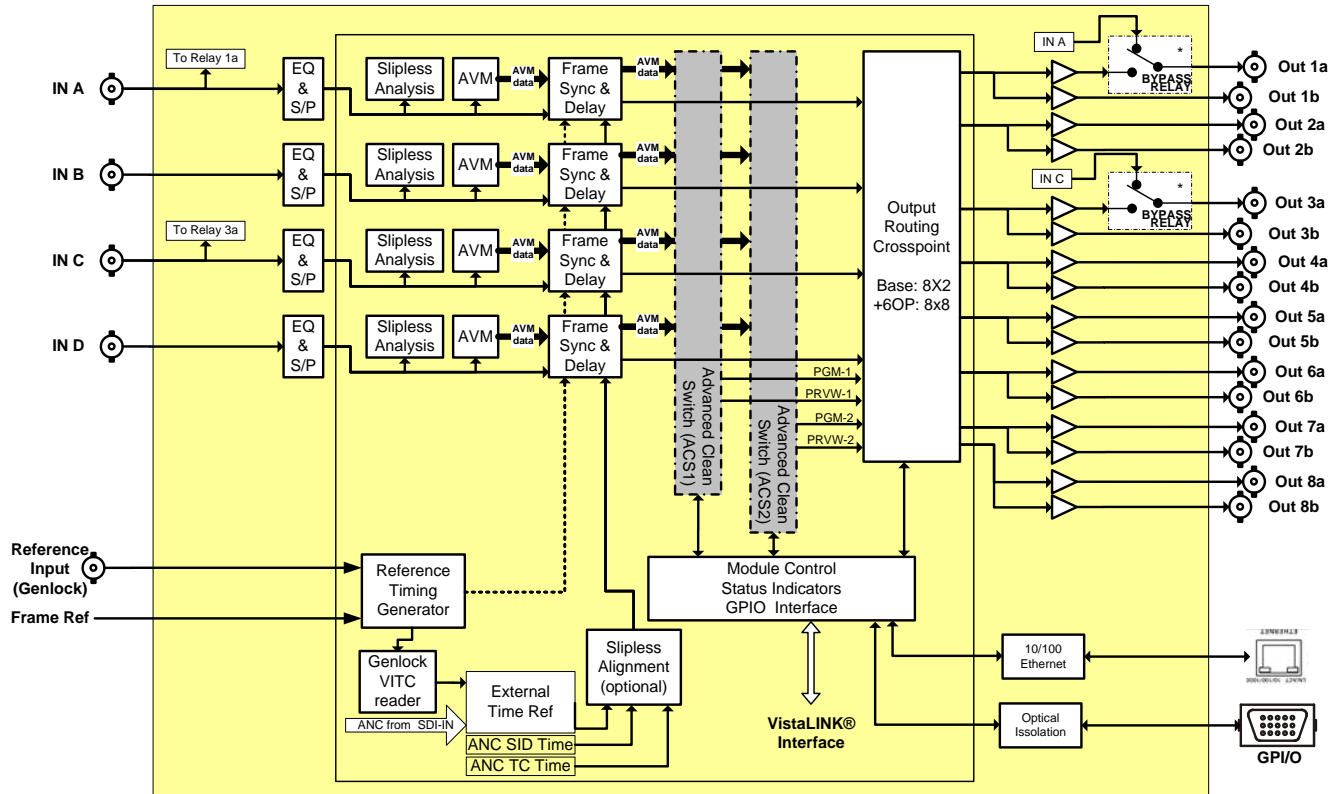

\* Standard connectors are DIN. HD-BNCs may be ordered with the +HDBNC option

**Figure 1-1 : 7800R4x8-ACS Block Diagram**

## 2. GETTING STARTED

The 7800R4x8-ACS series modules come with a companion rear plate and occupy two slots in a 7800FR frame. For information on mounting the rear plate and inserting the module into the frame see section 3 of the 7800FR manual. Refer to Figure 2-1 for 7800R4x8-ACS series rear plate layout.

### 2.1. REAR PLATE

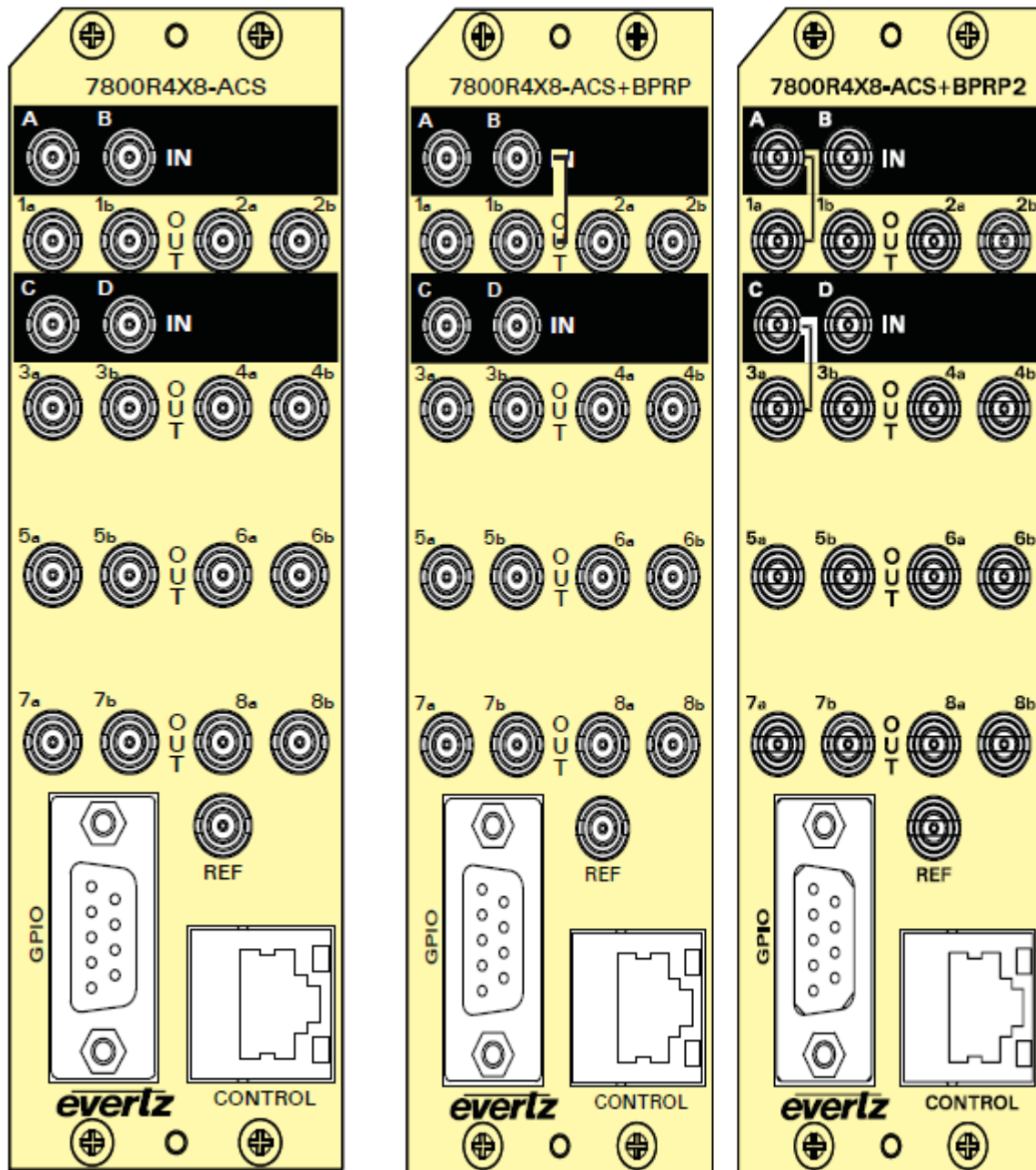

Figure 2-1 : 7800R4x8-ACS/7800R4X8-ACS-BPRP/7800R4X8-ACS-BPRP2 Rear Plates

#### IN (A,B,C,D)

Accepts a 10-bit serial digital video signal (SDI) compatible with SMPTE 259M, SMPTE ST 292-1 and SMPTE ST 424. The module can be set to receive a specific video standard or set to automatically detect the supplied input video standard. See specifications for a complete list of the video formats supported.

#### OUT (1a, 1b ... 8a, 8b)

Each output video signal is a 10-bit serial digital video signal compatible with SMPTE 259M, SMPTE ST 292-1 or SMPTE ST 424. The specific video format is specified by the *Output Video Standard* user control. See the specifications for a list of supported video formats. The specific input video signal routed to each output is governed by the user controls on the *Output Routing* section. The choices are Automatic selection by the Advanced Clean Switch module or Manual selection using the GPIs or the *Output Video Routing* control. See section 5.11 for more details.

#### REF

Accepts a Bi-Level or Tri-Level analog video reference. The reference format is auto-detected by the module. See specifications for a list of supported formats. Reference may also be supplied via the 7700FR-G and 7800FR FRAME REFERENCE inputs. There is no requirement that the reference's video format match the output video's format. However, the reference frame or field rate must match the output video's frame or field rate. The 7800R4x8-ACS's reference source is governed by the user controls on the *Reference* section in VLPro. The user can choose to force the reference to a particular source, or take advantage of the Auto Reference Fail-Over logic which enables the module to automatically select the highest priority reference source available. See section 5.2 for more details.



## 2.2. ETHERNET CONNECTION

All 7800R4x8-ACS series modules are designed to use either 10Base-T (10 Mbps) or 100Base-TX (100 Mbps) also known as *Fast Ethernet*, twisted pair Ethernet cabling systems. When connecting for 10Base-T systems, category 3, 4, or 5 UTP cable as well as EIA/TIA – 568-100Ω STP cable may be used. When connecting for 100Base-TX systems, category 5 UTP cable is required. Make the network connection by plugging one end of a “straight through” cable into the RJ-45 receptacle of the 7800R4x8-ACS modules and the other end into a port of the supporting hub.

Straight-through RJ-45 cables can be purchased or can be constructed using the pin out information in Table 2-2. A color code-wiring table is provided in Table 2-1 for the current RJ-45 standards (AT&T 258A or EIA/TIA 258B color coding shown). Also, refer to the notes following the table for additional wiring guide information.

Pin #	Signal	EIA/TIA 568A	AT&T 258A or EIA/TIA 568B	10BaseT or 100BaseT
1	Transmit +	White/Green	White/Orange	X
2	Transmit –	Green/White or White	Orange/White or Orange	X
3	Receive +	White/Orange	White/Green	X
4	N/A	Blue/White or Blue	Blue/White or Blue	Not used (required)
5	N/A	White/Blue	White/Blue	Not used (required)
6	Receive –	Orange/White or Orange	Green/White or Green	X
7	N/A	White/Brown	White/Brown	Not used (required)
8	N/A	Brown/White or Brown	Brown/White or Brown	Not used (required)

Pin  
1

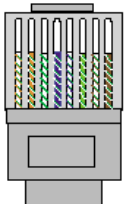

**Table 2-1 : Color Code Wiring for the Current RJ 45 Standards**

Note the following cabling information for this wiring guide:

- Only two pairs of wires are used in the 8-pin RJ 45 connector to carry Ethernet signals.
- Even though pins 4, 5, 7 and 8 are not used, it is mandatory that they be present in the cable.
- 10BaseT and 100BaseT use the same pins; a crossover cable made for one will work with the other.
- Pairs may be solid colors and not have a stripe.
- Category 5 cables must use Category 5 rated connectors.

The maximum cable run between the 7800R4x8-ACS series modules and the supporting hub is 300 ft (90 m).

### 2.3. GPIO CONNECTOR

There are 8 General Purpose Inputs/Outputs (GPIOs) on the 7800R4x8-ACS series modules. Each GPIO may be configured to be an input or configured to be an output. These GPIOs are accessible using a 9-pin DB connector on the rear plate. Table 2-2 shows the DB-9 pin assignment.

DB-9 Pin	Name	Description
1	GPIO1	General Purpose Input / Output 1
2	GPIO2	General Purpose Input / Output 2
3	GPIO3	General Purpose Input / Output 3
4	GPIO4	General Purpose Input / Output 4
5	GPIO5	General Purpose Input / Output 5
6	GPIO6	General Purpose Input / Output 6
7	GPIO7	General Purpose Input / Output 7
8	GPIO8	General Purpose Input / Output 8
9	GND	Ground
Shell	GND	Ground

**Table 2-2 : GPIO Connector Pin-out**

#### 2.3.1. INPUTS

Figure 2-2 shows the circuit interface that applies, when a particular GPIO is configured to be a GPI.

The GPI inputs are actually sensitive to current but it is often more convenient to think of them as being voltage sensitive and *active low* with an internal pull up to +5.0 Volts. To make a GPI *active*, the external circuit must draw current from the GPI pin by connecting it through a low resistance path to ground (pin 9 of the DB9 connector). To make a GPI *inactive*, the external circuit must draw less than 100  $\mu$ A of current. This GPI interface allows the user to easily connect a mechanical button or switch while still supporting active control through the use of relays or directly with an open collector interface.

**Note:** Unused (and unconnected) GPIs will not be activated.

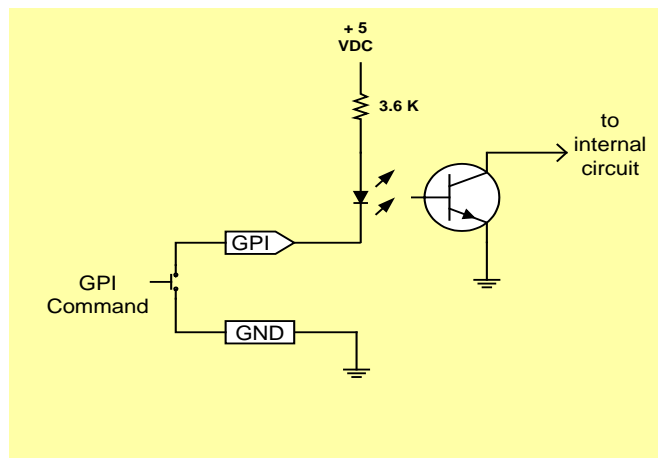

**Figure 2-2 : GPI Input Circuitry**

### 2.3.2. OUTPUTS

Figure 2-3 shows the circuit interface that applies, when a particular GPIO is configured to be a GPO.

The GPO output produces a voltage level. It can sink current, but current must not be drawn from the GPO pin. The GPO is active low with an internal pull up to +5.0 Volts. When the GPO is *active*, the voltage at the pin is low (0 Volts DC) and the GPO can be used to sink up to 10mA of current. When the GPO is *inactive*, the voltage at the pin is high (+5.0 Volts DC) and must not be relied upon as a current source. **Drawing more than 100 $\mu$ A from a GPO will cause the corresponding GPI to activate. If this happens, the GPI will appear inactive from a voltage point of view. However, this parasitic current draw will cause the module to see a GPI status of active.**

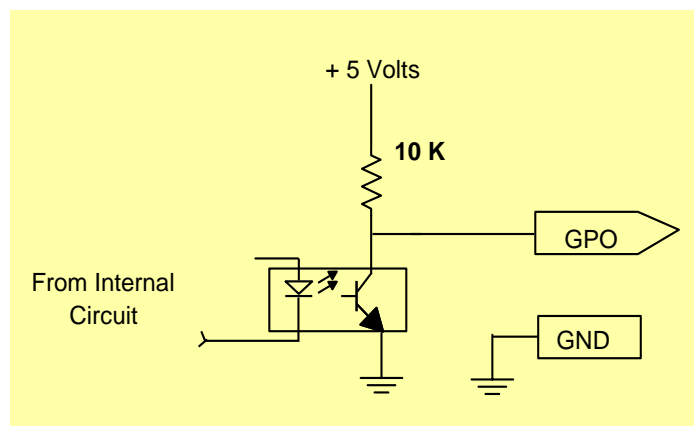

Figure 2-3 : GPO Output Circuitry

*This page is left intentionally blank*

### 3. TECHNICAL SPECIFICATIONS

#### 3.1. SERIAL DIGITAL VIDEO INPUT

<b>Standard</b>	270 Mb/s SMPTE 259M 10 bit 4:2:2 (525i/59.94, 625/50) 1.485 Gb/s SMPTE ST 292-1 10 bit 4:2:2 : (1080i/60, 1080i/50, 1080p/30, 1080p/30sF, 1080p/25, 1080p/25sF, 1080p/24, 1080p/24sF, 720p/60, 720p/50, 720p/30, 720p/25, 2048x1080p/30, 2048x1080p/30sF, 2048x1080p/25, 2048x1080p/25sF, 2048x1080p/24, 2048x1080p/24sF)* 2.970 Gb/s SMPTE ST 425-1 Level A and Level B - 10 bit 4:2:2 (1080p/60, 1080p/50, 2048x1080p/60, 2048x1080p/50)* *Includes the 1/1.001 rates where applicable
<b>Number of Inputs</b>	4
<b>Connector</b>	DIN 1.0/ 2.3 or HD-BNC with the +HDBNC option
<b>Signal Level</b>	800 mV nominal
<b>Input Equalization</b>	Automatic to 85m @ 2.970 Gb/s with Belden 1694 or equivalent Automatic to 130m @ 1.485 Gb/s With Belden 1694 or equivalent Automatic to 300m @ 270 Mb/s with Belden 1694 or equivalent
<b>Return Loss</b>	>15 dB to 1.5 GHz >10 dB to 3.0 GHz

#### 3.2. SERIAL DIGITAL VIDEO OUTPUT

<b>Standard</b>	270 Mb/s SMPTE 259M 10 bit 4:2:2 (525i/59.94, 625/50) 1.485 Gb/s SMPTE ST 292-1 10 bit 4:2:2 : (1080i/60, 1080i/50, 1080p/30, 1080p/30sF, 1080p/25, 1080p/25sF, 1080p/24, 1080p/24sF, 720p/60, 720p/50, 720p/30, 720p/25, 2048x1080p/30, 2048x1080p/30sF, 2048x1080p/25, 2048x1080p/25sF, 2048x1080p/24, 2048x1080p/24sF)* 2.970 Gb/s SMPTE ST 425-1 Level A and Level B - 10 bit 4:2:2 (1080p/60, 1080p/50, 2048x1080p/60, 2048x1080p/50)* *Includes the 1/1.001 rates where applicable
<b>Number of Outputs</b>	16
<b>Connector</b>	DIN 1.0/ 2.3 or HD-BNC with the +HDBNC option
<b>Signal Level</b>	800mV Nominal
<b>SD Rise/Fall Times</b>	740ps nominal
<b>HD Rise/Fall Times</b>	200ps nominal
<b>Return Loss</b>	>15 dB to 1.5 GHz >10 dB to 3.0 GHz

## 7800R4x8-ACS Series

HD/3G 4x8 Protection Switch with Advanced Clean Switch Processing



### 3.3. ELECTRICAL

<b>Voltage</b>	+12VDC
<b>Power</b>	<30 Watts
<b>EMI/RFI</b>	Complies with FCC regulations for Class A devices. Complies with EU EMC directive

### 3.4. PHYSICAL

#### Number of slots

<b>7800FR Frame</b>	2
<b>7801FR Frame</b>	2
<b>7700FR Frame</b>	3 (slot blocker must be installed for proper operation)

## 4. STATUS LEDS

### 4.1. MODULE STATUS LEDS

Figure 4-1 illustrates the status LED functional assignments for the 7800R4x8-ACS series modules. The 7800R4x8-ACS utilizes both GREEN and RED LEDs. The GREEN LEDs report status information, while the RED LEDs report fault conditions.

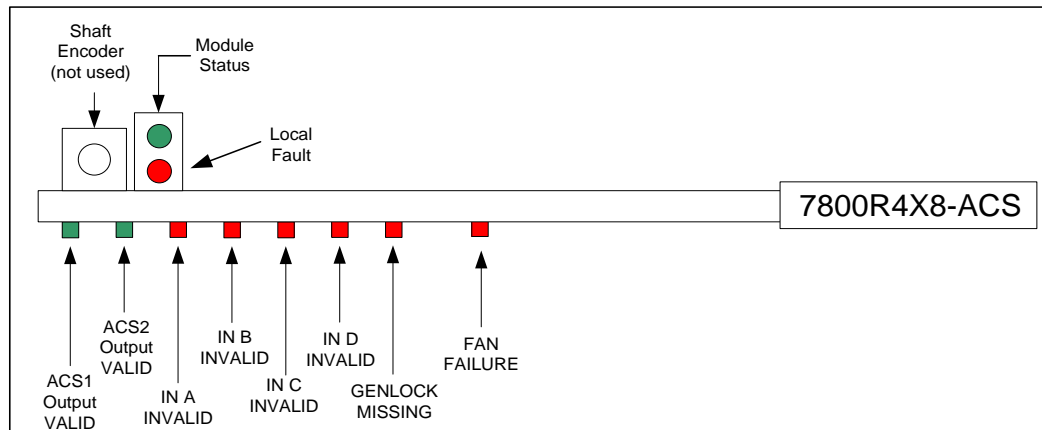

**Figure 4-1 : 7800R4x8-ACS Status LEDS**

**MODULE STATUS:** The module’s overall status is indicated by a pair of mutually exclusive Green (OK) and Red (Fault) LEDs.

**MODULE OK:** LED will be GREEN when the 7800R4x8-ACS module is operating properly and has valid signals on all of the essential inputs. Otherwise the LED will be OFF because the status is not okay.

**LOCAL FAULT:** LED will be RED when the module is not okay and therefore has a fault. The LED will be OFF when it is operating properly. A fault could be caused by:

- A hardware problem such as a fan failure or a blown power fuse
- A major firmware problem such as a problem during boot
- Missing one of the inputs essential for operation

**Essential Inputs:**

1. A valid reference is always considered *essential*. See section 5.2 for details on how to select the reference source.
2. The input video sources that are *required* depend on the operating mode.
  - i. When using the ACS logic to choose a valid output, all inputs connected to a virtual ACS Input (see section 5.3) are *required* and must be “Valid”, as defined by the ACS Decision criteria (see section 5.6).
  - ii. When all of the ACS Input controls are set to “None”, the *required* video input sources are defined by what is currently routed to an output. See sections 5.11 and section 5.12 for information about manually controlling the output video router.

**ACS1 Output VALID:** LED will be GREEN when the video selected as the PGM output for the 1<sup>st</sup> ACS module is valid. LED will be RED otherwise.

**ACS2 Output VALID:** LED will be GREEN when the video selected as the PGM output for the 2<sup>nd</sup> ACS module is valid. LED will be RED otherwise.

**IN A INVALID:** LED will be RED when IN A is not valid according to the ACS decision criteria when IN A is connected to a virtual ACS Input (see section 5.3). When IN A is not connected to an ACS input the LED will be RED when IN A is NOT detected as being present. The LED will be GREEN for valid input video signals.

**IN B INVALID:** LED will be RED when IN B is not valid according to the ACS decision criteria when IN B is connected to a virtual ACS Input (see section 5.3). When IN B is not connected to an ACS input the LED will be RED when IN B is NOT detected as being present. The LED will be GREEN for valid input video signals.

**IN C INVALID:** LED will be RED when IN C is not valid according to the ACS decision criteria when IN C is connected to a virtual ACS Input (see section 5.3). When IN C is not connected to an ACS input the LED will be RED when IN C is NOT detected as being present. The LED will be GREEN for valid input video signals.

**IN D INVALID:** LED will be RED when IN D is not valid according to the ACS decision criteria when IN D is connected to a virtual ACS Input (see section 5.3). When IN D is not connected to an ACS input the LED will be RED when IN D is NOT detected as being present. The LED will be GREEN for valid input video signals.

**GENLOCK MISSING:** LED will be RED when a supported Genlock signal cannot be detected on the selected Genlock input (*CARD REF/FRAME REF 1/ FRAME REF 2*) The LED will be GREEN for valid Genlock signals.

**FAN FAILURE:** LED will be RED when either cooling fan fails. LED will be GREEN when both fans are operational.



## 5. VISTALINK® PRO INTERFACE

The 7800R4x8-ACS series products are controllable using VistaLINK® PRO. VistaLINK® PRO operates using Ethernet and SNMP control protocols. The 7800R4x8-ACS series modules DO NOT HAVE card edge control support nor direct SNMP agent support. As a result, a 7800FC, 7801FC or 7700FC module must be installed in all frames that house 7800R4x8-ACS series modules in-order to configure the modules.

Within VistaLINK® PRO, the 7800R4x8-ACS series modules have a set of system configuration controls. The system configuration controls can be accessed by *right-clicking* on the module in the VistaLINK® PRO hardware tree, and selecting *view configuration*. Figure 5-1 illustrates how a 7800R4x8-ACS module will appear in the VistaLINK® PRO hardware tree.

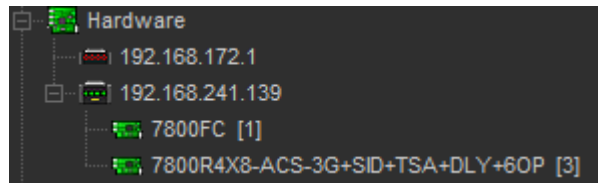

Figure 5-1 : 7800R4x8-ACS in VistaLINK® PRO Hardware Tree



**NOTE:** When using VistaLINK® PRO it is important to ensure that the most recent 7800R4x8-ACS series “.JAR” control file is installed. See Section 7.1 for details on how to upgrade the 7800R4x8-ACS series VistaLINK® PRO JAR files.

## 5.1. VIDEO

The Video section contains all controls related to core video configuration as well as basic monitoring information regarding the input video to the 7800R4x8-ACS module. Figure 5-2 illustrates the layout of the controls in the VistaLINK® PRO configuration view.

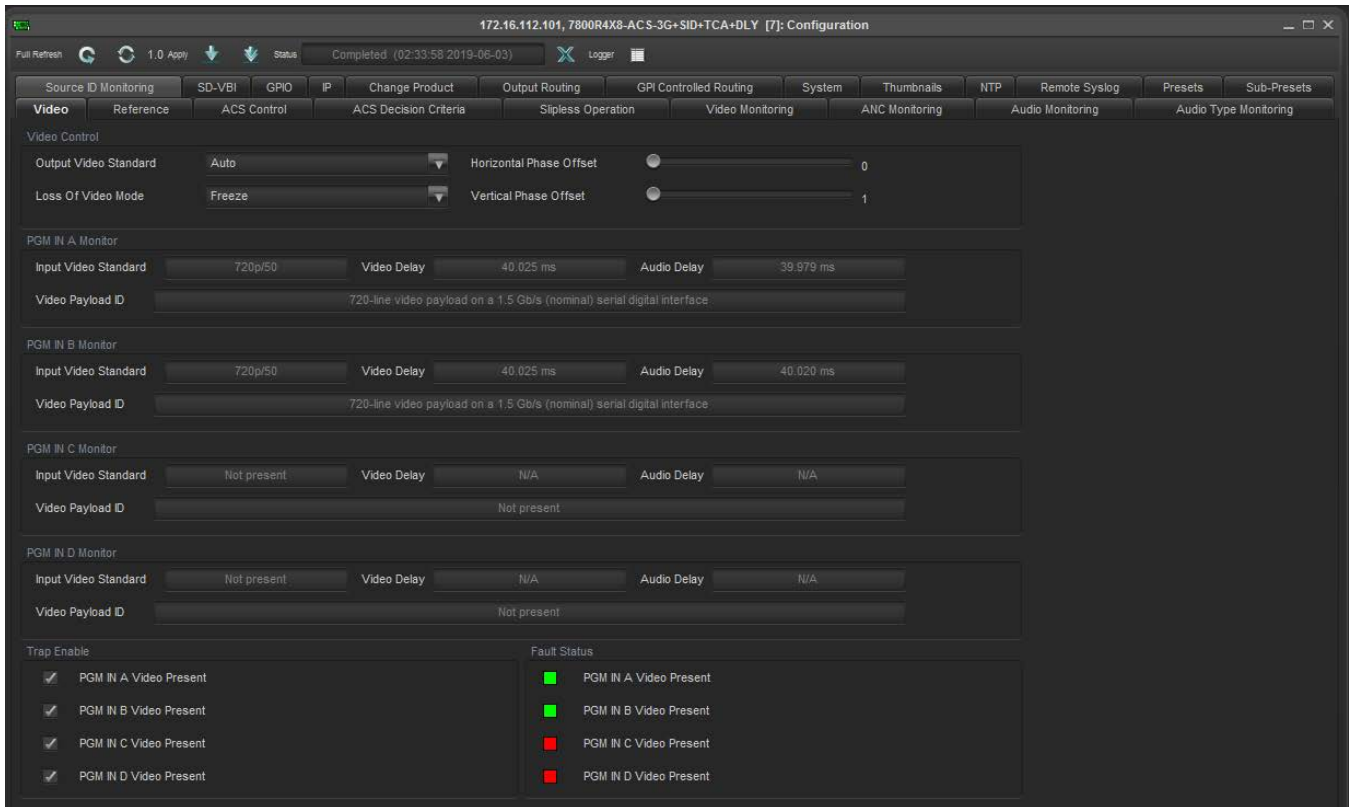

**Figure 5-2 : VistaLINK® PRO - Video Section**

### 5.1.1. Video Control

**Output Video Standard:** This control sets the output video standard of the module.

‘Auto’ mode dynamically detects the input video standard, and configures the 7800R4x8-ACS Series’ output video standard accordingly. Otherwise, when set to a specific video standard, the 7800R4x8-ACS Series’ will output the selected video standard and will ignore all inputs that do not match this video standard.



**NOTE:** ‘Auto’ mode is not recommended when using the 7800R4X8-ACS to protect the downstream video from errors because it will cause an output video standard change if the input video standard changed in error.

Whenever possible, it is highly recommended to set the Output Video Standard control to the specific video standard being used. Doing so will ensure a valid and stable output video signal.

Interlaced video rates are listed in fields per second. Progressive video rates are listed in frames per second. Table 5-1 lists all supported input video standards.

525i/59.94	1080p/23.98
625i/50	720p/60
1080i/59.94	720p/30
720p/59.94	720p/29.97
1080i/50	720p/25
720p/50	2048x1080p/30sF
1080p/59.94 (425-1 Level A) [-3G option]	2048x1080p/30
1080p/59.94 (425-1 Level B-DL) [-3G option]	2048x1080p/29.97sF
1080p/50 (425-1 Level A) [-3G option]	2048x1080p/29.97
1080p/50 (425-1 Level B-DL) [-3G option]	2048x1080p/25sF
1080p/60 (425-1 Level A) [-3G option]	2048x1080p/25
1080p/60 (425-1 Level B-DL) [-3G option]	2048x1080p/24sF
1080i/60	2048x1080p/24
1080p/30sF	2048x1080p/23.98sF
1080p/30	2048x1080p/23.98
1080p/29.97sF	2048x1080p/60 (425M level A) [-3G option]
1080p/29.97	2048x1080p/60 (425M level B) [-3G option]
1080p/25sF	2048x1080p/59.94 (425M level A) [-3G option]
1080p/25	2048x1080p/59.94 (425M level B) [-3G option]
1080p/24sF	2048x1080p/50 (425M level A) [-3G option]
1080p/24	2048x1080p/50 (425M level B) [-3G option]
1080p/23.98sF	

**Table 5-1 : Supported Input Video Standards**

**Loss of Video Mode:** Each input has its own independent frame buffer and this control determines how that buffer's output will behave when its input video is lost. The output video will only be affected if the lost input is used as the output's source. Options include freezing on the last good frame of input video, or forcing the video to a black or blue image.

**Horizontal Phase Offset:** This control allows the user to set the horizontal timing of all the output video signals with respect to the reference input specified by the *Output Video Reference* status. Setting *H Phase Offset = 0* maintains the horizontal timing alignment of the output video with respect to the reference input. Increasing the value will delay the output video in one-sample increments of the output video standard. In order to advance the horizontal timing of the output video with respect to the reference, set the control to its maximum value minus the number of samples that you wish to advance the output video with respect to reference.

**Vertical Phase Offset:** This control sets the vertical timing of all the output video signals with respect to the reference input specified by the *Output Video Reference* status. Setting *V Phase Offset = 0* maintains the vertical timing alignment of the output video with respect to the reference. Increasing the value of *V Phase Offset* will delay the output video in one-line increments of the output video standard. In order to advance the vertical timing of the output video with respect to the reference, set the control to its maximum value minus the number of lines that you wish to advance the output video with respect to reference.

### 5.1.2. PGM IN <A,B,C,D> Monitor

**Input Video Standard:** This field displays the detected input video standard of the input being monitored. If the module is unable to detect a valid input standard, it will report *Not present*.

**Video Delay:** This field displays the amount of video delay (latency) between the input video signal and the output video signal of the module in milliseconds (ms).

**Audio Delay:** This field displays the amount of audio delay (latency) between the input embedded audio signal and the output embedded audio signal of the module.

**Video Payload ID:** This field reports the detected video payload ID on the incoming video. The information is displayed according to SMPTE 352 descriptions.

### 5.1.3. Video Traps

To enable/disable a specific fault trap, check/uncheck the corresponding checkbox.

**PGM IN <A,B,C,D> Video Present:** This trap will trigger when the respective Input Video is no longer present.

## 5.2. REFERENCE

The reference control section contains all controls that configure the operation of the reference (genlock) processing.

The video reference signal can be sourced from either the module's REF input connection on the rear plate, or either of the FRAME REF inputs on the 7800FR or 7700FR-G frames.

The 7800R4x8-ACS supports locking to both bi-level and tri-level reference signals.

The auto-reference fail-over feature is used to automatically lock to secondary (*lower priority*) reference input signals when the main (*priority 1*) reference drops out. This improves robustness of the system, and ensures the output timing remains locked to the desired reference timing in the event of failure on the primary reference input.

Figure 5-3 illustrates the layout of the reference controls in the VistaLINK<sup>®</sup> PRO module configuration view.

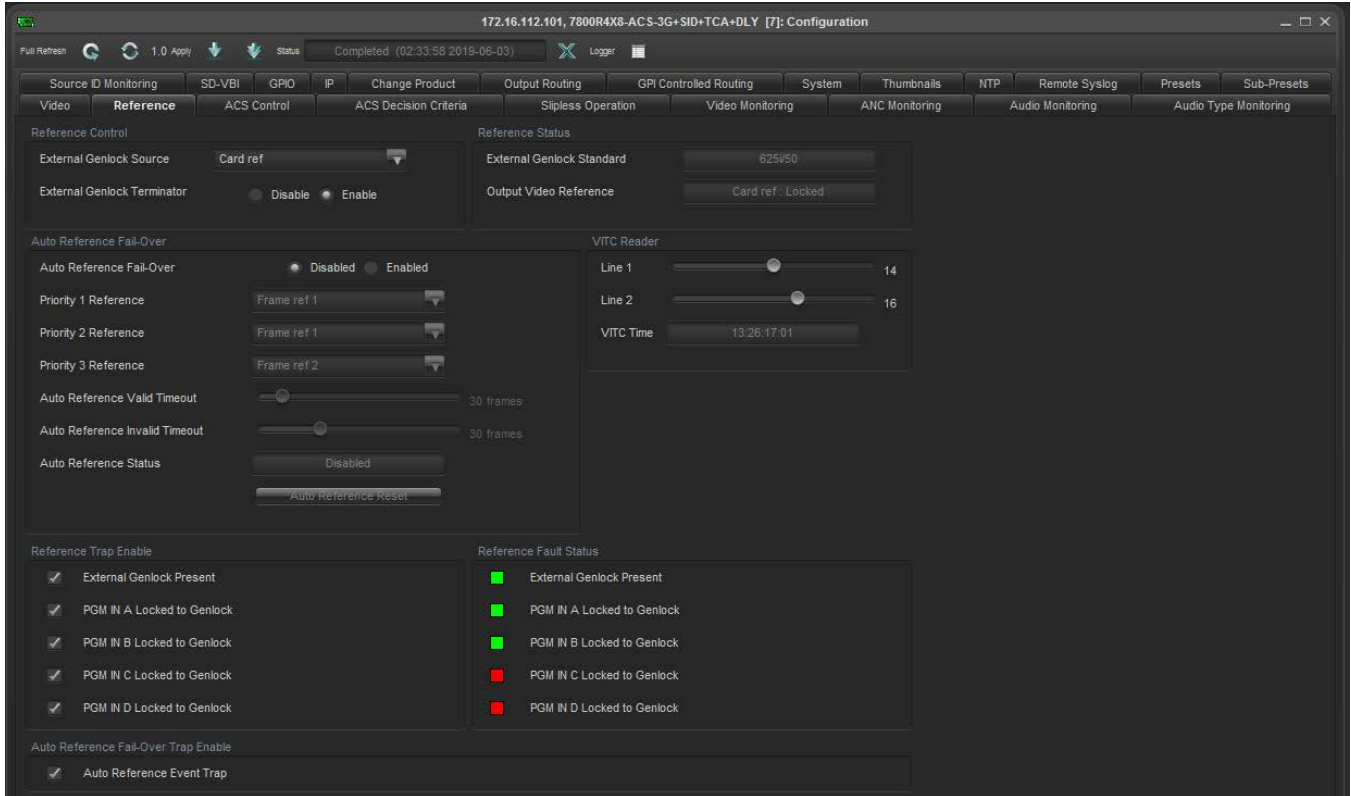

Figure 5-3 : VistaLINK® PRO - Reference Section

### 5.2.1. Reference Control

**External Genlock Source:** This control is used to configure which physical reference input is selected as the Genlock input signal. When **Card Ref** is selected, the module will be sourced by the external reference signal applied to the REF input on the 7800R4x8-ACS’s rear panel. When **Frame ref 1** is selected, the module will lock to the external reference applied to the 7800 frame **REF 1** input. When **Frame ref 2** is selected, the module will be sourced by the external reference applied to the 7800 frame **REF 2** input.

**External Genlock Terminator:** This control specifies if a 75 ohm termination is applied to the input reference signal.

### 5.2.2. Reference Status

**External Genlock Standard:** *External Genlock Standard* reports the video standard of the detected reference signal. If a signal has been detected, but the module cannot determine the video standard, it will report *Unknown*. If no reference signal is present on the selected reference input, it will report *Not present*.

**Output Video Reference:** *Output Video Reference* reports the current reference as well as its status. It will report “None” when a valid genlock source is not present. When a valid reference source is present it will report the source (Card Ref, Frame Ref 1, or Frame Ref 2) as well as the current output status with respect to this reference. It will report Locked when the output video is phase and frequency locked to the specified reference. It will report Locking when it has found a valid reference

but has not yet achieved lock. It will report *Unlocked* when the reference source is invalid and it is unable to lock.



**NOTE:** The 7800R4x8-ACS product cannot lock to input video.

### 5.2.3. Auto Reference Fail-Over

**Auto Reference Fail-Over:** This control allows the user to enable the automatic reference fail-over system. The auto reference fail-over system will automatically select the highest priority reference input signal that is present and valid.

**Priority 1 Reference:** This control sets the main reference. If present and valid, this reference will be used as the source to the module.

**Priority 2 Reference:** This control sets the second reference. It will be selected in the case of a failure or loss of the priority 1 reference signal.

**Priority 3 Reference:** This control sets the third reference. It will be selected in the case of a failure or loss of the priority 1 and 2 reference signals.

**Auto Reference Valid Timeout:** This control allows the user to select the amount of time (*in frames*) a reference has to be valid before it is considered to be present and can be locked to. That value range is between 0 frames and 300 frames.

**Auto Reference Invalid Timeout:** This control sets the amount of time (*in frames*) a reference has to be missing before it is considered to be absent. The value range is between 0 frames and 100 frames.

**Auto Reference Status:** This reports the current source of reference for the module. If the module is currently locked to a reference signal, it will report the source of the reference signal as *Card ref*, *Frame ref 1*, or *Frame ref 2*. If the video path is currently free-running, it will report *None*.

**Auto Reference Reset:** This button allows the user to reset the auto reference fail-over selection algorithm. It causes all reference sources to be re-scanned according to priority.

### 5.2.4. VITC Reader

**Line 1-2:** This control specifies the line numbers from which VITC Time Code will be extracted in the external reference signal. The module supports reading two lines of redundant VITC. This provides some noise immunity and allows a valid read to occur even if one of the VITC waveforms is corrupted by a noise event.

**VITC Time:** This control reports the VITC time value that was extracted from external reference signal.

### 5.2.5. Reference Trap Enable

To enable/disable a specific fault trap, check/uncheck the corresponding checkbox.

**External Genlock Present:** This trap will trigger when the External Genlock is no longer present.

**PGM IN A,B,C and D Locked to Genlock:** This trap will trigger when the respective video input is no longer locked to Genlock. In this case the term “locked to Genlock” refers to the input video signal having a constant phase with respect to the currently selected reference source. It can be used to detect a problem with reference in a device upstream.

### 5.2.6. Auto Reference Fail-Over Trap Enable

To enable/disable a specific fault trap, check/uncheck the corresponding checkbox.

**Auto Reference Event Trap:** This event trap will trigger whenever there is a change of reference event in the auto reference fail-over algorithm. The event trap includes binding information of the *Auto Reference Status* parameter. This is an event trap, and thus has no specific fault condition. Rather, it provides status information to the alarm server whenever a trigger event has occurred.

## 5.3. ACS OVERVIEW

The 7800R4x8-ACS series modules support advanced audio, ancillary data, and video monitoring (AVM). The module performs simultaneous real time monitoring of all video input signals and supports VistaLINK<sup>®</sup> PRO status reporting and SNMP trap alarm facilities to provide notification of any observed input video signal error condition.

The internal AVM processor also provides real time, frame accurate input signal monitoring status information to the Advanced Clean Switch (ACS) processor. This AVM status information is used in conjunction with the ACS decision criteria to perform automatic clean switching of the input video signals when operating in one of the automatic change over processing modes (Auto Switch Back, Auto Switch and Auto Non-Revertive).

Most of the AVM parameters are tuned using three basic user controls: *threshold*, *duration*, and *timeout*. The *threshold* controls sensitivity of the parameter and ultimately determines when a *Potential Error* is detected in a particular frame. An input frame is marked as having a particular *Potential Error* simply because the associated AVM parameter’s value has moved outside of the acceptable range (as defined by the *threshold* user control). This does not necessarily indicate that a real problem exists. For example, it is expected that the audio level will fall below the *Audio Silence Threshold* for short periods of time and those quiet portions of the audio should not cause the input video to have a *Fault* until they have persisted for a long period of time. The *duration* user control is used to determine if there is sufficient evidence that the *Potential Error* is a real problem and that the input should be marked as having a *Fault*. There is also a similar mechanism for clearing the *Fault* condition. In many cases it is desirable for the input to be without a *Potential Error* for a certain amount of time before the system begins to trust that the error which caused the *Fault* has actually been corrected. The *timeout* user control allows the user to adjust the period free from *Potential Errors* that is required before a fault is cleared. These three controls give the user the ability to tune the AVM parameters so that they respond appropriately.

The 7800R4x8-ACS module can be configured to automatically switch away from any input that is considered *Invalid*. The requirements for an input video source are different for each application. For example, some applications may require 4 groups of audio to be present, while others may only require a single group of audio. For this reason the ACS decision criteria must be used to select which *Faults* are significant enough to cause the input video to be considered *Invalid*. These controls allow the user to determine which particular AVM FAULTS will trigger an automatic clean switch.

Additionally, the [+DLY] option enables the sizable delay buffers associated with each input that can be used to temporally frame-align the input signals before the Advanced Clean Switch. This ensures that switching between input signals is not only clean, but slipless. This can be done manually or automatically with the appropriate product option (Source ID [+SID] or Time Code [+TCA]). When configured in one of the Automatic Slipless modes, the module will utilize metadata within the input video signals to automatically temporally frame-align the input signals and ensure clean & slipless switching between inputs, making switches between two redundant inputs completely undetectable on the program output. This feature can be valuable when the redundant input signals arrive through diverse transmission paths with different delays.

Furthermore, once the duration time period has been satisfied, it is assumed that the frames during the duration period also have the *Fault*. The input is considered to have the *Fault* at the beginning of the duration time period and not after the period ends. This allows a *Fault* to be completely avoided if the inputs are delayed more than the duration time period.

### 5.3.1. ACS Control

The ACS (*Advanced Clean Switch*) control section contains controls that configure the operation of the clean switch processor.

There are two virtual ACS Processors in the 7800R4x8-ACS product. Each ACS processor considers up to four input video signals and selects an input video source for the program (ACS#-PGM) and the preview (ACS#-PRVW) video sources. The video selected as ACS1-PGM, ACS1-PRVW, ACS2-PGM and ACS2-PRVW can then be routed to any physical output by using the *Output Routing* controls. The operation of the clean switch processor is dependent on the user configuration of the controls on both the ACS Control & ACS Decision Criteria tabs within the VistaLINK<sup>®</sup> PRO configuration interface.

The 7800R4x8-ACS is designed to cleanly switch between the input video signals by exactly phase-aligning the inputs with respect to the provided reference signal. Simultaneously with the video switch, the processor employs audio cross fade processing for soft audio switching.

Figure 5-4 illustrates the layout of the ACS controls in the VistaLINK<sup>®</sup> PRO module configuration view.



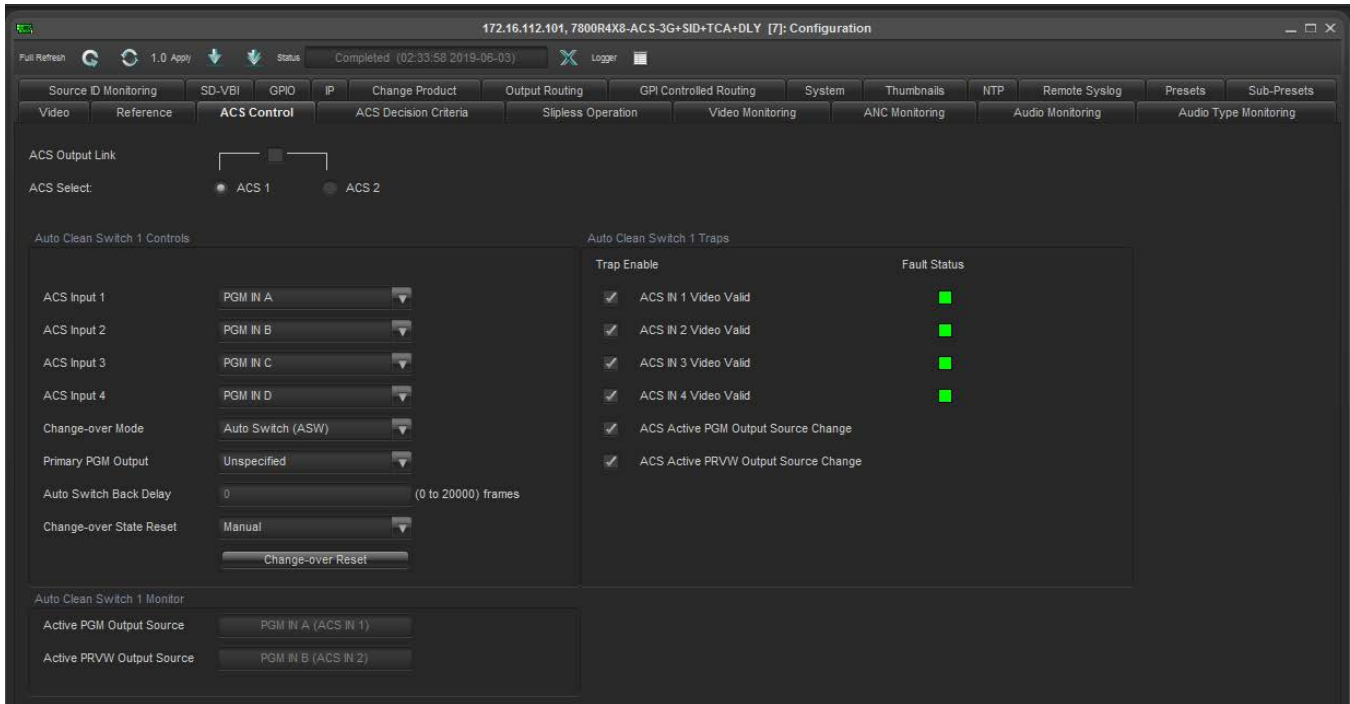

Figure 5-4 : VistaLINK® PRO - ACS Control Section

### 5.3.1.1. Advanced Clean Switch Controls

**ACS Input<1-4>:** This control specifies which physical video input is connected to each of the virtual ACS inputs. The ACS Processor will choose one of these inputs as the source for the ACS#-PGM output and another for the ACS#-PRVW output.



**NOTE:** ACS Input 1 is given the highest priority while ACS Input 4 is given the lowest priority.

**ACS Output Link:** It may be desirable for multiple ACS Processors to be linked together so that they always select the same Virtual Input for their Program output. One example of this would be if the module is being used to clean switch between two multi link inputs (Quad Link, or Dual Link) and it is desirable to select a consistent set of inputs. In the case of Dual Link SDI the ACS Processors need to work on a pair of inputs. It might not be acceptable to select the main input for Link A and the backup input for Link B.

The ACS Processors can be “linked” together to ensure that a consistent set of inputs is selected. When two ACS Processors are linked, the Virtual Input Number chosen for ACS1-PGM will also be chosen for ACS2-PGM. This means that the Inputs for both ACS Processors must be considered VALID for a virtual input to be considered VALID.

**Change-Over Mode:** This control specifies the mode of operation of the Clean Switch Processor. The mode choices are *Auto Switch Back*, *Auto Switch*, or *Auto Non-Revertive*. See Table 5-2 for a description of each option.

<p><b>Auto Switch Back (ASB)</b></p>	<p>Selects source of the virtual program output (ACS#-PGM) using the following rules:</p> <ul style="list-style-type: none"> <li>• Always use the highest priority input (ACS Input 1 is preferred over other inputs) that is considered to be VALID by the ACS decision criteria.</li> <li>• Only switch to a new input if it is considered to be VALID by the ACS decision criteria.</li> <li>• Switch to a higher priority input even if the currently selected input is considered VALID by the ACS decision criteria.</li> </ul>
<p><b>Auto Switch (ASW)</b></p>	<p>Selects source of the virtual program output (ACS#-PGM) using the following rules:</p> <ul style="list-style-type: none"> <li>• When a switch occurs, use the highest priority input (ACS Input 1 is preferred over other inputs) that is considered to be VALID by the ACS decision criteria.</li> <li>• Only switch to an input that is determined to be VALID by the ACS decision criteria when the current active input is determined to be INVALID.</li> <li>• Never switch away from a source that is determined to be VALID by the ACS decision criteria.</li> <li>• The selection process will be restarted with the highest priority input when a Change-Over State Reset occurs.</li> </ul>
<p><b>Auto Non-Revertive (ANR)</b></p>	<p>Selects source of the virtual program output (ACS#-PGM) using the following rules:</p> <ul style="list-style-type: none"> <li>• Begin by selecting the highest priority input (ACS Input 1 is preferred to other inputs) that is considered to be VALID by the ACS decision criteria.</li> <li>• When the current active input is determined to be INVALID, switch to the next lower priority input that is determined to be VALID by the ACS decision criteria.</li> <li>• Never switch to an input with a Higher Priority than the current active input. Once the lowest priority input (ACS Input 4) has been chosen no other automatic switching will be performed.</li> <li>• The selection process will be restarted with the highest priority input when a Change-Over State Reset occurs.</li> </ul>

**Table 5-2 : Change-Over Modes of Operation**

**Primary PGM Output:** Sets the Physical Output that is connected to the primary downstream Program path. When specified, the ACS Processor’s choice for PGM will follow the Source used for this Physical Output when it has been overridden by the user (See section 5.11 or section 5.12 for more details). This causes the ACS Processor’s Program Choice to stay consistent with the source that is actually being used in situations where the user has forced a particular input.

**A real world example:**

It is often desirable to force the program chain to a particular source while maintenance is taking place. In this example there are two inputs (PGM IN A and PGM IN B) connected to the first virtual ACS Processor and the physical output OUTPUT 1 is connected to the downstream encoder for distribution.

We will begin by discussing how the system behaves when Primary PGM Output is set to *Unspecified* (the default value). Normally *ACS1-PGM* is chosen as the Source Selection for the physical output OUTPUT 1. When maintenance is required on the PGM IN A path the Source Selection is changed from *ACS1-PGM* to *PGM IN B*. This forces the program chain to be sourced by PGM IN B. The virtual ACS Processor continues to select the “best” source for ACS1-PGM and may choose PGM IN A for a significant period of time during the maintenance period. This mismatch between what is actually On-Air (PGM IN B in this case) and the ACS Processor’s choice can cause the 7800R4X8-ACS module to make the wrong decision in things like Temporal Alignment. It can also create unexpected behaviour when the user switches back to “auto” mode. When the maintenance is complete, the Output Routing is changed back to *ACS1-PGM* and the selected source may unexpectedly flip back to PGM IN A. When the Change-Over Mode is set to *ASW* the ACS Processor should only switch when the current source becomes INVALID.

However, if the Primary PGM Output is set to *OUTPUT 1* then PGM IN B will be chosen by the virtual ACS Processor during maintenance. This ensures that the Slipless Operation controller will never make large instantaneous adjustments to the delay of PGM IN B during the maintenance period. It also improves the behaviour when going back to “auto” mode with the Change-Over Mode set to *ASW*. In this case OUTPUT 1 will continue to be sourced by PGM IN B until PGM IN B becomes INVALID.

**Auto Switch back Delay:** Sets the number of consecutive video frames that are NOT considered Invalid before the Clean Switch Processor will switch back to an Input Source when in Auto Switch Back Mode. This control sets a global hysteresis that is independent of the hysteresis inherent in each of the AVM metrics.

**Change-Over State Reset:** There are several situations where it is necessary to force the ACS Processor to reconsider all of its inputs. An example of this is when the Change-Over Mode is set to *Auto Non-Revertive*. In this case the user must intervene in order for the system to revert back to the primary input. The Change-Over State Reset control selects how this reset is accomplished. The choices are as follows:

**Manual:** Activate the Change-Over Reset with the Change-Over Reset Button via an SNMP set.

**GPI <1-8>:** Activate the Change-Over Reset when the specified GPI is activated.

**Change-Over Reset Button:** When the Change-Over State Reset control is set to **Manual**, this button will cause the ACS Processor to restart the selection algorithm and reconsider the highest priority input.

### 5.3.1.2. Advanced Clean Switch Monitor

These fields display the output status of the Virtual Advanced Clean Switch Processor.

**Active PGM Output Source:** This field reports which input is currently selected as program video (ACS#-PGM) by the Virtual Advanced Clean Switch Processor. If enabled, a corresponding event trap (ACS Active PGM Output Source Change) can be sent to the alarm server whenever the value of this status changes.

**Active PRVW Output Source:** This field reports which input is currently selected as preview video (ACS#-PRVW) by the Advanced Virtual Clean Switch Processor. The preview is chosen as the next best input video that would be chosen as the program video source if the input selected as the

program source became invalid. If enabled, a corresponding event trap (ACS Active PRVW Output Source Change) can be sent to the alarm server whenever the value of this status changes.

**5.3.1.3. Advanced Clean Switch Trap Enable**

To enable/disable a specific fault trap, check/uncheck the corresponding checkbox.

**ACS IN <1-4> Video Valid:** Triggers a FAULT trap when the corresponding input video signal is considered to be *INVALID* based on the ACS decision criteria.

**ACS Active PGM Output Source Change:** This event trap will trigger whenever there is a change in the source of the ACS program output. The event trap includes binding information containing the new value of the *Active PGM Output Source* parameter. This is an event trap, and thus has no specific fault condition. Rather, it provides status information to the alarm server whenever a trigger event has occurred.

**ACS Active PRVW Output Source Change:** This event trap will trigger whenever there is a change in the source of the ACS preview output. The event trap includes binding information containing the new value of the *Active PRVW Output Source* parameter. This is an event trap, and thus has no specific fault condition. Rather, it provides status information to the alarm server whenever a trigger event has occurred.

**5.4. SLIPLESS OPERATION**

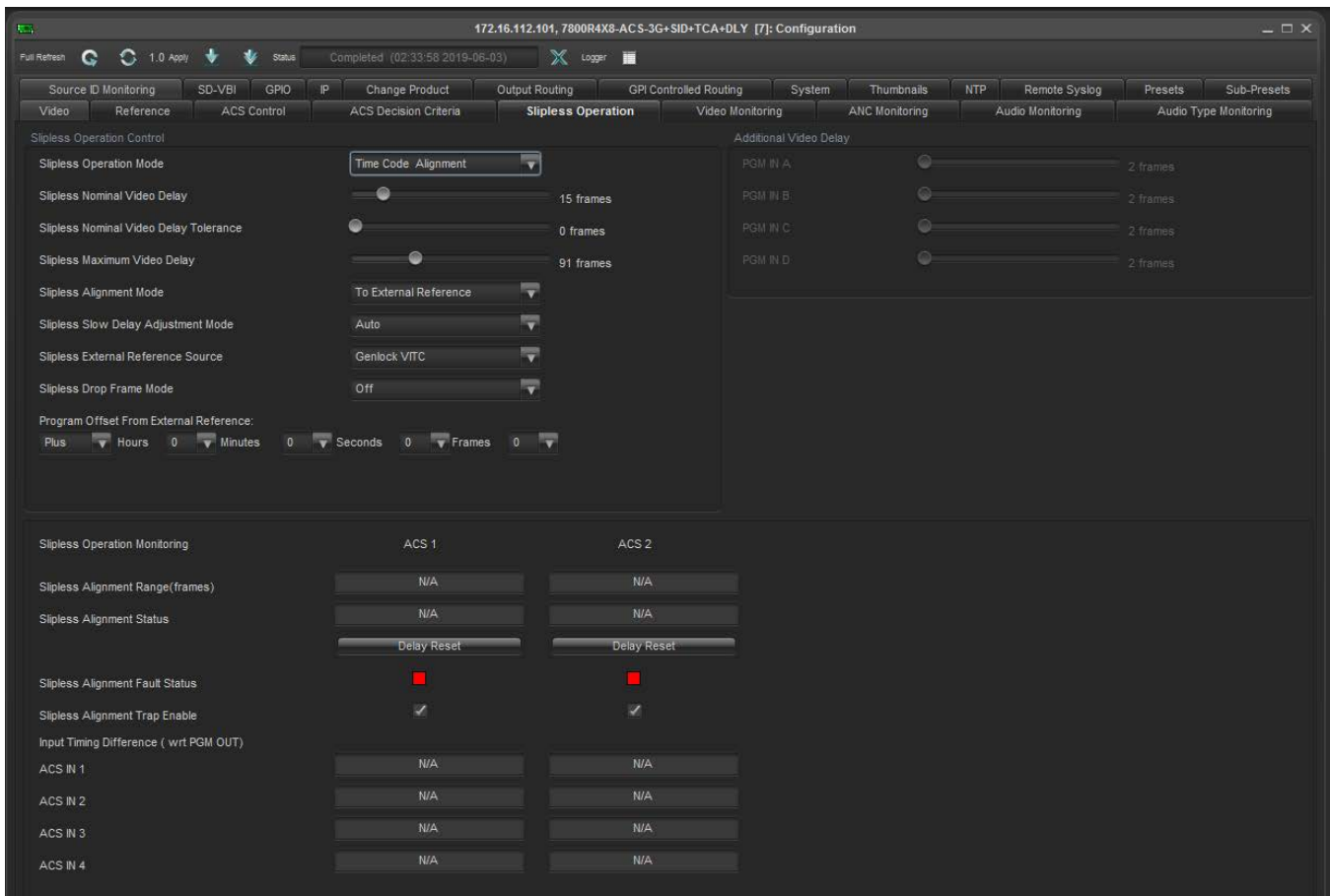

**Figure 5-5 : VistaLINK® PRO - Slipless Operation Section**

### 5.4.1. Slipless Operation Control

It is important that redundancy is added by using two diverse distribution paths for a signal. Different signal paths and equipment decreases the likelihood that both paths will experience a problem at the same time. For example, multiple redundant links that are both transmitted down the same cable do not protect the system against a cable being cut. Given the need for diversity, these paths may have very different latencies and in the worst case each link's latency might change each time it is established. This nondeterministic latency creates several challenges for a system designer. The first is that the two video streams will not be phase aligned when they arrive at their destination. The second is that the latency difference between the two links could create a significant temporal shift between the two video streams. The 7800R4x8-ACS module resolves the first problem with a Frame Sync on each input to ensure that all input video paths are phase aligned before the internal crosspoint switch. This ensures that every change between inputs will be "clean" and that the output video timing will not be disturbed. This "clean" switch is not enough to address the potential temporal shift and a switch will create a "slip" by either skipping or repeating content. The Slipless Operation section is intended to address this challenge.

When the [+DLY] option is included, the 7800R4x8-ACS has the ability to independently adjust the delay of each channel to compensate for different upstream path delays. Once this delay has been adjusted, all of the inputs will be both phase aligned and temporally frame aligned at the input to the internal crosspoint switch. A change between inputs will be "clean" and slipless, making it visually and audibly undetectable.

The per channel delay can be adjusted manually or automatically using information from the Source ID ANC Packet (+SID option) or the Time Code ANC Packet (+TCA option). This is a powerful feature of the 7800R4x8-ACS product family and significantly reduces the system design challenges inherent in selecting the best video stream from multiple diverse and redundant paths. The AVM monitoring assists the operator in choosing the "best" option and when a switch is necessary the slipless nature of this product allows it to happen without impacting the program video output.

**Slipless Operation Mode:** This control selects the method used to adjust the input video delay to produce a Slipless switch between the inputs. The options are:

- **Disable:** This setting will cause the internal frame delays for all input video paths to be equal and set to the minimum of 2 frames.
- **Manual:** This setting will enable manual control of each path's video delay using the *Additional Video Delay* controls.
- **Source ID Alignment:** This enables Automatic Temporal Alignment of all input video paths connected to the ACS module. The alignment algorithm will use the TIME field inside the Source ID ANC Packet as its time reference for temporal alignment.



**NOTE:** The "DID" used for Source ID is selected in the Source ID monitoring section. The last SID tag is always used for alignment. See section 5.5.5.1.

- **Time Code Alignment:** This enables Automatic Temporal Alignment of all input video paths connected to the ACS module. The alignment algorithm will use the ANC Time Code packet (VITC or LTC) as its time reference for temporal alignment.

**Slipless Nominal Video Delay(frames):** This control sets the target minimum delay of the module. When Automatic Temporal Alignment is enabled the module begins with both video paths being delayed by the nominal delay. It then analyzes the alignment reference and, if necessary, will add more delay to the path which arrived earlier in order to temporally align all the video paths connected to

the ACS module. The value range is between 2 frames and the value of the Slipless Maximum Video Delay control.

**Slipless Nominal Video Delay Tolerance (frames):** This control sets the difference between the module’s minimum delay and the Slipless Nominal Video Delay control that is acceptable. There are situations where the minimum delay is not equal to nominal delay after temporal alignment has been achieved. This is caused by the strong desire to avoid adjusting the delay of the Program Outputs. In these situation, the system would normally go into Slow Adjustment Mode to bring the video delays back into conformance with the user settings. This tolerance is provided to allow the user to adjust how different from Nominal the Minimum Delay can be without invoking Slow Adjustment Mode. The default value is 0 and this ensures that the minimum delay is driven to be exactly equal to Nominal Delay.

**Slipless Maximum Video Delay (frames):** This control sets the maximum allowable delay of the module when Automatic Temporal Alignment is enabled. This limits the amount of delay that can be applied when trying to temporally align the input video signals. The minimum value is 3 and the maximum value varies with video standard. The maximum value for each supported video raster size is outlined in Table 5-3.

Raster Size	Maximum Supported Delay
1080 x 2048	122 Frames
1080 x 1920	122 Frames
720 x1280	284 Frames
487 x 720 (525i)	314 Frames
576 x 720 (625i)	314 Frames

**Table 5-3 : Maximum Supported Delay**

The Maximum Video Delay must be greater than the Nominal Video Delay.

**A few notes about delay:**

The values set for Nominal Video Delay and Maximum Video Delay will determine how misaligned the input video signals can be while ensuring the module can immediately perform clean and slipless switches when one of the automatic temporal alignment modes are enabled. Larger values of Nominal Video Delay will allow temporal alignment for larger upstream channel delay increases, but will increase the minimum delay through the module. Larger values of Maximum Video Delay will allow temporal alignment for larger upstream channel delay decreases, but will open the door to much larger potential system delays. These values should be carefully selected in order to balance minimum system delay requirements with the need for the module to temporally align the input video signals to ensure clean & slipless switching.

When an input currently being delayed by the Nominal Delay is lost and reacquired with a larger external path delay, temporal alignment is possible by either decreasing the new input’s internal delay OR by increasing the delay of the video path currently routed to the Program Outputs. Since our goal is to leave the program output undisturbed we highly favor decreasing the path delay on the newly acquired input. This results in a delay less than Nominal Delay. When Nominal Delay is set too low, it may not be possible to decrease the delay of the reacquired video path enough and a switch between the two inputs would no longer be “slipless”.

An example may assist in understanding the tradeoffs.

Under ideal conditions both upstream transmission path delays are equal and the slipless operation control logic will delay both paths by the Nominal Delay. The main input has been chosen as the program output and both paths are aligned, allowing for a clean and slipless switch. See Figure 5-6.

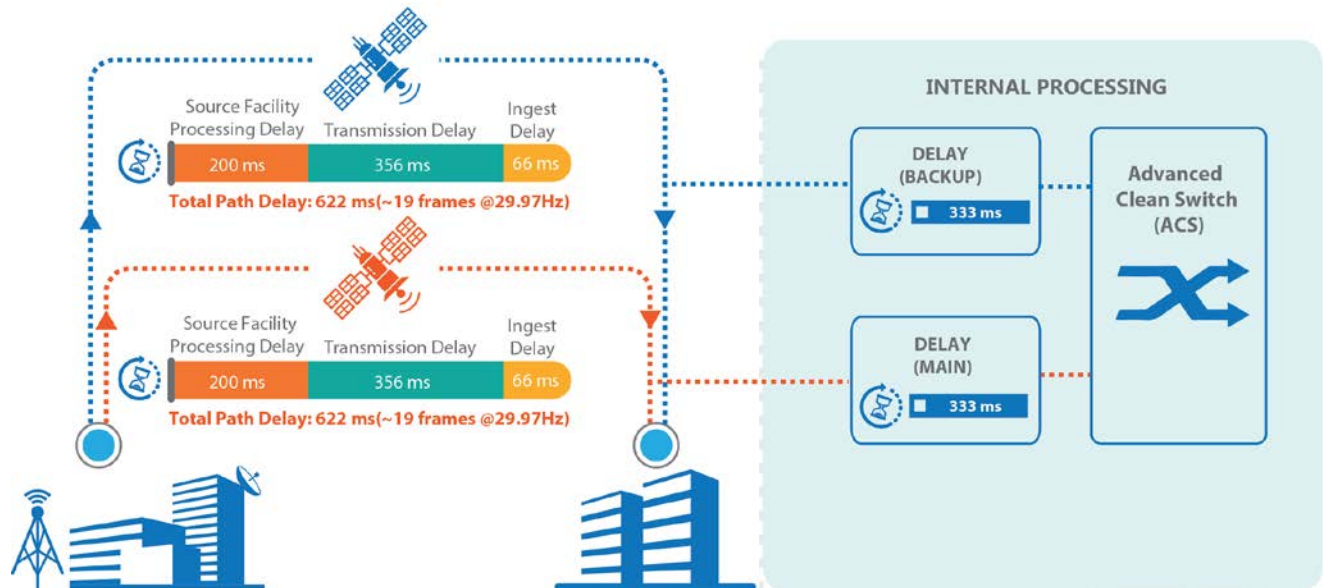

Figure 5-6 : Delay Compensation Case 1

At this point an error occurs causing the backup transmission path to drop. When it is reacquired, the transmission path delay is about 5 frames more than the main input. See Figure 5-7.

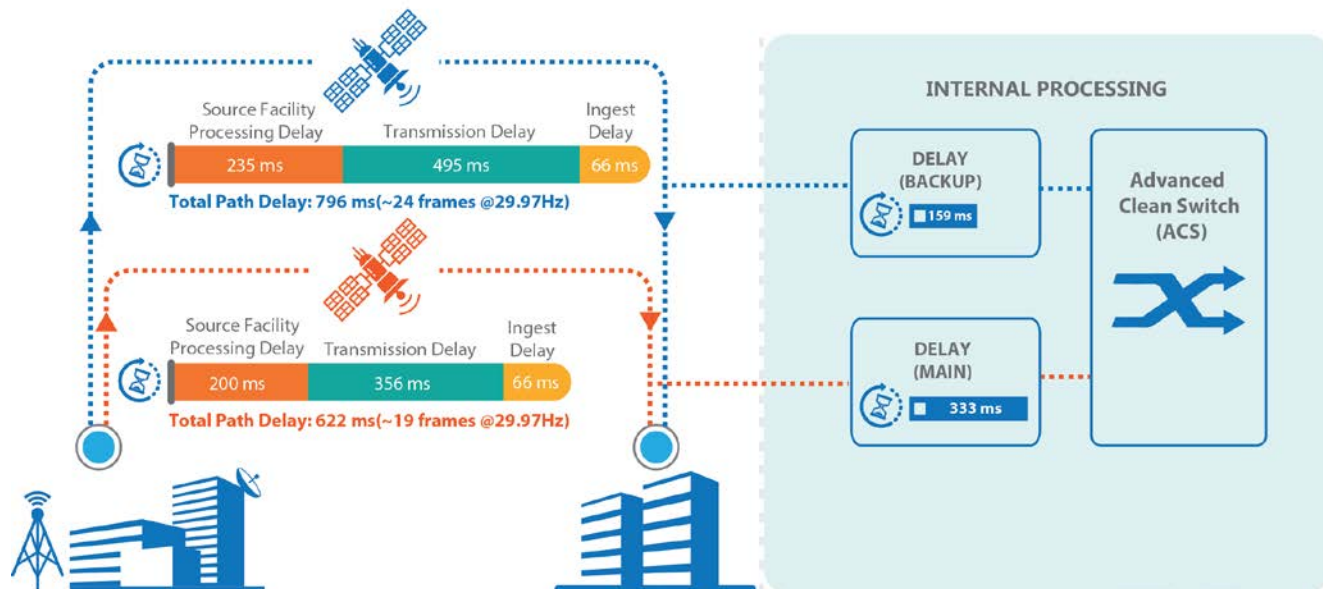

Figure 5-7 : Delay Compensation Case 2

The Slipless Operation controller must delay the *main* input by 5 more frames than the *backup* input in order to achieve alignment. At startup, this new environment would have caused the module to delay the *Backup* input by Nominal Delay and the *Main* input by Nominal Delay + 5 frames. However,

this would cause a change to the delay of the input currently routed to the Program output. That delay choice would result in a content slip on the Program output and we are attempting to avoid any adjustment that affects the Program Output. So, the control logic will prefer to choose a backup delay that is 5 frames (167 ms) less than the *Main* input's current delay. Since the *Main* input is being delayed by Nominal Delay, this will result in the *Backup* input being delayed 5 frames (167 ms) less than Nominal Delay. This would not be possible if the Nominal Delay was set to a value of 3 frames (100 ms) but it would be possible if it was set to a value of 10 frames (333 ms). As can be seen, it is important to consider the range of possible delays for each of the redundant paths when setting the Nominal Delay.

**NOTE:** During normal operation, the 7800R4x8-ACS module will not adjust the delay of the video path currently being routed to the Program Outputs. This goal results in the possibility that the minimum delay for a video path will be less than the nominal delay for a period of time.



When the module is operating with a path delay less than nominal delay, it will slowly add delay to all input video paths (including the one sourcing the Program Outputs) until the minimum path delay has increased to the nominal video delay and the inputs are temporally aligned. The rate at which frames are added or repeated is controlled by the Slipless Slow Adjustment Mode control.

**Slipless Alignment Mode:** The Slipless Alignment Mode determines how the Alignment Algorithm measures temporal alignment and can function in one of three modes. The Alignment Algorithm can be configured to automatically determine an Output Time Reference independently for each ACS Processor. A second option would be for an Output Time Reference to be automatically selected for the entire module. A third option would be to use an Externally provided Reference as the Output Time Reference for the entire module.

The first two choices allow the module to choose a set of delays that temporally align a set of inputs using Nominal Delay and Maximum Delay as its guide. The last option selects a set of delays that will cause all of the outputs to be temporally aligned to particular Time Reference.

The choices are:

**To External Reference:** External Reference is different than the next two choices. Instead of choosing a delay based on the value of Nominal Delay, the Alignment Algorithm attempts to delay each input so that all of the outputs are temporally aligned to the external Time Reference. This can be used to align the output of multiple 7800R4X8-ACS modules, which is a useful feature when attempting to temporally align more video feeds than are supported by a single module. This option could also be used to ensure that a transmission path latency is constant.

**Across Single ACS:** This should be chosen when each ACS Processor is operating on a completely independent set of video feeds. The main and redundant inputs must be temporally aligned to allow for a slipless switch, but there is no requirement to temporally align all of the PGM outputs.

**Across All ACS:** This should be chosen when the video flowing through all of the ACS Processors is related. This is important for situations where each ACS Processor is protecting a different camera feed. In this situation each ACS#-PGM output will be a particular camera and



these camera feeds must be temporally aligned in order to remove the slip when changing cameras angles.

**Slipless Slow Delay Adjustment Mode:** The Alignment Algorithm attempts to avoid making delay adjustments to the input currently selected as one of the ACS#-PGM outputs. However, there are situations where this cannot be avoided. In this case, the Alignment Algorithm will go into “slow adjustment mode”. When operating in this mode it will slowly adjust the delay by a single frame at a time. This control selects how frequently the delay can be adjusted.

- Auto**            The PGM delay will be adjusted so that the audio SRCs are continually slewing the audio delay.
- Slow**            The PGM delay will be adjusted by one frame every 10 minutes.
- Medium**        The PGM delay will be adjusted by one frame every 2 minutes.
- Fast**            The PGM delay will be adjusted by one frame every 5 seconds.

**Slipless External Reference Source:** When the Slipless Alignment Mode is set to “To External Reference”, this control allows selection of the source of the external time reference. The options are the Time Code value in the VITC signal on external genlock or the ANC Timecode value embedded on one of the inputs.

**Slipless Drop Frame Mode:** This control is used to specify if the time value included in the Source ID or Time Code packet is drop frame.

**Program Offset From External Reference:** These controls allow the user to specify a fixed offset from the external time source to use for alignment.

#### 5.4.2. Additional Video Delay <1-4>

When *Slipless Operation Mode* is set to manual, the *Additional Video Delay* controls are used to adjust the delay of the individual input video paths. The delay is in addition to the delay required to Frame Sync the input. This gives the user precise control over how much delay is added to each video path. The value range is between 2 frames and the module’s maximum supported delay for the current raster size. The maximum value for each supported video raster size is outlined in Table 5-3.

#### 5.4.3. Slipless Operation Monitoring

**Slipless Alignment Range (frames):** This status field is intended to help the user understand the effect of Nominal Delay and Maximum Video Delay on the ability for the module to achieve temporal alignment. It will report the supported external path delays relative to the external path delay of the input currently selected as the program output. For example, when Nominal Delay is 10 frames and Maximum Video Delay is 50 frames the status will be “less: 40 more: 7” if the input currently selected as the program output is being delayed by nominal delay. This means that the current settings will support external path delays that are 7 frames more and 40 frames less than the external path delay of the input that is currently selected as the program output. Turn to page 28 for more details.

**Slipless Alignment Status:** This field reports the current alignment status of the video inputs. “N/A” will be reported to indicate that we are unable to determine if the inputs are aligned when the delays are being controlled manually. When the delays are being controlled automatically it will report “Aligned” when alignment has been achieved. It will report “Aligned(Slow Adj)” when alignment has been achieved but the system is slowly adjusting the delay. It will report “Out-Of-Range” when the module

does not have access to enough delay to align the inputs due to the settings chosen for Nominal Video Delay and Maximum Video Delay. It will report “Unaligned” when the relationship between the inputs is known because of the presence of Source ID or Time Code but the delay has not yet been adjusted.

**Sliplless Delay Reset Button:** The 7800R4x8-ACS’s reluctance to adjust the delay of the source being routed to the Program Output causes a problem during initial system configuration. It is very likely that the system will enter Slow Adjustment mode during this time period because the delays of the system are typically changing. The Delay Reset Button can be used to override the slow adjustment process to allow all delays to be adjusted so that they snap into alignment.



**NOTE:** Pressing the Sliplless Delay Reset Button may cause a temporal slip in the content of the output video.

**Sliplless Alignment Trap:** The Sliplless Alignment will be in Fault whenever the *Sliplless Alignment Status* does not indicate “Aligned”. The Fault status is reported by this box, where red means that the inputs are not aligned and green means that they are aligned. An SNMP trap can be generated on this fault condition by checking the check-box to enable the trap.

**Input Timing Difference (wrt PGM OUT)**

These fields report the difference between the inputs in terms of the time reference (either Source ID or Time Code). The value is the difference between the respective input and the input currently selected as the Program Output. This allows the user to determine the temporal offset being measured by the sliplless operation control logic. There is a value for each logical ACS Input.

**Note:** The mapping between the logical ACS Inputs and the Physical Inputs is determined by the ACS Input 1 to ACS Input 4 controls.

**5.5. AVM MONITORING OVERVIEW**

Part of the power of the 7800R4x8-ACS product is the ability to automatically select the best input to route to the program output. This is only achievable by the powerful set of Audio, ANC and Video Monitoring metrics that are available in the product. The 7800R4x8-ACS independently monitors each input against a set of metrics. When the metrics indicate an error, the applicable Fault is assigned to that input video Frame. As described in Figure 5-8, this Fault can then be used to drive the SNMP trap system and / or be used by the ACS logic to determine if the input video is valid.

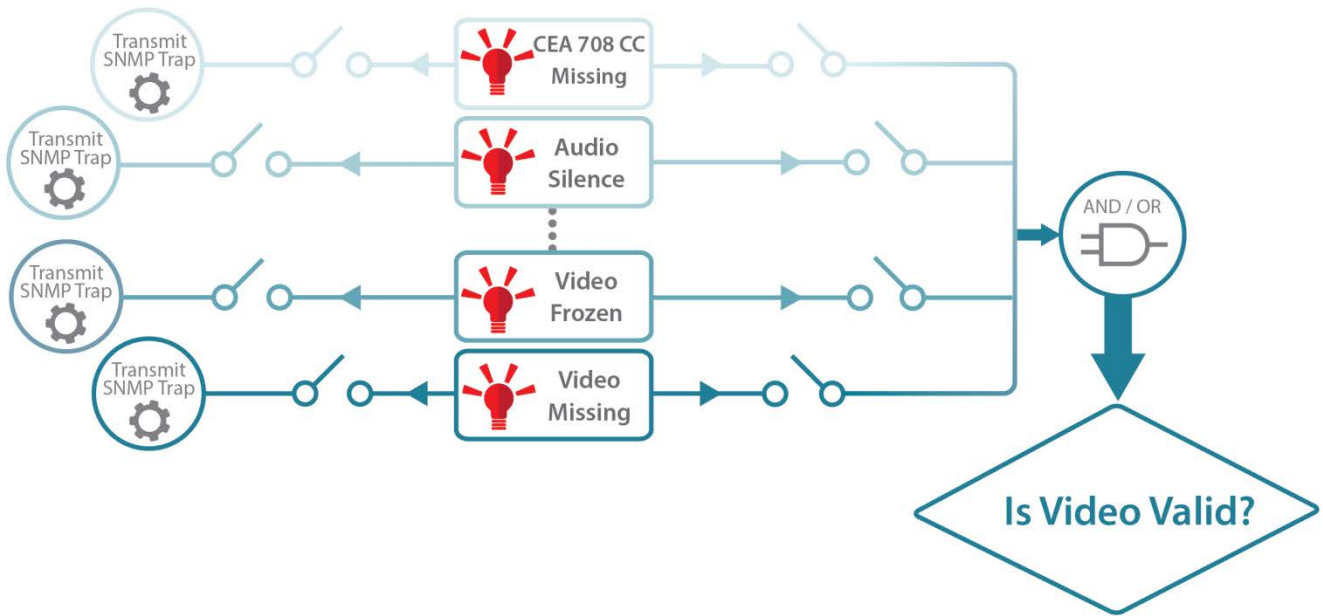
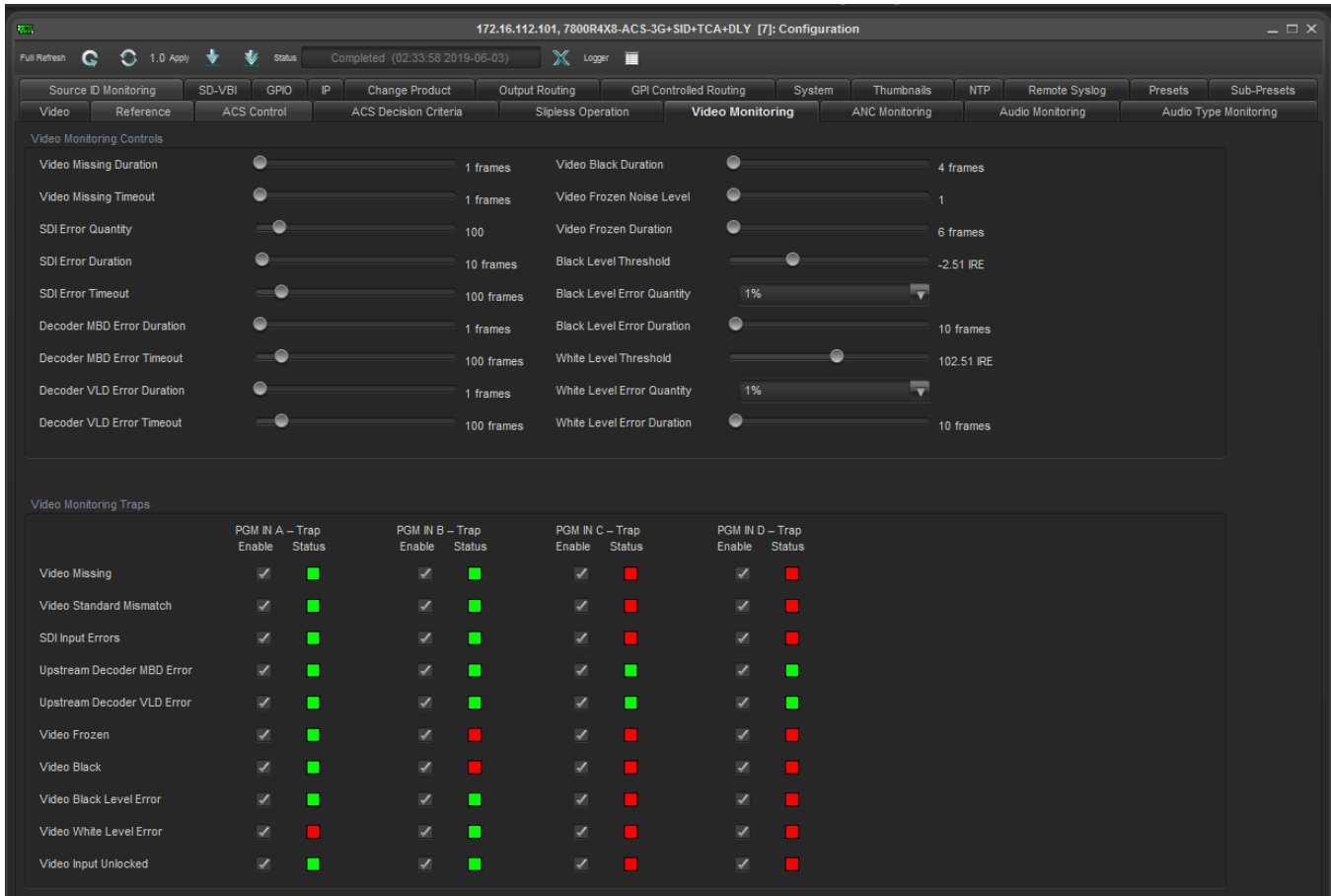

**Figure 5-8 : Connection Between Fault, Trap and ACS**

The following sections describe each Fault in detail and any associated controls that can be used to tune the Fault Detection.

### 5.5.1. Video Monitoring

This section describes the AVM parameters that monitor the health of the video.



**Figure 5-9 : VistaLINK® PRO - Video Monitoring Section**

#### 5.5.1.1. Video Monitoring Controls

**Video Missing:** Monitors for the presence of an input video signal. The *Video Missing FAULT* condition exists when a valid and supported input video signal is not present.

- **Video Missing Duration:** Sets the number of consecutive video frames that are marked as *Video Missing* before triggering a *Video Missing FAULT* condition. The value range is 1 to 900 frames.
- **Video Missing Timeout:** Sets the number of consecutive video frames that are NOT marked as *Video Missing* before a *Video Missing FAULT* condition will be CLEARED. The value range is 1 to 900 frames.

**Video Standard Mismatch:** Monitors the detected input video standard. The *video standard mismatch FAULT* condition exists when the detected input video standard does not match the module’s output video standard.

**SDI Input Errors:** Monitors the input SDI link for errors such as CRC errors, line length errors, and TRS errors.

- **SDI Error Quantity:** Sets the number of individual SDI input errors that must occur within a single video frame before the frame is marked as an ERROR frame. The value range is 1 to 1000 errors in increments of 1.
- **SDI Error Duration:** Sets the number of consecutive video frames that must be evaluated as an ERROR frame before triggering an *SDI Input Error* FAULT condition. The value range is 1 to 900 frames in increments of 1.
- **SDI Error Timeout:** This control sets the number of consecutive video frames that must be evaluated as NOT having an ERROR before the *SDI Input Error* FAULT will be CLEARED. This value range is 1 to 900 frames in increments of 1.

**Upstream Decoder MBD Error:** Monitors an Evertz Proprietary ANC packet that specifies if a Macro Block Decode Error occurred while an upstream video decoder was decoding the image. This metric indicates the potential of a bad image content that could not be otherwise detected.

- **Decoder MBD Error Duration:** Sets the number of consecutive video frames that are marked as having a *Macro Block Decode Error* before triggering an *Macro Block Decode Error* FAULT condition. The value range is 1 to 900 frames in increments of 1.
- **Decoder MBD Error Timeout:** Sets the number of consecutive video frames that are marked as NOT having a *Macro Block Decode Error* before an *Macro Block Decode Error* FAULT condition will be CLEARED. The value range is 1 to 900 frames in increments of 1.

**Upstream Decoder VLD Error:** Monitors an Evertz Proprietary ANC packet that specifies if a Variable Length Decode Error occurred while an upstream video decoder was decoding the image. This metric indicates the strong potential that the image content has been corrupted.

- **Decoder VLD Error Duration:** Sets the number of consecutive video frames that are marked as having a *Variable Length Decode Error* before triggering an *Variable Length Decode Error* FAULT condition. The value range is 1 to 900 frames in increments of 1.
- **Decoder VLD Error Timeout:** Sets the number of consecutive video frames that are marked as NOT having a *Variable Length Decode Error* before an *Variable Length Decode Error* FAULT condition will be CLEARED. The value range is 1 to 900 frames in increments of 1.

**Video Frozen:** Monitors the motion in the input video images. It will indicate an error when no motion is present because this indicates that the images are frozen.

- **Video Frozen Noise Level:** Sets the threshold at which image differences between consecutive frames are considered motion and not simply background noise. The value range is 1 to 10 in increments of 1.

As a guide, here are some signals to noise ratio comparisons:

1 = digital freeze (no noise on top of frozen picture)  
10 = 40 dB SNR

- **Video Frozen Duration:** Sets the number of consecutive video frames that are marked as being *Frozen* before triggering a *Video Frozen* FAULT condition. The value range is 6 to 9998 frames in increments of 4 video frames.



**NOTE:** When increasing the *Video Noise Level*, it is recommended that the *Video Frozen Duration* is increased as well. This is because the higher the picture noise level, the lower the equipment's motion sensitivity, thus long periods without significant on-screen movement are more likely to trigger an erroneous *Video Frozen* fault condition.

**Video Black:** Monitors the input video for black images below 7 IRE.

- **Video Black Duration:** Sets the number of consecutive video frames that are marked as being black before triggering a *Video Black* FAULT condition. The value range is 4 to 9996 frames in increments of 4 video frames.

**Video Black Level Error:** Monitors the input video for excessively dark pixels.

- **Black Level Threshold:** This control sets the brightness of active picture content (in IRE) below which a pixel is considered too black. The value range is -6.85 IRE to 7.19 IRE.
- **Black Level Error Quantity:** Sets the number of pixels below the *Black Level Threshold* in a single frame before the frame is marked as an ERROR frame. It is expressed as a percentage of active picture and can be set to the values: Any, 0.01%, 0.1%, 1%, 10% and 20%. A selection of Any will cause a frame of video to be in ERROR if a single video pixel is under the *Black Level Threshold*.
- **Black Level Error Duration:** Sets the number of consecutive video frames that must be evaluated as an ERROR frame before triggering a *Black Level Error* FAULT condition. The value range is between 1 frame and 900 frames.

**Video White Level Error:** Monitors the input video for excessively bright pixels.

- **White Level Threshold:** This control sets the brightness of active picture content (in IRE) above which a pixel is considered too bright. The value range is 94.98 IRE and 109.02 IRE.
- **White Level Error Quantity:** Sets the number of pixels above the *White Level Threshold* in a single frame before the frame is marked as an ERROR frame. It is expressed as a percentage of active picture and can be set to the values: Any, 0.01%, 0.1%, 1%, 10% and 20%. A selection of Any will cause a frame of video to be in ERROR if a single video pixel is above the *White Level Threshold*.
- **White Level Error Duration:** Sets the number of consecutive video frames that must be evaluated as an ERROR frame before triggering a *White Level Error* FAULT condition. The value range is between 1 frame and 900 frames.

**Video Input Unlocked:** Monitors the input video's phase to determine if it is clock locked to the module's output video. This parameter does not look for a specific phase relationship, just a constant phase. A *Video Input Unlocked* FAULT condition exists when the phase of the input video is drifting with respect to the 7800R4x8-ACS's output video.

### 5.5.1.2. Video Monitoring Traps

Each fault outlined in section 5.5.1.1 can generate an SNMP trap to alert the users. To enable/disable a specific fault trap, check/uncheck the corresponding checkbox in the Video Monitoring Traps section.



**NOTE:** The SNMP trap enable for a FAULT is independent of its inclusion in the ACS switching decision criteria. For example, it might be desirable for the ACS logic to automatically switch away from an input with an *SDI Input Error* FAULT because that parameter is unlikely to generate a false positive. In contrast, it might be desirable for a human to evaluate a *Video Frozen* FAULT because slow moving content can fool the measurement into a false positive situation. In this case, a trap can be used to alert the user to evaluate the situation.

### 5.5.2. ANC Monitoring

This section describes the AVM parameters that monitor the health of the Ancillary Data packets.

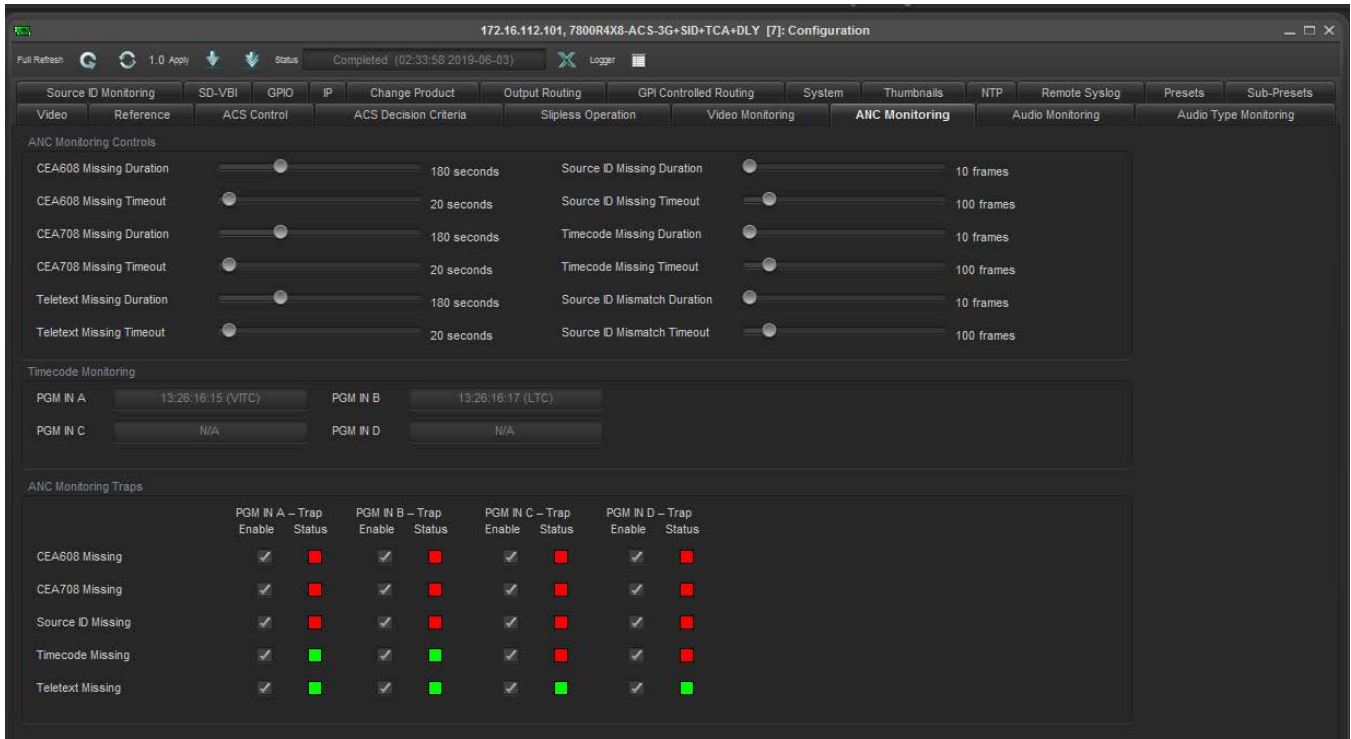

**Figure 5-10 : VistaLINK® PRO - ANC Monitoring Section**

#### 5.5.2.1. ANC Monitoring Controls

**CEA608 Missing:** Monitors the input for the presence of CEA608 caption data. When CEA 608 data is carried via the SD VBI waveform, this metric simply monitors the presence of the waveform. When the CEA 608 data is carried via a CDP ANC packet, this metric simply looks for the presence of the 608 data inside the CDP packet. It should be noted that any data (including NULL) is considered valid data and that the caption data is not decoded. See Section 5.7.1 for information on how to configure CEA608 reading for SD video.

- **CEA608 Missing Duration:** Sets the number of consecutive video frames (in seconds) that must not contain any CEA 608 data before triggering a *CEA608 Missing* FAULT condition. The value range is between 1 second and 600 seconds in increments of 1 second.
- **CEA608 Missing Timeout:** This control sets the number of consecutive video frames (in seconds) that must contain CEA 608 caption data before the *CEA608 Missing* fault will be CLEARED. The value range is between 1 second and 600 seconds in increments of 1 second.

**CEA708 Missing:** Monitors the input for the presence of CEA708 caption data. This metric simply looks for the presence of 708 data inside the CDP ANC packet. It should be noted that any data (including NULL) is considered valid data and that the caption data is not decoded.

- **CEA708 Missing Duration:** Sets the number of consecutive video frames (in seconds) that must not contain any CEA 708 data before triggering a *CEA708 Missing* FAULT condition. The value range is between 1 second and 600 seconds in increments of 1 second.
- **CEA708 Missing Timeout:** This control sets the number of consecutive video frames (in seconds) that must contain CEA 708 caption data before the *CEA708 Missing* fault will be CLEARED. The value range is between 1 second and 600 seconds in increments of 1 second.

**Source ID Missing:** Monitors the input for the presence of the Source ID ANC Packet. This metric simply monitors the presence of the Source ID ANC Packet and does not decode the packet to verify its validity. See Section 5.5.5.1 for information on how to configure the Source ID DID value.

- **Source ID Missing Duration:** Sets the number of consecutive video frames that must not contain a Source ID ancillary data packet before triggering a *Source ID Missing* FAULT condition. The value range is between 1 frame and 900 frames in increments of 1 frame.
- **Source ID Missing Timeout:** This control sets the number of consecutive video frames that must contain Source ID ancillary data before the *Source ID Missing* fault will be CLEARED. The value range is between 1 frame and 900 frames in increments of 1 frame.

**Time Code Missing:** Monitors the input for the presence of a Time Code ANC Packet. This metric simply monitors the presence of the ANC Packet and does not verify that it is valid. When Time Code data is carried via an SD VBI waveform, this metric simply monitors the presence of the waveform. When the Time Code data is carried via an ANC packet, this metric simply looks for the presence of the ANC packet. See Section 5.7.1 for information on how to configure Time Code reading for SD video.

- **Time Code Missing Duration:** Sets the number of consecutive video frames that must not contain a Time Code data before triggering a *Time Code Missing* FAULT condition. The value range is between 1 frame and 900 frames in increments of 1 frame.
- **Time Code Missing Timeout:** This control sets the number of consecutive video frames that must contain Time Code data before the *Time Code Missing* fault will be CLEARED. The value range is between 1 frame and 900 frames in increments of 1 frame.

**Teletext Missing:** Monitors the input for the presence of Teletext data. When Teletext data is carried via the SD VBI waveform, this metric simply monitors the presence of all enabled waveforms. When the Teletext data is carried via an ANC packet, this metric simply looks for the presence of the packet. It should be noted that any data (including NULL) is considered valid data and that the Teletext data is not decoded. See Section 5.7.2 for information on how to configure Teletext reading for SD video.

- **Teletext Missing Duration:** Sets the number of consecutive video frames (in seconds) that must not contain any Teletext data before triggering a *Teletext Missing* FAULT condition. The value range is between 1 second and 600 seconds in increments of 1 second.
- **Teletext Missing Timeout:** This control sets the number of consecutive video frames (in seconds) that must contain Teletext data before the *Teletext Missing* fault will be CLEARED. The value range is between 1 second and 600 seconds in increments of 1 second.



**Source ID Mismatch:** Monitors the content of the Source ID packet. This metric determines if the fields in the Source ID packet match the expected values. See section 5.5.5 for more details.

- **Source ID Mismatch Duration:** Sets the number of consecutive video frames that must contain a *Source ID Mismatch* before triggering a *Source ID Mismatch FAULT* condition. The value range is between 1 frame and 900 frames in increments of 1 frame.
- **Source ID Mismatch Timeout:** Sets the number of consecutive video frames that must not contain a *Source ID Mismatch* before a *Source ID Mismatch FAULT* condition will be CLEARED. The value range is between 1 frame and 900 frames in increments of 1 frame.

### 5.5.2.2. ANC Monitoring Traps

Each fault outlined in section 5.5.2.1 can generate an SNMP trap to alert the users. To enable/disable a specific fault trap, check/uncheck the corresponding checkbox in the ANC Monitoring Traps section.



**NOTE:** The SNMP trap enable for a FAULT is independent of its inclusion in the ACS switching decision criteria. For example, it might be desirable for the ACS logic to automatically switch away from an input with an *SDI Input Error FAULT* because that parameter is unlikely to generate a false positive. In contrast, it might be desirable for a human to evaluate a *Video Frozen FAULT* because slow moving content can fool the measurement into a false positive situation. In this case, a trap can be used to alert the user to evaluate the situation.

### 5.5.3. Audio Monitoring

This section describes the AVM metrics that monitor the health of the Audio data.

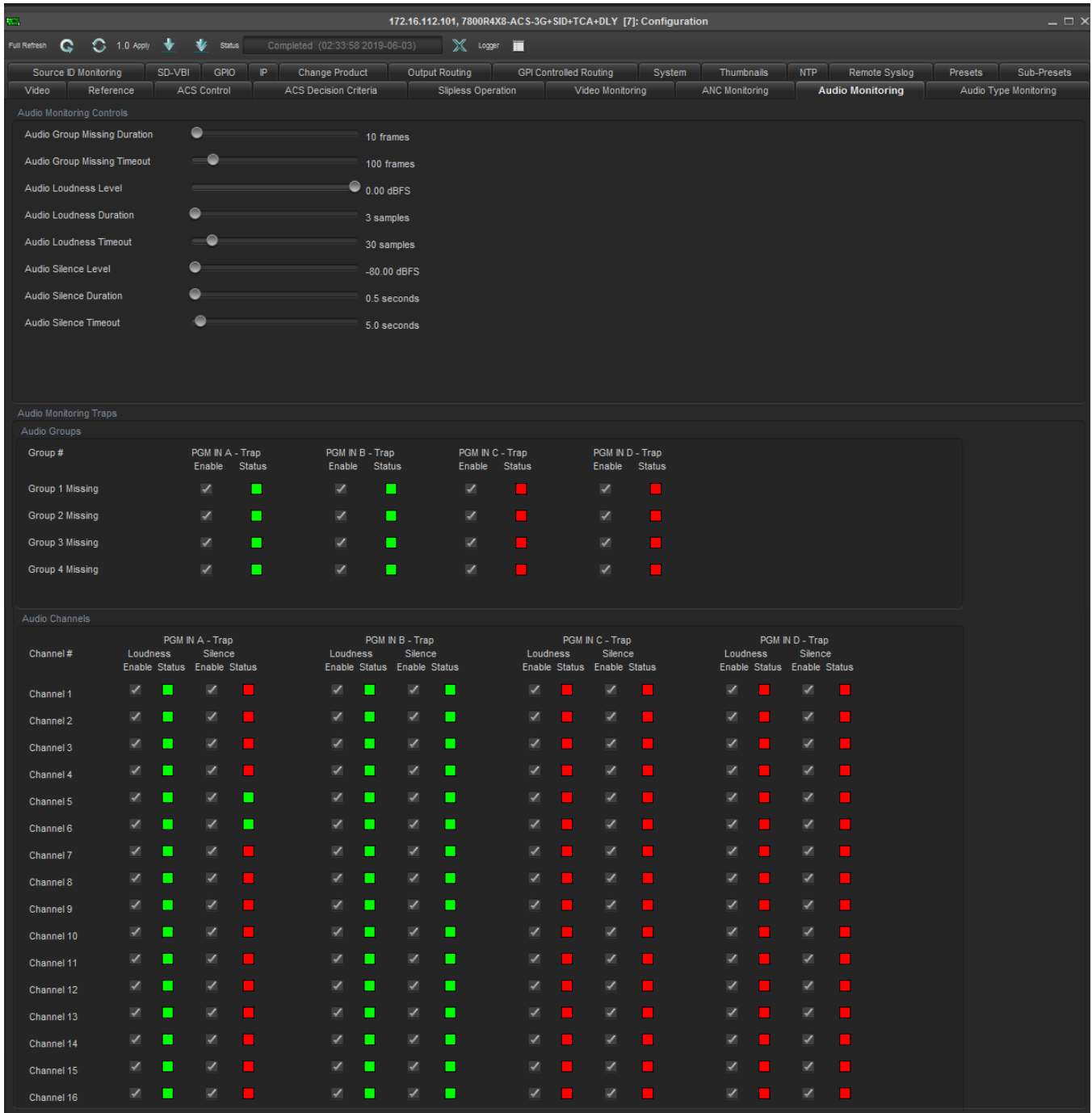

**Figure 5-11 : VistaLINK® PRO - Audio Monitoring Section**

#### 5.5.3.1. Audio Monitoring Controls

**Group <1-4> Missing:** Monitors the input for the presence of embedded audio HANC packets (SMPTE ST299-1) containing data for the corresponding group. This metric strictly checks the audio data structure but does not analyze the audio essence.

- **Audio Group Missing Duration:** Sets the number of consecutive video frames that must not contain embedded audio data for the corresponding audio group before triggering a *Group <1-4> Missing FAULT* condition. The value range is 1 to 900 frames in increments of 1.
- **Audio Group Missing Timeout:** Sets the number of consecutive video frames that must contain embedded audio data for the corresponding audio group before the corresponding *Group <1-4> Missing FAULT* will be CLEARED; the value range is 1 to 900 frames in increments of 1.

**Audio CH <1-16> Loudness:** Monitors the corresponding channel's audio essence to verify that the audio is not too loud. The audio is preprocessed with a peak detector that decays at approximately 12dB / second.

- **Audio Loudness Level:** Sets the volume level over which the audio is considered to be too loud. This value is expressed in dB full scale (FS). The value range is -30.00 to 0.00 dB in increments of 0.25 dB.
- **Audio Loudness Duration:** Sets the number of consecutive audio samples that evaluated as an Audio Loudness ERROR sample before triggering an *Audio Loudness FAULT* condition for the corresponding audio channel (Channels 1-16). The value range is between 3 samples and 255 samples.
- **Audio Loudness Timeout:** Sets the number of consecutive audio samples that evaluated as NOT having an Audio Loudness ERROR before the *Audio Loudness FAULT* condition will be CLEARED for the corresponding audio channel (Channels 1-16). The range is between 3 samples and 255 samples.

**Audio CH <1-16> Silence:** Monitors the corresponding channel's audio essence to verify that the audio is not too quiet.

- **Audio Silence Level:** Sets the level of the audio peak detector under which the audio is considered to be quiet. This value is expressed in dB full scale (FS). The value range is from -80.00 to -45.00 dB in 0.25 dB increments.
- **Audio Silence Duration:** Sets the number of consecutive audio samples that evaluated as an Audio Silence ERROR sample before triggering an *Audio Silence FAULT* condition for the corresponding audio channel (Channels 1-16). The value range is between 0.5 seconds and 127.0 seconds in increments of 0.5 seconds.
- **Audio Silence Timeout:** Sets the number of consecutive audio samples that evaluated as NOT having an Audio Silence ERROR before the *Audio Silence FAULT* condition will be CLEARED for the corresponding audio channel (Channels 1-16). The value range is between 0.5 seconds and 127.0 seconds in increments of 0.5 seconds.

### 5.5.3.2. Audio Monitoring Traps

Each fault outlined in section 5.5.3.1 can generate an SNMP trap to alert the users. To enable/disable a specific fault trap, check/uncheck the corresponding checkbox in the Audio Monitoring Traps section.



**NOTE:** The SNMP trap enable for a FAULT is independent of its inclusion in the ACS switching decision criteria. For example, it might be desirable for the ACS logic to automatically switch away from an input with an *SDI Input Error FAULT* because that parameter is unlikely to generate a false positive. In contrast, it might be desirable for a human to evaluate a *Video Frozen FAULT* because slow moving content can fool the measurement into a false positive situation. In this case, a trap can be used to alert the user to evaluate the situation.

### 5.5.4. Audio Type Monitoring

The Audio Type Metrics are used to verify that the type of audio (PCM, Dolby-E, Dolby-AC3, Dolby-EAC3) is consistent with what is expected.

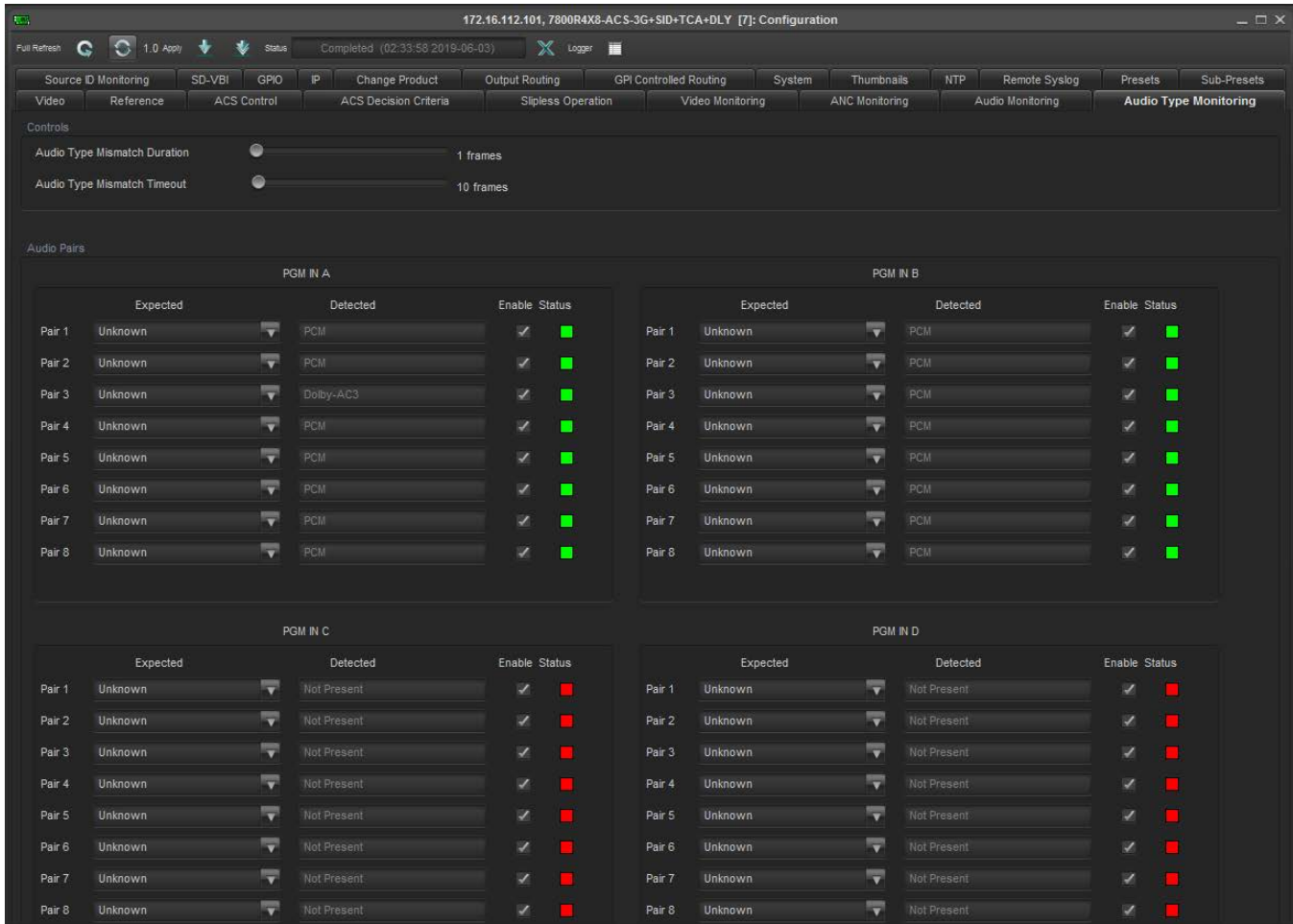

**Figure 5-12 : VistaLINK<sup>®</sup> PRO - Audio Type Monitoring Section**

**Audio Type Mismatch Duration:** Sets the number of consecutive video frames where the Audio Type does not match the Expected Audio for a particular Audio Pair before triggering an *Audio Type Mismatch* FAULT condition. The value range is between 1 frame and 900 frames in increments of 1 frame.

**Audio Type Mismatch Timeout:** Sets the number of consecutive video frames where the Audio Type does not match the Expected Audio for a particular Audio Pair before an *Audio Type Mismatch* FAULT condition will be CLEARED. The value range is between 1 frame and 900 frames in increments of 1 frame.

**PGM IN <A,B,C,D> Audio Pair <1-8> Expected Type:** This control specifies the Expected Audio Type for a particular Audio Pair. The options are “Unknown”, “PCM”, “Dolby-E”, “Dolby-AC3”, and “Dolby-EAC3”. When “Unknown” is selected, the Audio Type Mismatch Metric will not be active for that audio pair.

**PGM IN <A,B,C,D> Audio Pair <1-8> Detected Type:** This status reports the detected Audio Type for a particular Audio Pair. “Not Present” will be reported when the Audio Pair is not present.

**5.5.5. Source ID Monitoring**

**Source Identification** (*termed Source ID*) provides a useful method for tagging the video signal with an ancillary data packet as it is processed by a module with Source ID authoring capabilities. Each Source ID authoring capable module can append its own source ID tag into the ANC region of the processed video signal. This effectively creates a history of the signal processing path taken by any video signal through the facility.

Each Source ID tag ancillary packet payload is 113 bytes and is defined as follows:

Element	Bytes
Version	1
SID Count & Overflow	2
Date (DDMMYY)	6
Time (HHMMSSFF)	8
Time Zone	4
Base Label	16
Alias Label	48
User Code	4
Alpha Tag	12
Serial Tag	12
<b>Total Payload per SID tag</b>	<b>113</b>

**Table 5-4 : Source ID - VANC Packet Payload**

All data within the source ID packet is ASCII encoded to allow for simple decoding and monitoring of any element within the source ID packet.

The Source ID Monitoring section reports to the user status of the complete Source ID tag embedded in the input video signal. This simple status interface gives the user a glance into the contents of any Source ID tag embedded in the input video signal.

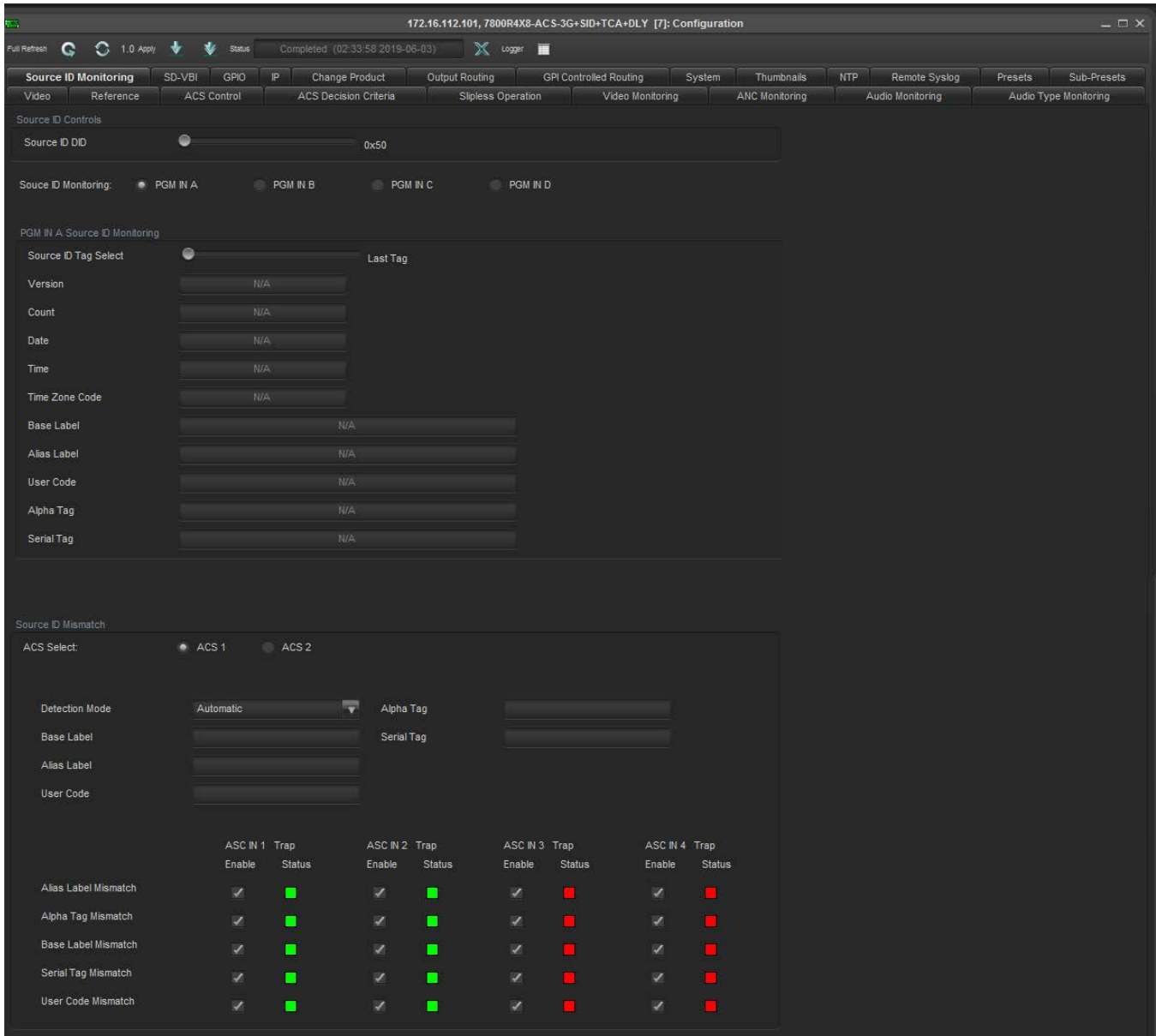

**Figure 5-13 : VistaLINK® PRO - Source ID Monitoring Section**

**5.5.5.1. Source ID Controls**

**Source ID DID:** This control sets the Data Identification (DID) value for the Source ID SMPTE-291 packets.



**NOTE:** This value is used to read all Source ID packets in the system. This must be correctly set for the Slipless Alignment algorithm to use Source ID ANC packets.

### 5.5.5.2. PGM IN <A,B,C,D> Source ID Monitoring

**Source ID Tag Select:** This control allows setting the Source ID tag to actively monitor based on the SID count embedded in the Source ID tag packet. When *Last Tag* is selected, the module will report the status of the Source ID tag with the largest *SID Count*. This control can be independently set for each input video signal (*PGM IN A*, *PGM IN B*, *PGM IN C* and *PGM IN D*).



**NOTE:** *Source ID Tag Select* does not determine which Tag is used for temporal alignment, nor does it determine if a fault has occurred. The last tag in the input video signal is always used for these purposes.

**Version:** This reports the Source ID tag *VERSION* field.

**Count:** This reports the Source ID tag *SID COUNT & OVERFLOW* field. This field will match the value set by the *Source ID Tag Select* control unless the control is set to *Last Tag*. In that case, it will report the largest *SID Count* present on the input signal.

**Date:** This reports the Source ID tag *DATE* field. The date field is formatted DDMMYY, and represent the date when the Source ID tag was embedded onto the video signal.

**Time:** This reports the Source ID tag *TIME* field. The time field is formatted HHMMSSFF, and represent the system time of the Source ID authoring module when the Source ID tag was embedded onto the video signal.

**Time Zone Code:** This reports the Source ID tag *TIME ZONE* field. The time zone code represents the time zone of the Source ID authoring module when the Source ID tag was embedded onto the video signal.

**Base Label:** This reports the Source ID tag *BASE LABEL* field. This field provides the primary identification of the module authoring the Source ID tag. The base label is a maximum of 16 characters.

**Alias Label:** This reports the Source ID tag *ALIAS LABEL* field. This field provides the additional secondary identification of the module authoring the Source ID tag. The alias label is 48 characters and is used for a more detailed description of the module.

**User Code:** This reports the Source ID tag *USER CODE* field. This field is a 4 digit utility number available for user monitoring applications of Source ID. One possible use case would be to set the user code as the router input / output number that the module authoring the Source ID tag is connected to. The value range is 0000 – 9999.

**Alpha Tag:** This reports the Source ID tag *ALPHA TAG* field. This field provides a 12 character identification of the owner of the module authoring the Source ID tag.

**Serial Tag:** This reports the Source ID tag *SERIAL TAG* field. This is a 12 character field that contains the serial number of the module authoring the Source ID tag.

### 5.5.5.3. Source ID Mismatch Traps

There is an associated *FAULT* for each field in the Source ID packet that will alarm when the value inside the field does not match the expected Source ID value. The expected Source ID value is defined by the *Detection Mode* control. These *FAULTS* can generate an SNMP trap by appropriately setting the enable/disable the corresponding checkbox.

**Detection Mode:** This control selects how the module determines what the expected Source ID value is for the purposes of the Source ID Mismatch FAULTS. When set to “Automatic” the expected value is updated every frame and defined as the Source ID packet embedded in the last Program Output video frame. When set to “Manual” mode, the expected value is defined by the user controls.

**Base Label:** This control selects the expected *BASE LABEL* when Source ID Detection Mode is set to Manual.

**Alias Label:** This control selects the expected *ALIAS LABEL* when Source ID Detection Mode is set to Manual.

**User Code:** This control selects the expected *USER CODE* when Source ID Detection Mode is set to Manual.

**Alpha Tag:** This control selects the expected *ALPHA TAG* when Source ID Detection Mode is set to Manual.

**Serial Tag:** This control selects the expected *SERIAL TAG* when Source ID Detection Mode is set to Manual.

**Alias Label Mismatch:** Triggers a FAULT trap when the ALIAS LABEL field within the last Source ID tag differs between the Expected Source ID and the corresponding input video.

**Alpha Tag Mismatch:** Triggers a FAULT trap when the ALPHA TAG field within the last Source ID tag differs between the Expected Source ID and the corresponding input video.

**Base Label Mismatch:** Triggers a FAULT trap when the BASE LABEL field within the last Source ID tag differs between the Expected Source ID and the corresponding input video.

**Serial Tag Mismatch:** Triggers a FAULT trap when the SERIAL TAG field within the last Source ID tag differs between the Expected Source ID and the corresponding input video.

**User Code Mismatch:** Triggers a FAULT trap when the USER CODE field within the last Source ID tag differs between the Expected Source ID and the corresponding input video.



**NOTE:** All Source ID fault status and traps are based on the comparison of the LAST SOURCE ID TAG present on each input video signal.



## 5.6. ACS DECISION CRITERIA

The ACS Decision Criteria control section contains a list of checkboxes that are used to determine how each ACS Processor will determine if the input video source is VALID or INVALID. To understand the ACS Decision Criteria, it is important to understand that each choice refers to an underlying Fault condition (see Figure 5-14). The details of these faults have been explained in the previous sections of this manual and many of them have controls that allow the user to tune the detection for their particular system. Refer to section 5.5 for definitions of ACS Decision Criteria fields. Select the checkbox beside a particular fault to indicate this fault is significant enough to cause the input video to be considered INVALID.

The ACS Decision Criteria for each ACS Processor can be independently configured to allow for a different set of expectations. This independence adds a considerable amount of flexibility. It allows one ACS to require Audio to be present for the video to be considered VALID while another ACS might not. This allows the module to work on multi link systems where Link-A will typically carry all of the audio information while Link-B contains no audio.

### 5.6.1. Invalid Video Logic

When multiple Faults are enabled they can be combined in two different ways.

**ANY:** Consider that the input video INVALID when any of the selected faults are present.

**ALL:** Consider the input video INVALID only when all of the selected faults are present.

### 5.6.2. Fault Cancellation Mode

The ACS Processor can take advantage of the fact that the content is expected to be identical when selecting between a set of redundant links. Once the inputs have been temporally aligned, it is expected that the AVM metrics will be identical for each frame. This knowledge can be leveraged in order to allow the system to recognize faults more quickly.

When Fault Cancellation Mode is enabled we take advantage of the knowledge that we expect the content of all the inputs to be identical and any fault that exists on all of the inputs to a particular ACS Processor will be cleared. These common faults are considered erroneous faults and will not cause an input to be considered INVALID. This allows the *thresholds* and *durations* for the various faults to be configured to react very quickly without causing the inputs to be considered INVALID whenever the metrics produce a false positive result.

When Fault Cancellation Mode is disabled we treat all inputs independently and any fault that exists on all of the inputs to a particular ACS Processor will cause all inputs to be considered INVALID. The validity of a particular input is based solely on the ACS Decision Criterion and the Invalid Video Logic.

The ability to cancel out erroneous faults allows each of the AVM parameters to be tuned to react quickly without causing the inputs to be considered INVALID when they are not. This is a powerful tool and, if utilized correctly, will allow content related errors to be detected quickly. For example, in order to decrease the reaction time it might be desirable to configure the Audio Silence Fault so that it will enter the Fault state after 0.5 seconds of quiet audio. The Audio Silence Fault will react very quickly to a real Audio Silence error, but it will also cause the video to frequently become INVALID. When Fault Cancellation is enabled, the Audio Silence Fault is cleared when it exists on all of the ACS inputs. It is not considered when determining if an input is VALID or INVALID. The result is quick detection of Audio Silence without the undesirable false positive INVALID video caused by the erroneous Audio

Silence Faults. In fact, this detection time is small enough that the delay required to completely avoid allowing an Audio Silence Fault through the ACS Processor is possible. Contrast this with the traditional setting for Audio Silence Duration of 45 seconds and the benefit can clearly be seen. Without Fault Cancellation, the Program output would contain about 45 seconds of silence before the Fault was detected and the ACS Processor switched away. With Fault Cancellation, the Audio Silence Fault could be detected in as little as 0.5 seconds allowing the fault to be completely avoided if the module's latency was larger than 0.5 seconds.



**NOTE:** It is recommended that you disable this feature when the inputs to an ACS Processors are not expected to contain identical content and to be temporally aligned.



**NOTE:** The exact behaviour of the Clean Switch will depend upon the settings on the ACS Control section but in all cases the system attempts to avoid any input that is considered INVALID. See section 5.3.1 for more details about the automatic Change-Over processing modes (*Auto Switch Back, Auto Switch & Auto Non-Revertive*).

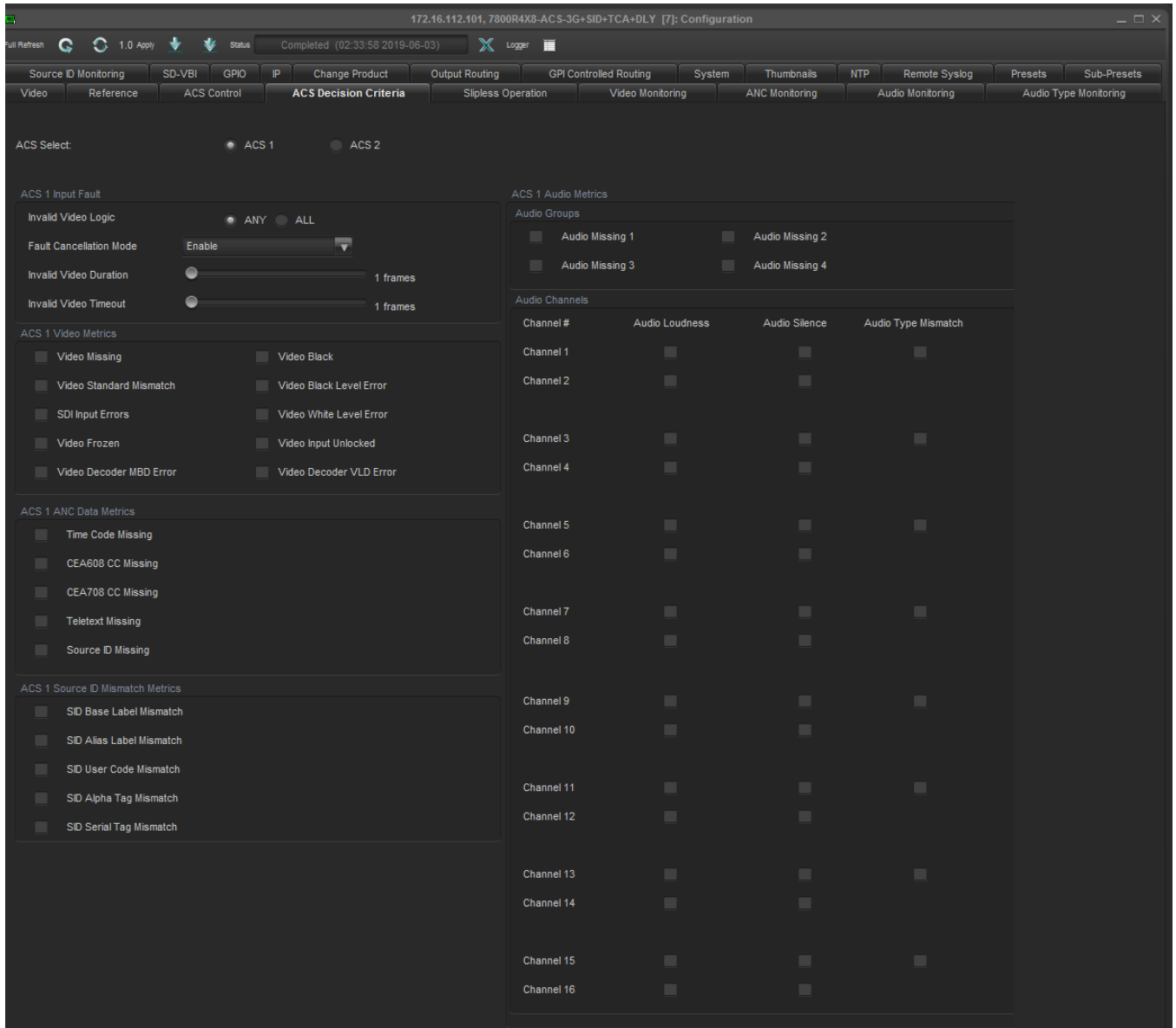

**Figure 5-14 : VistaLINK® PRO - ACS Decision Criteria Section**

### 5.7. SD-VBI

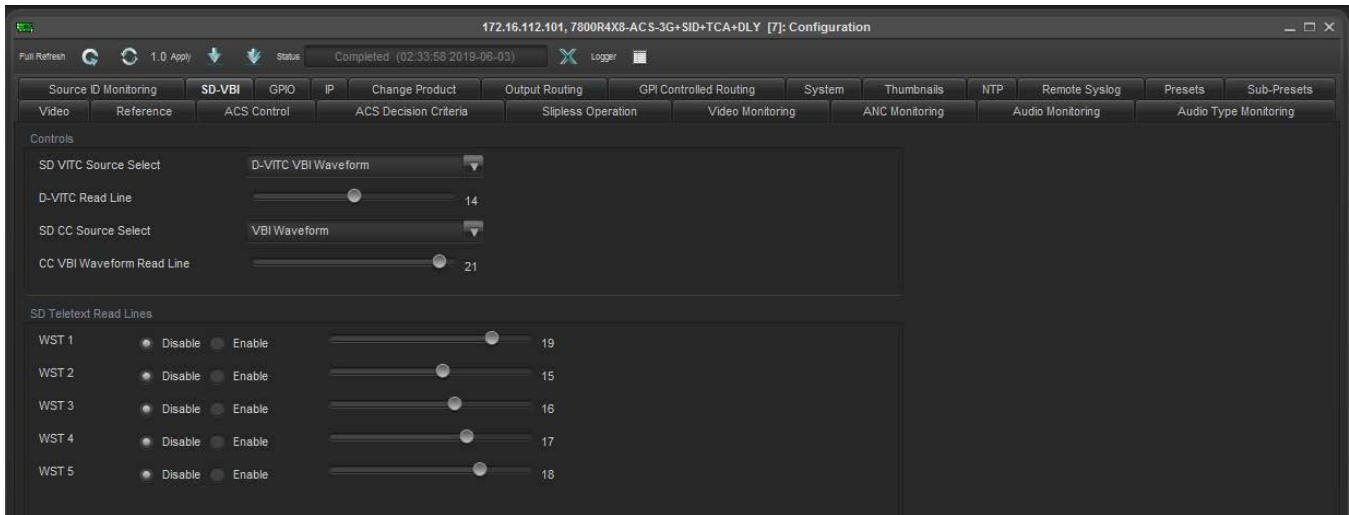

Figure 5-15 : VistaLINK® PRO – SD-VBI Section

#### 5.7.1. SD VITC Configuration

**SD VITC Source Select:** Time Code can be transported using two very different methods in SD video. It can be encoded using a D-VITC VBI waveform, or it can be embedded in a digital ANC Packet. This control selects where the module should look for VITC Time Code. Select D-VITC VBI Waveform to read the VITC waveform from the line specified by the user control D-VITC Read Line. Select Digital ANC Packet to use the Time Code value from the SMPTE 12 digital Ancillary Data Packet.

**D-VITC Read Line:** This control selects which video line number has the D-VITC waveform and is only applicable when the SD VITC Source Select is set to D-VITC VBI Waveform.



**NOTE:** It is not necessary to provide a read line number when SD VITC Source Select is set to Digital ANC Packet. The ANC Packet reader will search the entire VANC and HANC region to find the packet.

#### 5.7.2. SD Closed Caption Configuration

**SD CC Source Select:** CEA 608 Closed Caption information can be transported using two very different methods in SD video. It can be encoded using a CC VBI waveform (typically on line 21), or it can be embedded in a digital ANC Packet. This control selects where the module should look for CC data. Select VBI Waveform to read the CC waveform from the line specified by the user control CC VBI Waveform Read Line. Select CDP to use the CEA 608 CC data from the CDP Digital Ancillary Data Packet.

**CC VBI Waveform Read Line:** This control selects which video line number has the CC waveform and is only applicable when the SD CC Source Select is set to VBI Waveform.



**NOTE:** It is not necessary to provide a read line number when SD CC Source Select is set to CDP. The ANC Packet reader will search the entire VANC and HANC region to find the packet.

### 5.7.3. SD Teletext Read Line

**WST 1-5 Input Enable:** This control *enables/disables* the WST Input processing for the corresponding WST Input stream. This control applies only for 625i/50Hz (SD) input video signals. When enabled, the module will monitor the corresponding WST Input stream and expect its presence.

**WST 1-5 Input Line Number:** This control specifies the VANC line number where the corresponding WST waveform is located. This control applies only for 625i/50Hz (SD) input video signals.

### 5.8. GPIO

The 7800R4X8-ACS module includes 8 GPIO pins. The GPIO control section provides user configuration of the GPIO. All 8 GPIO pins are independently configurable, and each GPIO has an identical set of controls. For electrical characteristics and pinout of the GPIO pins on the DB-9 connector, please refer to Section 2.3. Figure 5-16 illustrates the layout of the controls in the VistaLINK® PRO configuration view.

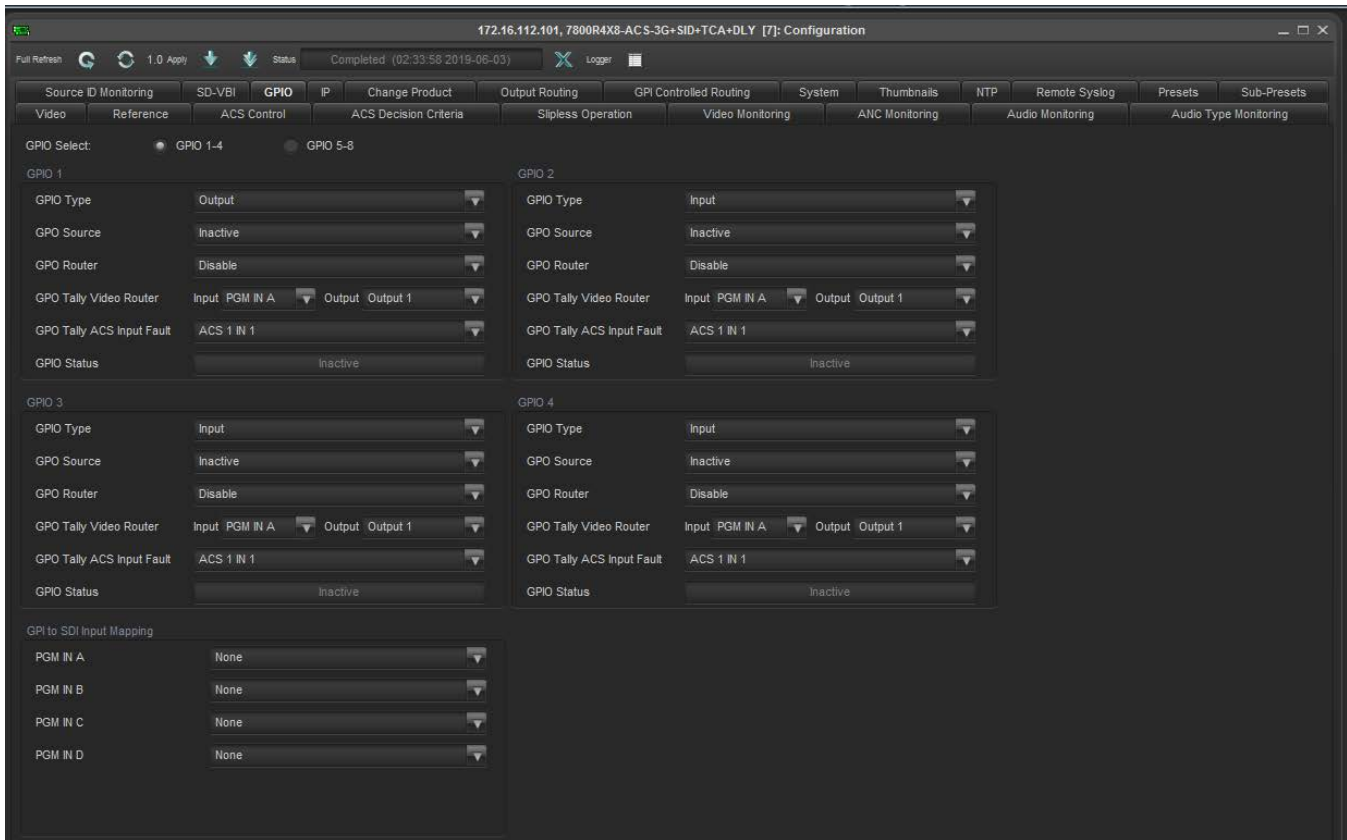

**Figure 5-16 : VistaLINK® PRO - GPIO Section**

#### GPIO <1-4 and 5-8>

**GPIO Type:** This control sets the direction on the specified GPIO pin as either an *Input* or an *Output* pin.

**GPO Source:** This control sets the source that can drive the state on the GPO output pin. This control is only applied when the *GPIO Type* is set to *Output*.

<b>Active</b>	The GPO is forced into an Active State by the module.
<b>Inactive</b>	The GPO is not driven by the module. It will be pulled up to the Inactive State if not being driven by an external source.
<b>GPO Router</b>	The GPIO Router system will control the GPO's state.
<b>Tally Video Router</b>	The GPO will reflect the status of the Video Router.
<b>Tally ACS Input Fault</b>	The GPO will reflect the status of the validity of a virtual ACS Input.

**Table 5-5 : GPO Sources**

**GPO Router:** The 7800R4x8-ACS product also has a GPIO router system that works in tandem with the video router. The use of a GPO to control downstream devices can often simplify system integration. Often these GPO control signals carry information about a certain video frame and must remain temporally aligned with the video. When operating in one of the automatic slipsless modes the 7800R4x8-ACS module may introduce a different delay for each video path in order to temporally align the inputs. This delay is potentially significant and inconsistent which would make it difficult to pass GPIO signals across the redundant switch if it wasn't for the GPO Router. The GPO Router will automatically delay and route each input video's GPI so that an output video's GPO will reflect the state of the GPI that was associated with the video frame currently being transmitted. It can be seen in Figure 5-17 and Figure 5-18 that the Video and GPIO data are delayed by the same amount and that the GPO router's selection is governed by the Video Router.

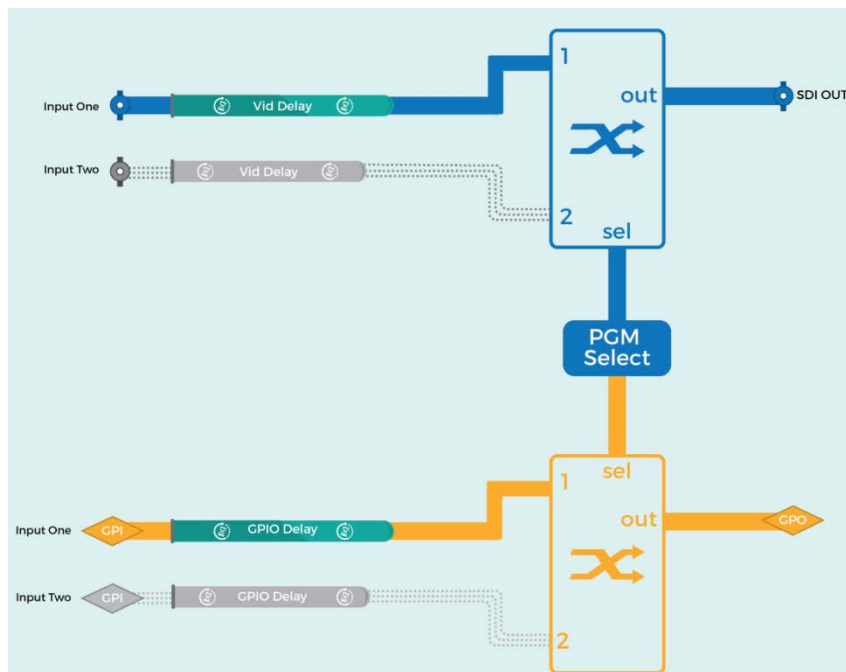

**Figure 5-17 : Video / GPO Router Interaction - Select 1**

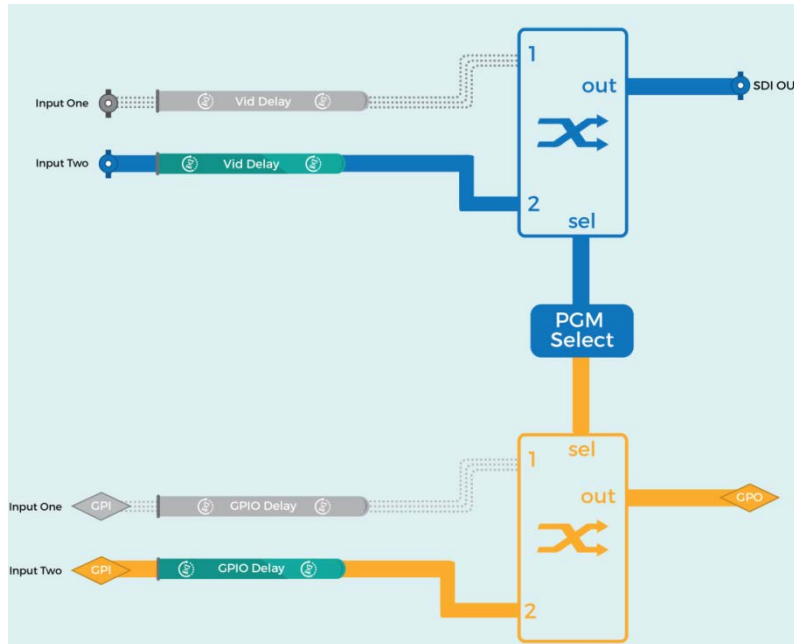

**Figure 5-18 : Video / GPO Router Interaction - Select 2**

In order to configure the GPIO router system you must associate a GPI to the SDI inputs and then associate GPOs with SDI outputs.

- Use the *GPI To SDI Mapping* controls to associate a GPI with each video input.
- Use the *GPO Source* controls to enable the GPO to be controlled by the GPO Router.
- Use the *GPO Router* controls to associate the GPO with a particular physical SDI output.

Once configured, the GPIO router will sample the state of an associated GPI each input video frame. The GPI state is then delayed and routed along with its input video frame. The GPO router is not independent and its input selection will always match that of the video router. This ensures that the state of each GPO associated with a physical SDI output will reflect the GPI associated with the currently routed video input.

**GPO Tally Video Router:** When the *GPO Source* is set to *Tally Video Router*, the GPO will be activated whenever the input video specified by the *GPO Tally Video Router Input* control is being used as the source for the Output Video specified by the *GPO Tally Video Router Output* control. This allows a GPO to reflect the status of the video router.

**GPO Tally ACS Input Fault:** When the *GPO Source* is set to *Tally ACS Input Fault*, the GPO will be activated whenever the virtual ACS input specified by the *GPO Tally ACS Input Fault* control is considered INVALID by the ACS Decision Criteria.

**GPIO Status:** This reports the current state of the corresponding GPIO pin. This status is valid regardless of the GPIO's direction. It can be used to validate that the module is properly detecting the state on a GPI pin as well as to check the current state of a GPO pin.





**NOTE:** GPIO pins are an open collector type interface. The GPIO Status may be active because the module is internally pulling the pin low, or it could be activated because an external device is pulling the pin low.

### 5.9. IP

Although the module does not currently support direct SNMP access, it is strongly recommended that an IP connection be established. The 7800R4x8-ACS is often used in the context of a very complex systems and this connection will allow the Evertz Service Team to gather information that will assist in tracking down the root cause of unexpected behaviour.

The IP section presents the 7800R4x8-ACS networking configuration controls. Figure 5-19 illustrates the layout of the controls in the VistaLINK® PRO configuration view.

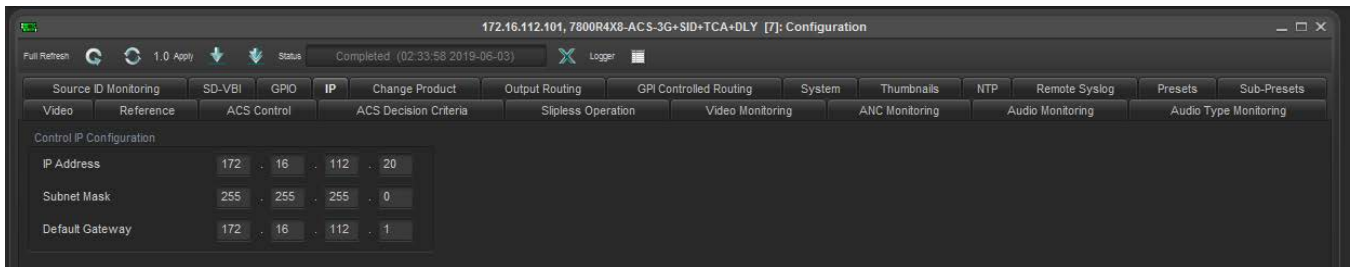

Figure 5-19 : VistaLINK® PRO - IP Section

#### 5.9.1. Control IP Configuration

**IP Address:** This control sets the *IP address* of the module.

**Subnet Mask:** This control sets the *subnet mask* of the module.

**Default Gateway:** This control sets the *default gateway* of the module, which will allow the card to communicate with devices on other networks.

### 5.10. CHANGE PRODUCT

This configuration section provides the ability to perform product string changes. There are software based product options on the 7800R4x8-ACS that can be added to a module at any point using these configuration controls. See Section 7.3 for more details on the process of adding product options.



**NOTE:** A unique Checksum must be generated to support a product string change on the 7800R4x8-ACS. Please contact Evertz if you are interested in upgrading the feature set of your 7800R4x8-ACS.

Figure 5-20 illustrates the layout of the controls in the VistaLINK® PRO module configuration view.

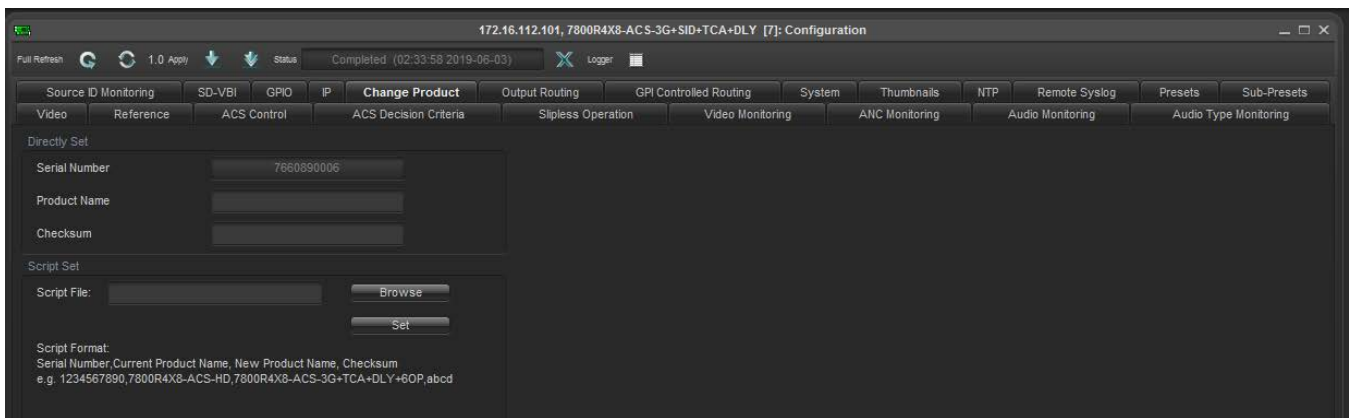

Figure 5-20 : VistaLINK® PRO - Change Product Section

#### 5.10.1. Directly Set

**Serial Number:** The serial number is loaded by the manufacturer and is displayed here (read-only).

**Product Name:** The product name entry area will be used to enter in the name of the product that the module will be upgraded to.

**Checksum:** The checksum location will contain the verification code that the Evertz sales department will provide when the options have been purchased.



**NOTE:** The Product name and the checksum NEED to be entered the exact same way as provided by the Evertz or the process will not work. These values are case sensitive.

#### 5.10.2. Script Set

**Script File:** When upgrading multiple 7800 cards a script file can be used to make the upgrade process easier. The required format of the script file is:

`<board serial number>,<current product string>,<new product string>,<checksum>`

If using a script file for upgrading the product string, follow these steps:

1. Browse to the location of the file on your computer
2. Press set to send the script file to the card

## 5.11. OUTPUT ROUTING

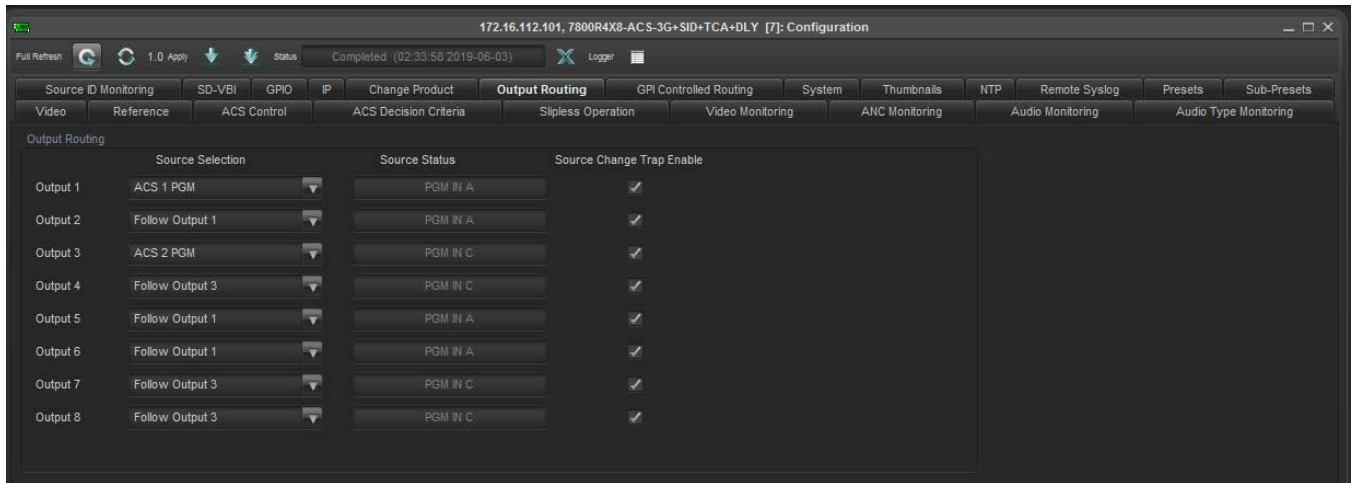

**Figure 5-21 : VistaLINK® PRO - Output Routing Section**

The 7800R4x8-ACS includes an output router that allows each output video path to be independently selected. The user is able to manually select an input, follow what is chosen by one of the Virtual Advanced Clean Switch Processors, follow the GPI Controlled Routing selection, or simply to follow one of the other physical outputs.



**NOTE:** The base 7800R4x8-ACS product only supports 2 independent outputs. If you require more output paths please contact the Evertz sales department for information on how to add the [+6OP] option.

In this case, the value for the Output Router Control for outputs 2, 5 and 6 is forced to “Follow Output 1” and the value for the Output Router Control for outputs 4, 7 and 8 are forced to “Follow Output 3”.

**Output <1-8> Source Selection:** This control selects the video source for the 8 physical SDI output paths. The options are:

- **PGM IN A:** Manually select PGM IN A as the source.
- **PGM IN B:** Manually select PGM IN B as the source.
- **PGM IN C:** Manually select PGM IN C as the source.
- **PGM IN D:** Manually select PGM IN D as the source.
- **ACS 1 PGM:** Automatically select the input video source that ACS Processor 1 chose for the Program path.
- **ACS 1 PRVW:** Automatically select the input video source that ACS Processor 1 chose for the Preview path.
- **ACS 2 PGM:** Automatically select the input video source that ACS Processor 2 chose for the Program path.
- **ACS 2 PRVW:** Automatically select the input video source that ACS Processor 2 chose for the Preview path.

- **GPI Controlled:** Automatically select the input video source determined by the current state of the GPIs as specified in the GPI Controlled Routing section.
- **Follow Output <1-8>:** Automatically follow whatever is selected for the physical output.

**Output <1-8> Source Status:** This read only control reports the physical input that is currently being routed to the corresponding physical output. The options are: PGM IN A, PGM IN B, PGM IN C and PGM IN D.

**Output <1-8> Source Change Trap:** This event trap will trigger whenever there is a change of the source for the corresponding physical output. The event trap includes binding information containing the new value of the Output <1-8> Source Status parameter. This is an event trap, and thus has no specific fault condition. Rather, it provides status information to the alarm server whenever a trigger event has occurred. To enable/disable the fault trap, check/uncheck the corresponding checkbox.



**Figure 5-22 : VistaLINK® PRO - Output Source Change Alarm**

Figure 5-22 shows an Output <1-8> Source Change Trap in the VLPro Alarm viewer. This trap is notifying the user of a source change for physical OUT 1 (acsOutVidPath=0) and that PGM IN B is now the source for this output.

## 5.12. GPI CONTROLLED ROUTING

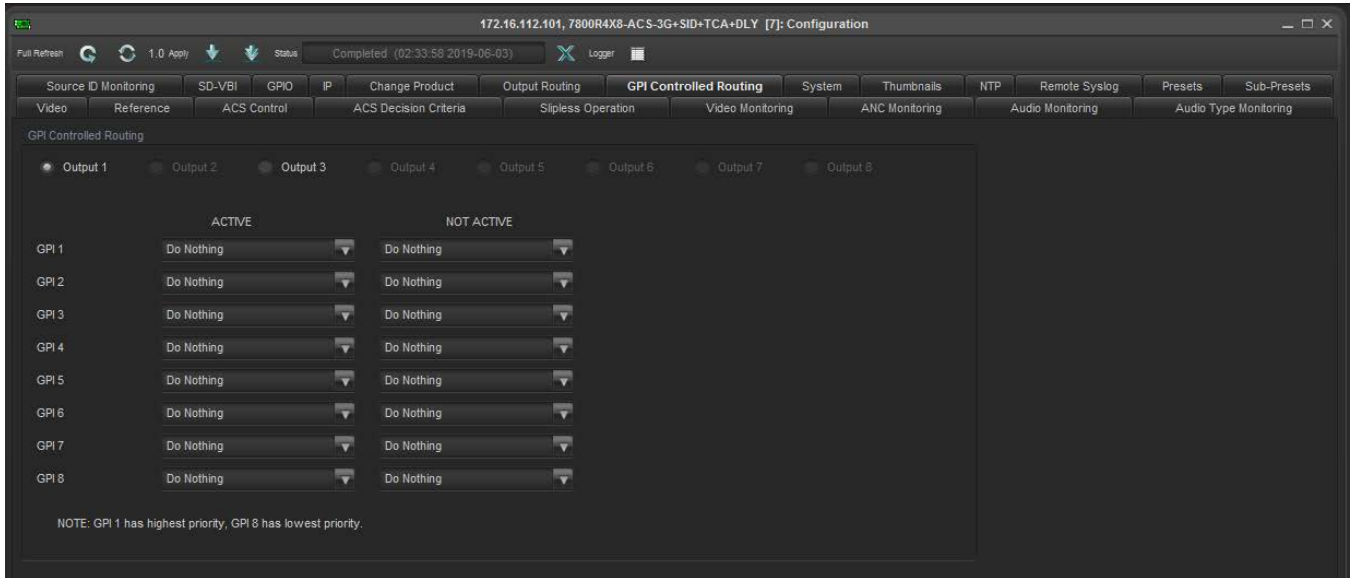

**Figure 5-23 : VistaLINK® PRO - GPI Controlled Routing Section**

The 7800R4x8-ACS product includes the ability to control the output video selection using GPIs. The GPI Controlled Routing section contains all of the controls required to determine how the GPIs choose what is routed to each output. It specifies the action that will occur when each GPI is ACTIVE as well as the action that will occur when each GPI is NOT ACTIVE for each video output.

The controls are presented as a table for each output. The radio buttons at the top of the section determine which video output's GPI Control is being configured. This allows each output video path to be controlled independently. The controls in the left column determine what action to take when the respective GPI is ACTIVE. The controls in the right column determine what action to take when the respective GPI is NOT ACTIVE. The choices are PGM IN A, PGM IN B, PGM IN C, PGM IN D, ACS 1 Program, ACS 2 Program, ACS 1 Preview, ACS 2 Preview and Do Nothing. When the action set for a GPI's current state is Do Nothing, the video source for that output will not be changed. In the case where the current state of multiple GPIs have actions associated with them, the priority rules apply. GPI 1 is the highest priority and GPI 8 is the lowest. A few examples may be helpful.

### ***GPI Controlled Routing Example 1:***

In this example we will use a toggle switch connected to GPI 1 to control the routing. When the switch is ON it activates the GPI, else the GPI is not active. When the switch is ON it will select PGM IN A. When the switch is OFF it will select PGM IN B.

<b>GPI #</b>	<b>Active Action</b>	<b>NOT Active Action</b>
1	PGM IN A	PGM IN B
2	Do Nothing	Do Nothing
3	Do Nothing	Do Nothing
4	Do Nothing	Do Nothing
5	Do Nothing	Do Nothing
6	Do Nothing	Do Nothing
7	Do Nothing	Do Nothing
8	Do Nothing	Do Nothing

**GPI Controlled Routing Example 2:**

In this example we will use 3 push buttons connected to the first 3 GPIs to control the routing. While the buttons are pressed, they activate their respective GPI, else the GPI is not active. When the user presses Button 1 it will select PGM IN A until another button is pressed. When the user presses Button 2 it will select PGM IN B until another button is pressed. When the user presses Button 3 it will begin to follow the source chosen for ACS PGM until another button is pressed.

GPI #	Active Action	NOT Active Action
1	PGM IN A	Do Nothing
2	PGM IN B	Do Nothing
3	ACS PGM	Do Nothing
4	Do Nothing	Do Nothing
5	Do Nothing	Do Nothing
6	Do Nothing	Do Nothing
7	Do Nothing	Do Nothing
8	Do Nothing	Do Nothing

**GPI Controlled Routing Example 3:**

In this example we will use 2 toggle switches connected to the first 2 GPIs to control the routing. While the 1<sup>st</sup> switch is ON it will select PGM IN A. If the 1<sup>st</sup> switch is OFF but the 2<sup>nd</sup> switch is ON it will select PGM IN B. When BOTH switches are OFF it will follow the source chosen for ACS PGM.

GPI #	Active Action	NOT Active Action
1	PGM IN A	Do Nothing
2	PGM IN B	ACS PGM
3	Do Nothing	Do Nothing
4	Do Nothing	Do Nothing
5	Do Nothing	Do Nothing
6	Do Nothing	Do Nothing
7	Do Nothing	Do Nothing
8	Do Nothing	Do Nothing

**5.13. SYSTEM**

The System section reports the status of the 7800R4x8-ACS system monitoring traps for temperature and fan operation. Figure 5-24 illustrates the layout of the controls in the VistaLINK<sup>®</sup> PRO configuration view.

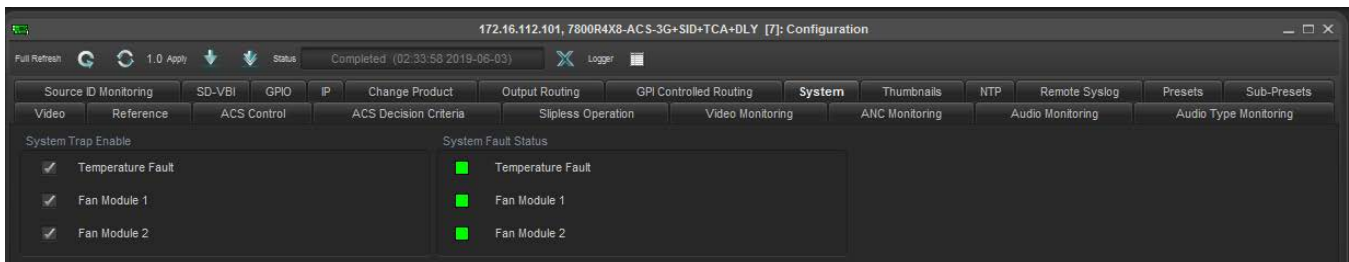

**Figure 5-24 : VistaLINK<sup>®</sup> PRO - System Section**

## System Fault Status

To enable/disable a specific fault trap, check/uncheck the corresponding checkbox.

**Temperature:** Triggers a FAULT trap when the module temperature exceeds 78°C.

**Fan Module <1-2>:** Triggers a FAULT trap when a fan failure is detected.

## 5.14. THUMBNAILS

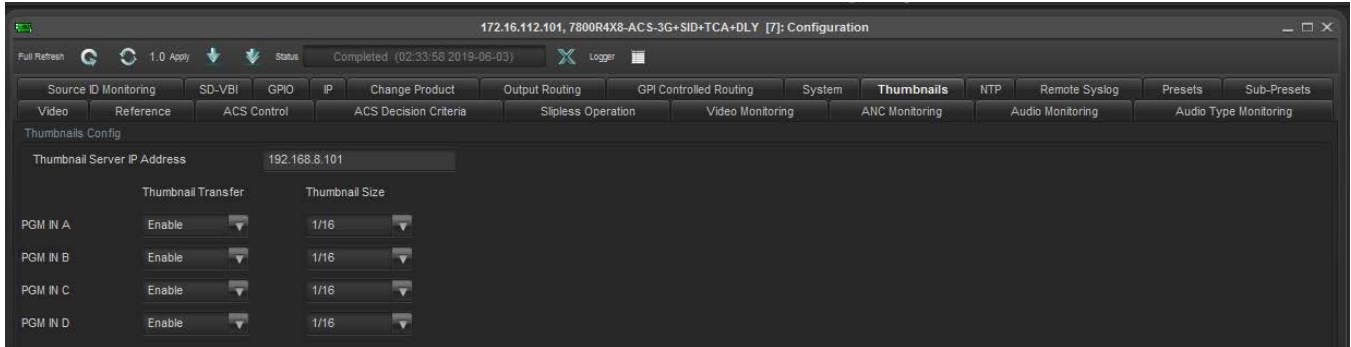

Figure 5-25 : VistaLINK® PRO – Thumbnails Section

### 5.14.1. Thumbnails Configuration

The 7800R4x8-ACS can be setup to work with the VistaLINK® thumbnail server in order to send video images of the output picture using the Simple Network Management Protocol (SNMP). The thumbnail images are generated after the input delay buffers and are therefore a representation of the video at the input to the output router. Each input has a set of independent controls that govern how the thumbnails are generated.

**Thumbnail Server IP Address:** This field allows the user to set the IP address of the thumbnail server.

**PGM IN <A,B,C,D> Thumbnail Transfer:** Allows the user to Enable/Disable the transfer of thumbnails for a particular input.

**PGM IN <A,B,C,D> Thumbnail Size:** Sets the size of the image sent to the VistaLINK® Thumbnail sever. The size is specified as a proportion of the original image size and can be either 1/32, 1/16, or 1/8 of the original video size.



**NOTE:** The number of thumbnail streams enabled and the size of the images directly influences the refresh rate. As the amount of data increases, the refresh rate decreases.

**5.15. NTP**

This section describes how to configure the module to connect with an NTP server. An NTP server can be used to set the local system time so that the time stamp of the log entries sent to a Remote Syslog Server are accurate.

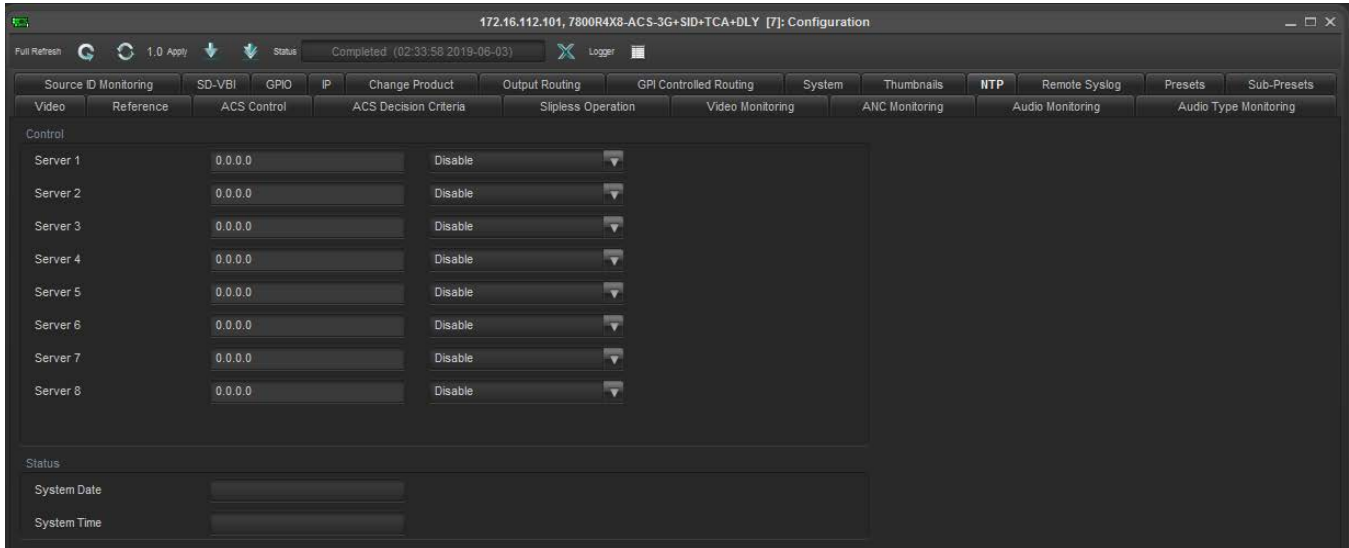

**Figure 5-26 : VistaLINK® PRO – NTP Section**

**Server <1-8> IP Address:** This field allows the user to set the IP address of a particular NTP server.

**Server <1-8> Enable:** This control allows the user to Enable/Disable a particular NTP server.

**System Date:** This status reports the current Date of the system. It can be used to verify that the NTP server settings are correct and that the module has properly synchronized the date.

**System Time:** This status reports the current Time of the system. It can be used to verify that the NTP server settings are correct and that the module has properly synchronized the time.

**5.16. REMOTE SYSLOG**

This section describes how to configure the module to connect with a Remote Syslog Server. A Remote Syslog server can be used to archive the module’s log entries and can assist with system level failure analysis.

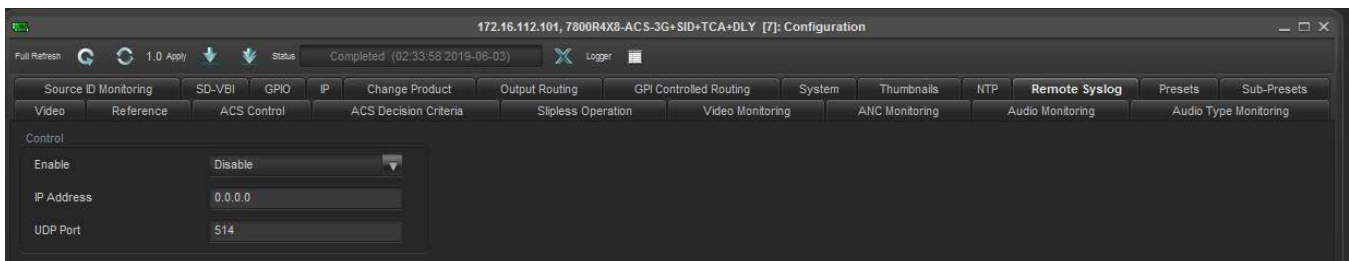

**Figure 5-27 : VistaLINK® PRO – Remote Syslog Section**

**Enable:** This control allows the user to Enable/Disable the connection with the Remote Syslog server.



**IP Address:** This field allows the user to set the IP address of the Remote Syslog server.

**UDP Port:** This field allows the user to set the UDP Port number of the Remote Syslog server.

### 5.17. PRESETS

The *Presets Control* section is used to load, store, trigger and name preset configurations. The module supports 10 user configurable presets that can be stored manually and recalled either manually or automatically using *GPI Preset Triggers*. Figure 5-28 illustrates the layout of the controls in the VistaLINK<sup>®</sup> PRO configuration view.

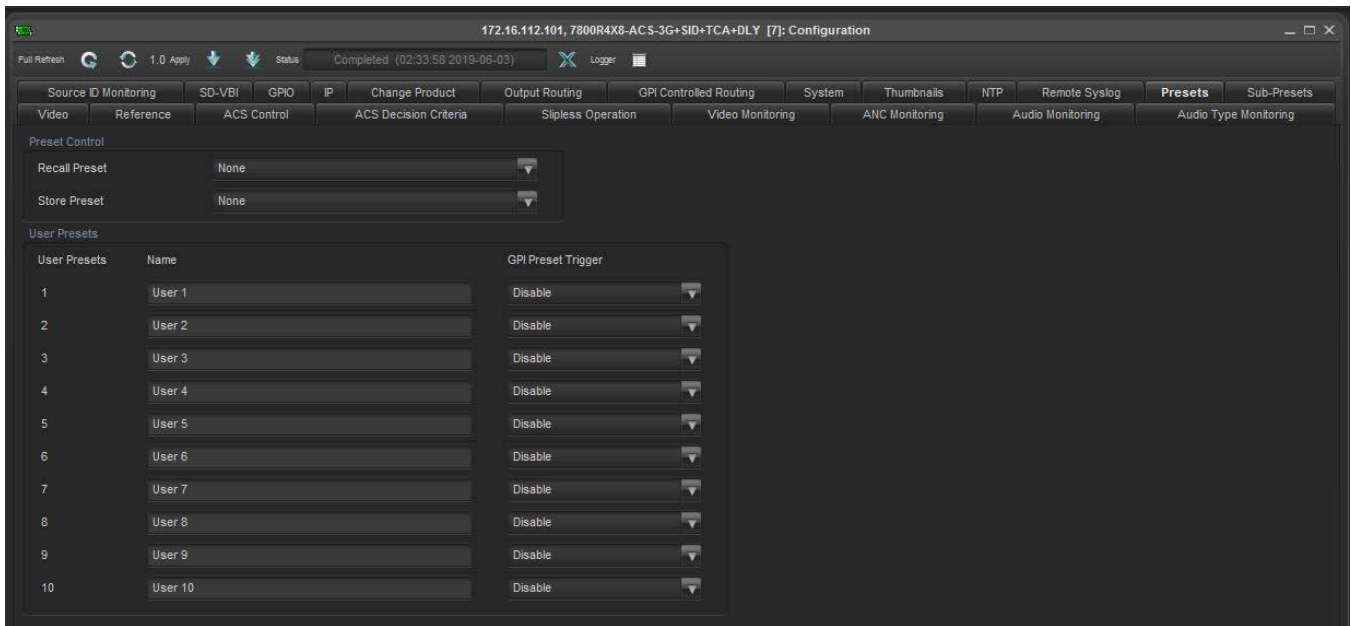

Figure 5-28 : VistaLINK<sup>®</sup> PRO - Presets Section

#### 5.17.1. Preset Control

**Recall Preset:** This control initiates a recall of a module configuration from one of the 10 available user presets, or resets the module to factory defaults by selecting to recall *Default*.

**Store Preset:** This control initiates a store of the current module's entire configuration into one of the 10 available user presets.



**NOTE:** The system does not support simultaneously recalling multiple presets. Each preset recall must be allowed to finish before another preset recall is initiated.

### 5.17.2. User Presets

**Name:** This control is used to provide a meaningful name to each user preset. For example, rather than simply using **User 1**, the user preset can take on a name such as **1080i/59.94 IN**. Once a name has been entered, the *Recall Preset* and *Store Preset* drop-down menus will be populated with the new name.



**NOTE:** The User Preset names are not stored inside the user presets. There is a single set of labels that are stored on each module.

**GPI Preset Trigger:** User presets can be automatically recalled using a GPI. Multiple GPIs can be used to trigger different module configurations in order to automatically support multiple modes of operation. This control allows the user to select which GPI will be used to recall each preset.



**NOTE:** A single GPI must not be used to recall multiple presets, nor can multiple GPIs be simultaneously activated to recall different presets.

### 5.18. SUB-PRESETS

Sub-presets provide the user the facility to load a subset of the module configuration controls into a user preset. In most cases, there is only a small subset of the system configurable parameters that need to be changed for a user's required modes of operation of the module. By loading a sub-preset, the system will only apply the preset value for the specified parameters within the sub-preset. This drastically reduces the system load, and significantly improves response time to a preset load. For these reasons, sub-presets are highly recommended over user presets which store all system configurable parameters.

A sub-preset configuration XML file must be first generated in VistaLINK® PRO. Once the XML configuration file has been generated, it can be loaded through the facilities of the Sub-Presets section. Figure 5-29 illustrates the layout of the controls in the VistaLINK® PRO configuration view.

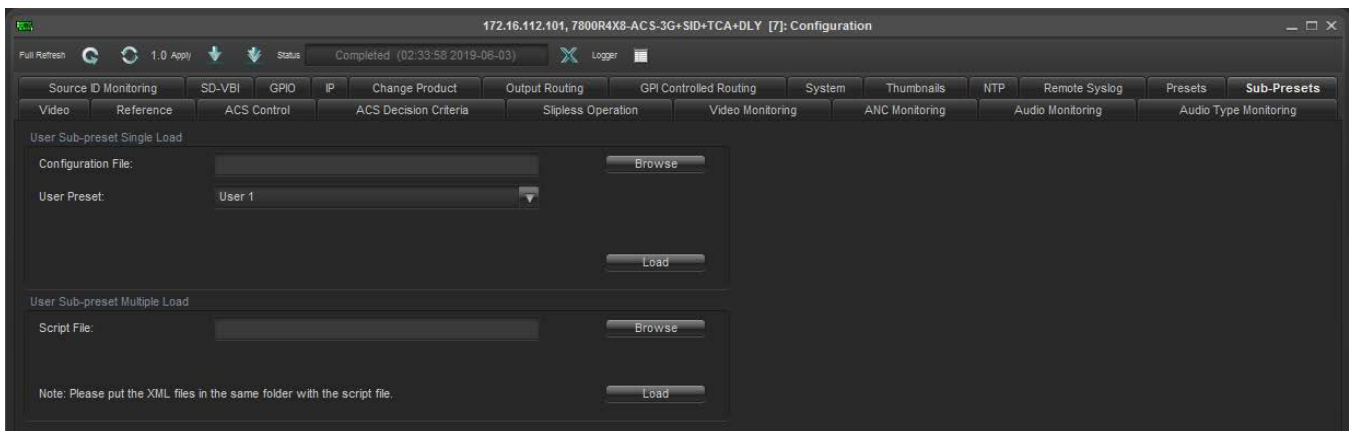

Figure 5-29 : VistaLINK® PRO - Sub-Presets Section

### 5.18.1. User Sub-preset Single Load

These controls provide the facilities to load a single sub-preset XML configuration file into a user preset.

**Configuration File:** By clicking the **Browse** button, the user can locate the sub-preset XML configuration file to be loaded.

**User Preset:** This control allows the user to specify which user preset to store the sub-preset configuration.

Once the proper **configuration file** has been selected, and the desired **user preset** to store the sub-preset configuration has been selected, click the **Load** button to load the sub-preset into the specified user preset.

### 5.18.2. User Sub-preset Multiple Load

These controls provide the facilities to perform multiple loads of sub-preset XML configuration files into user presets using scripts.



**NOTE:** The sub-preset loading script must be placed in the same directory as the sub-preset XML configuration files.

**Script File:** By clicking the **Browse** button, the user can locate the sub-preset loading script file to be executed.

Once the proper **script file** has been selected, click the **Load** button to load the multiple sub-presets into the specified user presets.

**Script File Format:** The script specifies exactly one sub-preset xml file per line. Each line in the sub-preset loading script must be as follows:

```
<name of sub-preset XML file>,<user preset #>
```

The following is an example sub-preset loading script that loads the contents of the file ref.xml into preset #1, anc.xml into preset #2 vid.xml into preset #3. All 4 files (the script, and the 3 xml files) must be in the same directory.

```
anc.xml,2  
vid.xml,3  
ref.xml,1
```



**NOTE:** There must be no space before or after the comma (,) in the script file. Also, any syntax errors in this process require the VL Pro Configuration view to be closed in order for the error to be cleared.

*This page is left intentionally blank*

## 6. WEB INTERFACE

### Login

After the card has been installed in a frame with a 7800FC or 7801FC, it can be completely configured using web interface. The 7800R4x8-ACS module's web interface is accessible through the Frame Controller. Simply type the Frame Controller's IP address into the web browser and then select the module of interest from the list.



**NOTE:** The Web interface is only supported in conjunction with a 7800FC or 7801FC. It will not function when using a 7700FC module as the frame controller.

**Note:** Computer must be on the same Subnet in order to have communication with the module.

Figure 6-1 : WebEASY® - Login Menu

Both the Login and Password is "customer".

On the FC Menu, click on the module to be configured. (Figure 6-2)

FC Menu				
Products				
Slot	Name	Family	Alias	Version
1	FC	Frame Controller		
2	7847FSE-3G+IG	7847FSE3GT		1.10.508
3	7847FS-EAES8-3G+IG+SCTE104IP	fseaes83g7847		1.5.129
4				
5	7800R2X2-ACS-3G+SID+TCA	7800R2X2ACS		7.15.964
6				
7	7800R4X8-ACS-3G+SID+TCA+DLY	7800R2X2ACS		6.13.926

**Figure 6-2 : WebEASY® - Frame Controller Menu**

On the web interface there are different types of menus as is shown in Figure 6-3.

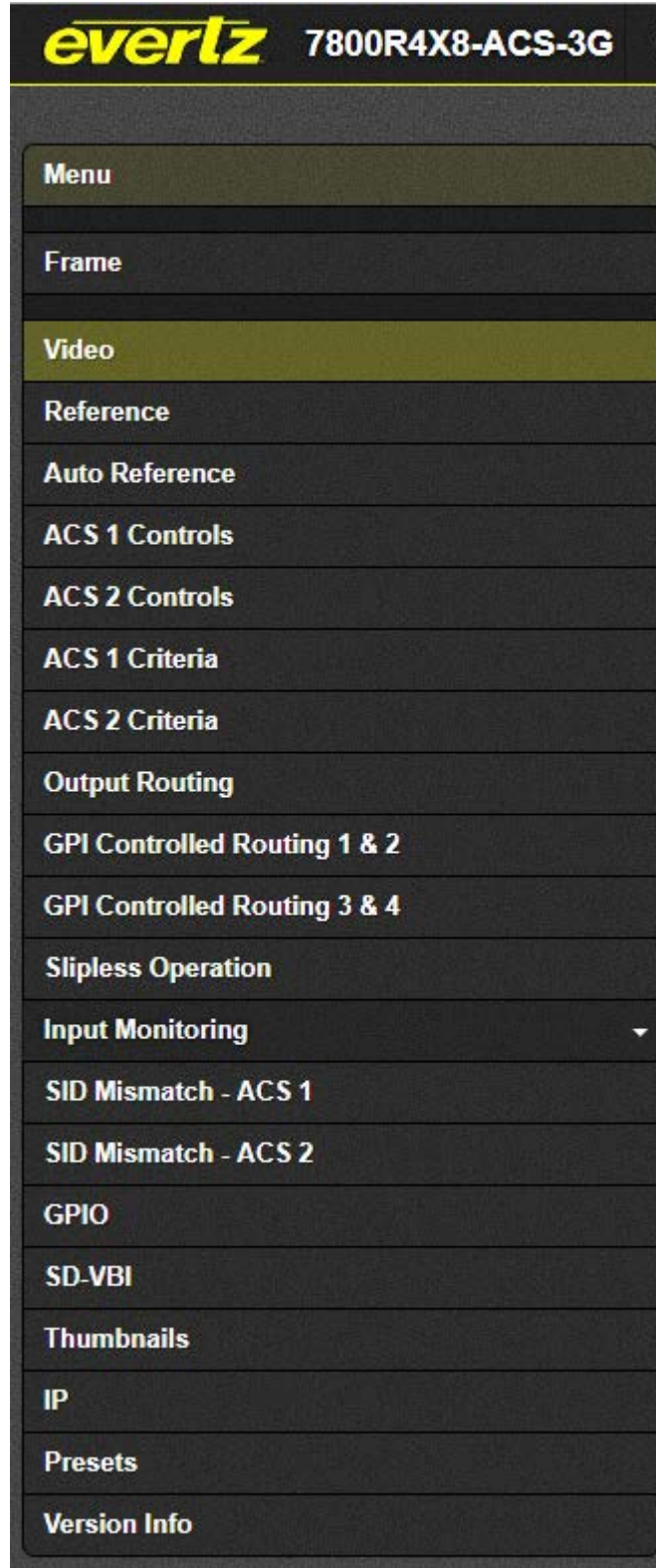

**Figure 6-3 : WebEASY<sup>®</sup> - 7800R4x8-ACS-3G Menu**

The functionality of the controls of each menu has been described in VistaLINK<sup>®</sup> PRO section (Section 5) of this manual.

*This page is left intentionally blank*



## 7. UPGRADE PROCEDURE

There are multiple components of the module operation that can be upgraded. These include:

- VistaLINK<sup>®</sup> PRO Product JAR upgrade
- Firmware upgrade
- Product String upgrade

This section outlines the procedures for performing these module upgrades.



**NOTE:** If multiple components require upgrading simultaneously (*For example: VistaLINK<sup>®</sup> PRO JAR and Firmware*), it is recommended the upgrades are performed in the order presented in this section.

### 7.1. VISTALINK<sup>®</sup> PRO UPGRADE PROCEDURE

Open VISTALINK<sup>®</sup> PRO Server and navigate to *Help > Apply Update > Product*. When the window opens you want to select the latest .jar file for the 7800R4x8-ACS, from its saved location on the computer and select **Open**.

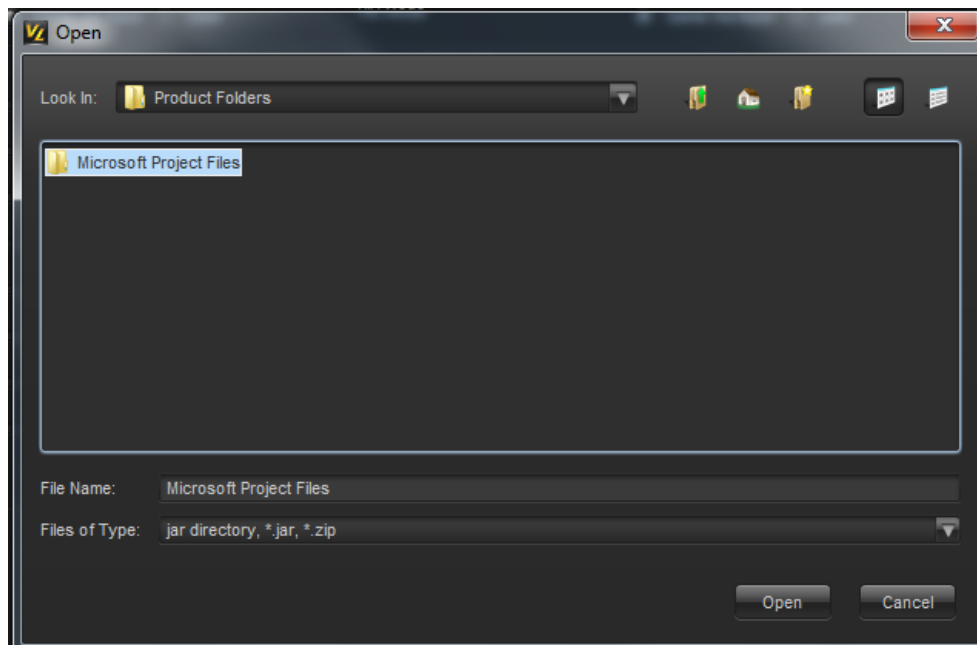

**Figure 7-1 : VistaLINK<sup>®</sup> PRO - Upgrade Window**

At this point the VistaLINK<sup>®</sup> PRO Server will send a message asking to Restart, select **Yes**. This will apply the 7800R4x8-ACS JAR update. Restart VISTALINK<sup>®</sup> PRO Server followed by VISTALINK<sup>®</sup> PRO Client.

When VISTALINK<sup>®</sup> PRO Client has re-opened, verify that VLPro is running the correct JAR version, to check this, simply right click on the cards address in VistaLINK<sup>®</sup> PRO Client and select **Version Information**.

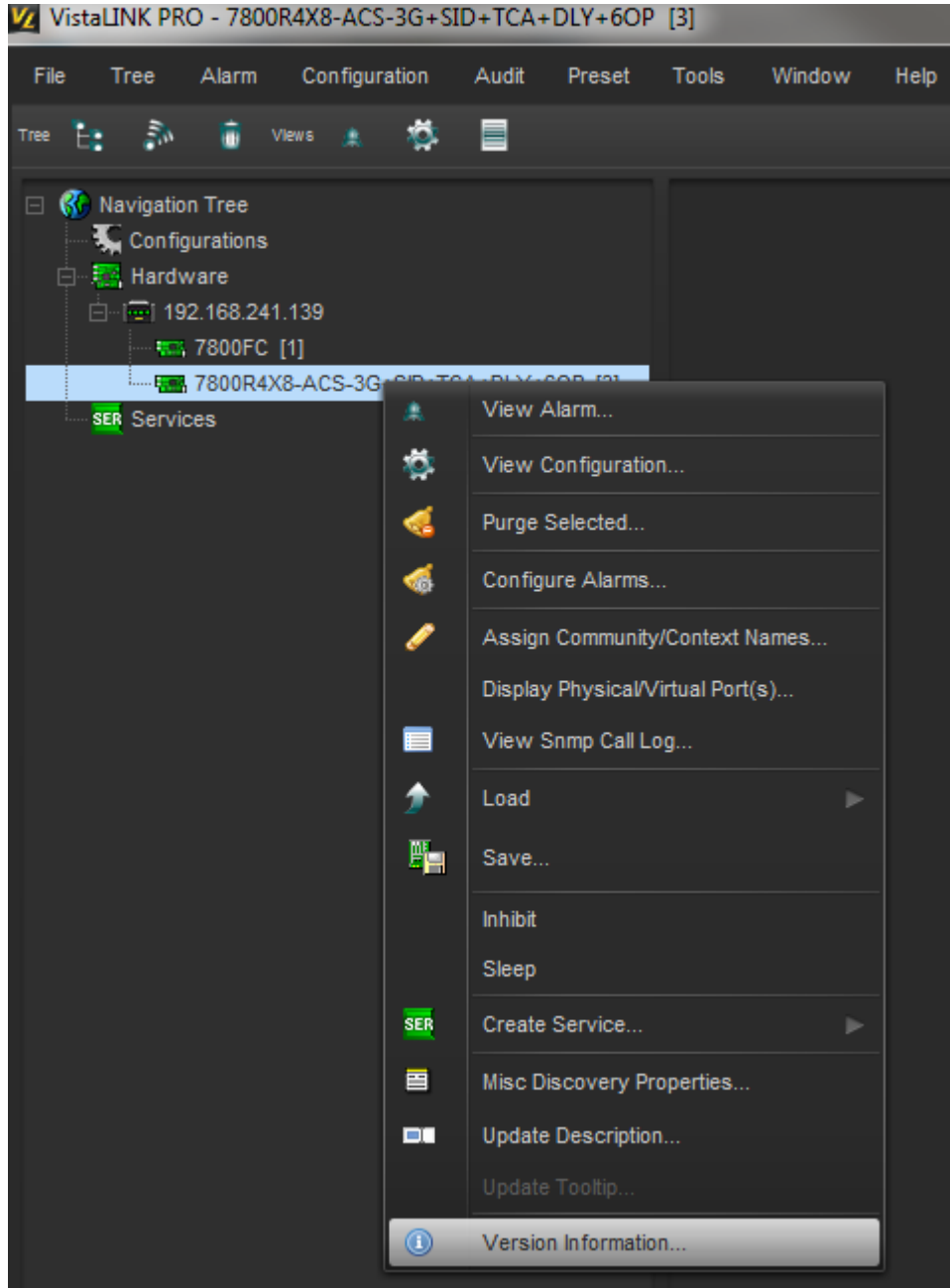

**Figure 7-2 : VistaLINK® PRO - Module Dropdown Menu**

This will open a window that displays all of the current version information loaded onto the 7800R4x8-ACS. Navigate the hardware tree on the left side of the version information window to select the 7800R4x8-ACS module. The *VISTALINK® PRO Product Version* reported in the top right corner of the window should match the new version. If it does not, please contact Evertz for further assistance.



**Figure 7-3 : VistaLINK® PRO - Version Information Section**

## 7.2. UPGRADE FIRMWARE

### 7.2.1. Firmware Upgrade Using VistaLINK® PRO

A firmware upgrade can be accomplished through VistaLINK® PRO firmware upgrade facilities. All 7800R4x8-ACS modules within the same 7700FR/7800FR frame can be upgraded simultaneously or one-by-one. However, it is more convenient to upgrade them simultaneously.

Right click on 7700FR/7800FR frame that contains the 7800R4x8-ACS modules, and select *Version Information*.

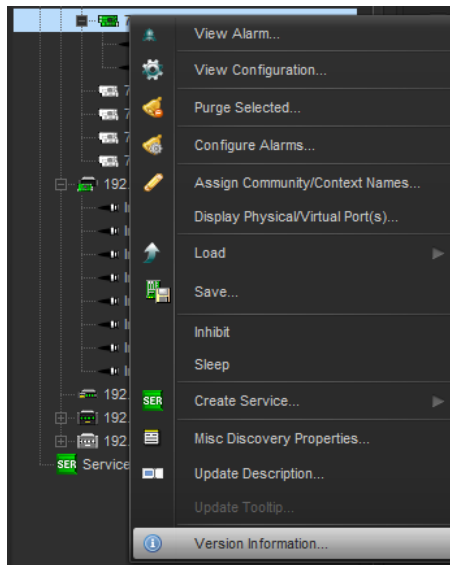

**Figure 7-4 : VistaLINK® PRO - Version information selection**

Navigate the hardware tree on the left side of the version information window to select the 7800R4x8-ACS module listed. The list on the right side of the window should populate with all 7800R4x8-ACS modules present in the 7700FR/7800FR. Take note of the current firmware version installed on the 7800R4x8-ACS modules to confirm afterwards that the upgrade has completed successfully.

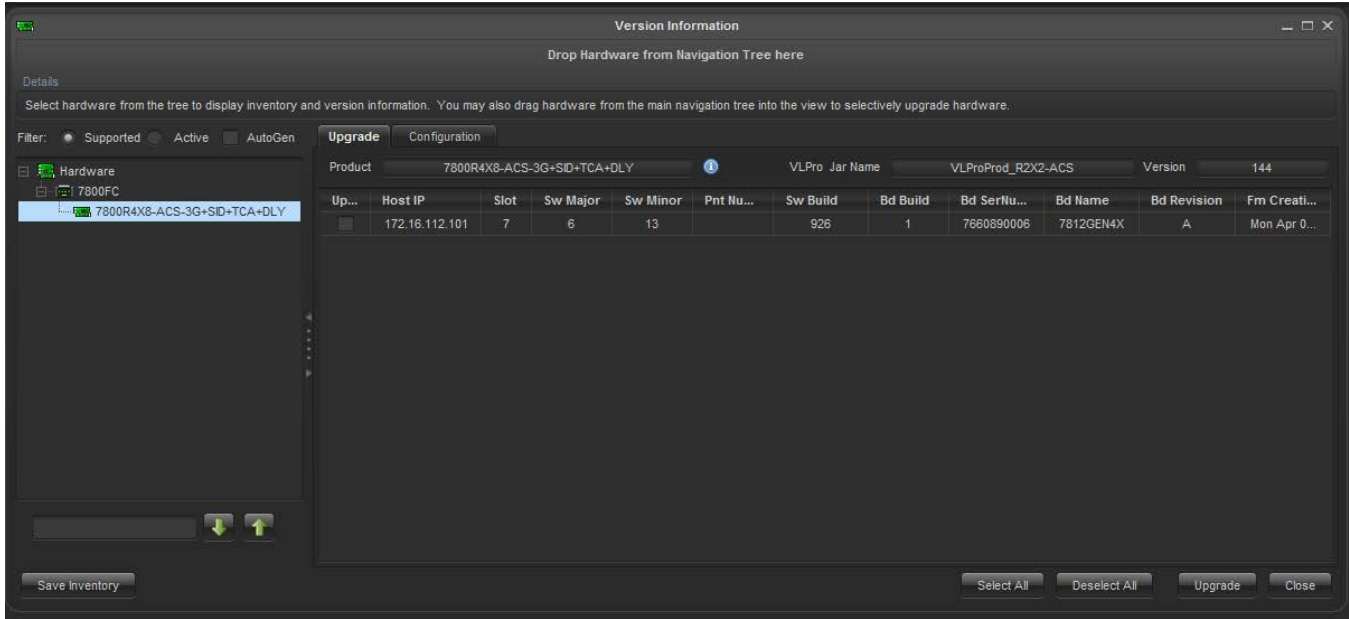

**Figure 7-5 : VistaLINK® PRO - Version Information Window**

Check the *Upgrade* checkbox for all modules that require the firmware upgrade. Press Upgrade button. This will open a new *Upgrade Firmware* window. Press the Browse button to navigate to the firmware archive provided for upgrading the 7800R4x8-ACS modules (**File extension is .tar.gz**). Once the correct file has been selected, press the *Start* button to begin the upgrade process.

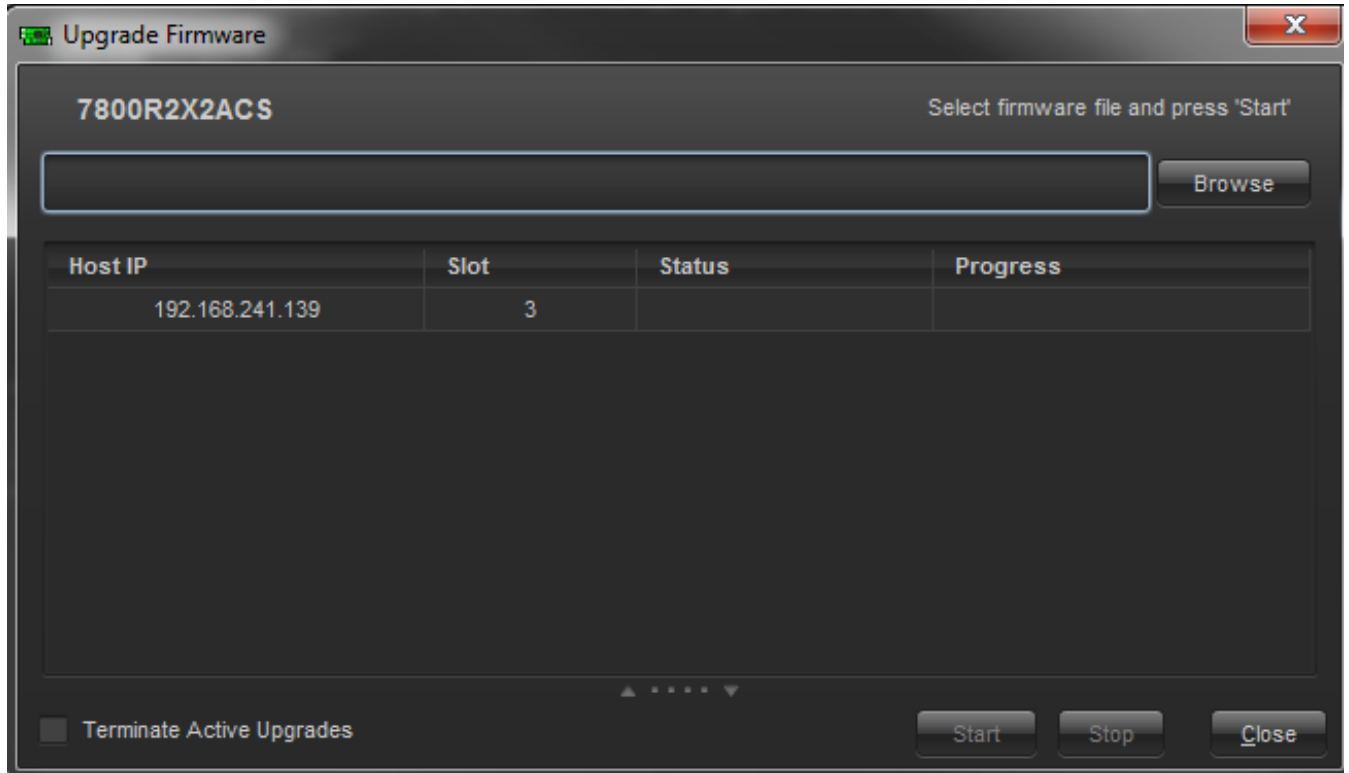

**Figure 7-6 : VistaLINK® PRO - Upgrade Firmware Window**

After the firmware has been transmitted to the 7800R4x8-ACS module successfully, the module will reboot to complete the firmware upgrade process. Close the *Upgrade Firmware* window and *Version Information* window.

Once the cards have rebooted, ensure all 7800R4x8-ACS modules are still present in the VistaLINK<sup>®</sup> PRO hardware tree. Right click on 7700FR/7800FR frame that contains the 7800R4x8-ACS modules, and select *Version Information*. Navigate the hardware tree on the left side of the version information window to select the 7800R4x8-ACS module listed. The list on the right side of the window should populate with all 7800R4x8-ACS modules present in the 7700FR/7800FR. Verify that all modules that have been upgraded are now reporting the expected firmware version.



**NOTE:** If any of the 7800R4x8-ACS modules do not properly upgrade the firmware, please power-cycle those boards and retry the procedure exclusively on the failed boards. If the issue still persists, contact Evertz for further assistance.

**7.2.2. Firmware Upgrade using WebEASY®**

Select the Upgrade section at the top of the general page.



**Figure 7-7 : WebEASY® - Selecting Upgrade**

Browse for the latest version of firmware to update with and select the Upgrade button. (Figure 7-8)

Firmware Upgrade					
Upgrade					
Firmware Upgrade					
Slot	Upgrade	Name	Alias	Current Version	Progress
1	Upgrade	Frame Controller			
2	<input type="checkbox"/>	7847FSE-3G+IG		1.10.508	<input type="text"/>
3	<input type="checkbox"/>	7847FS-EAES8-3G+IG+SCTE104IP		1.5.129	<input type="text"/>
4				0.0.0	<input type="text"/>
5	<input type="checkbox"/>	7800R2X2-ACS-3G+SID+TCA		7.15.964	<input type="text"/>
6				0.0.0	<input type="text"/>
7	<input type="checkbox"/>	7800R4X8-ACS-3G+SID+TCA+DLY		6.13.926	<input type="text"/>

**Figure 7-8 : WebEASY® - Firmware Upgrade Menu**

Upon completion, the 7800R4x8-ACS will reboot automatically and return online in normal “run” mode.

**7.3. UPGRADE PRODUCT STRING**

If a new product option has been purchased, it is necessary for the product options (*i.e. [-3G]*) to be included in the 7800R4x8-ACS module product string. Without the correctly updated product options, the 7800R4x8-ACS modules will not provide the additional functionality.

A unique checksum is required for each 7800R4x8-ACS module to upgrade the product string. These values must be entered correctly into VistaLINK® PRO to successfully update the product strings.



**NOTE:** Please contact Evertz to obtain the correct checksum values based on the reported 7800R4x8-ACS module serial numbers to be updated.

Each 7800R4x8-ACS module product string must be updated individually. To upgrade the 7800R4x8-ACS module product strings, open VistaLINK® PRO client, navigate to the desired 7800R4x8-ACS module in the hardware tree. Right click on the 7800R4x8-ACS module and select *View Configuration* to open the *module configuration* view:

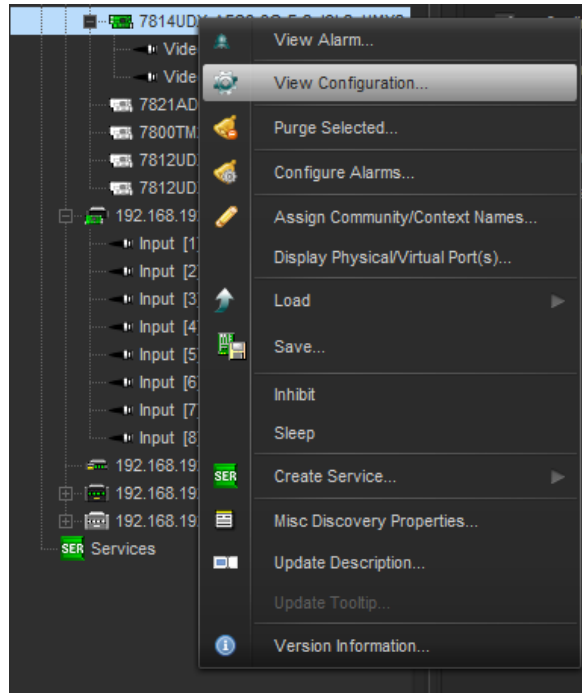

Figure 7-9 : VistaLINK® PRO - Opening 7800R4x8-ACS Module Configuration

Select the *Change Product* section (see Figure 7-10).

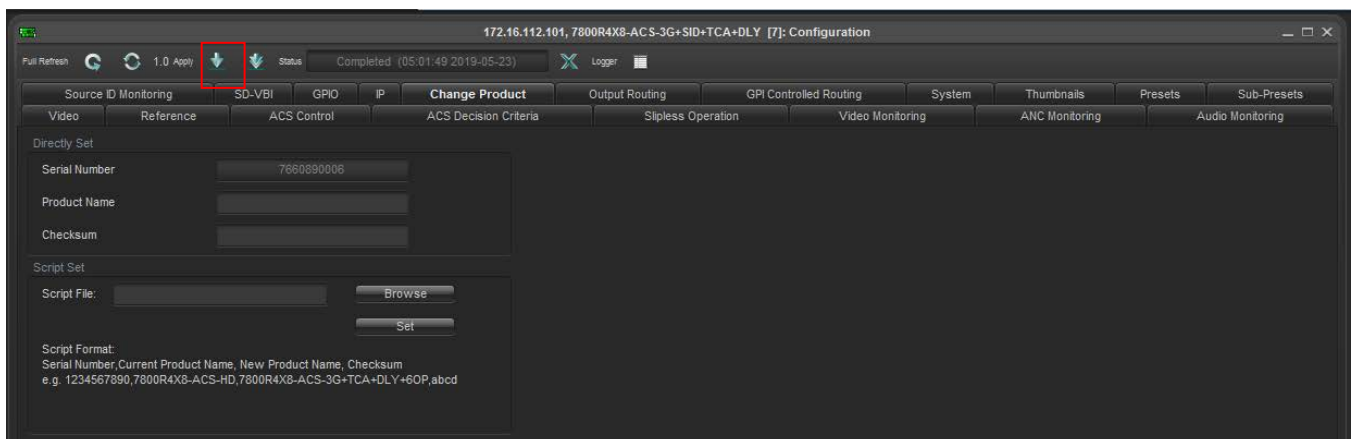

Figure 7-10 : VistaLINK® PRO - 7800R4x8-ACS module configuration view

Enter the **new product name** in the *Product Name* text box.



**NOTE:** Ensure the product name matches the product name specified with the provided checksum based on the 7800R4x8-ACS module serial number in the *Serial Number* textbox.

Enter the **checksum** in the *Checksum* text box.



**NOTE:** Ensure the checksum matches the checksum value specified according to the reported serial number in the *Serial Number* textbox.

Click the *Apply Button* (first blue arrow in top left of configuration view window) to update the 7800R4x8-ACS module product string (Figure 7-10). If the product string upgrade is successful, the product string specified in the VistaLINK<sup>®</sup> PRO hardware tree should update with the added product options. It can take approximately 5 minutes for the product string to update in VistaLINK<sup>®</sup> PRO.



**NOTE:** If any of the 7800R4x8-ACS modules do not properly upgrade the product string, please power-cycle those boards and retry the procedure exclusively on the failed boards. If the issue still persists, contact Evertz for further assistance.



## **8. APPENDIX A**

### **8.1. HARDWARE OPTIONS**

This manual covers the following hardware options:

- 7800R4x8-ACS-HD
- 7800R4x8-ACS-HD+BPRP
- 7800R4x8-ACS-HD+BPRP2
- 7800R4x8-ACS-HD+BPRP+HDBNC
- 7800R4x8-ACS-HD+BPRP2+HDBNC
- 7800R4x8-ACS-3G
- 7800R4x8-ACS-3G+BPRP
- 7800R4x8-ACS-3G+BPRP2
- 7800R4x8-ACS-3G+BPRP+HDBNC
- 7800R4x8-ACS-3G+BPRP2+HDBNC

### **8.2. VERSIONS**

This manual has been written using the following software versions. Functionality may not be identical to the manual description if the module is operating with a different firmware or VistaLINK<sup>®</sup> PRO product JAR versions.

- JAR File Version: 144
- Firmware Version: 6.13 build 926

*End of Document*