

TABLE OF CONTENTS

1.	OVERVIEW.....	1
2.	INSTALLATION.....	3
3.	SPECIFICATIONS.....	5
3.1.	SERIAL VIDEO INPUT	5
3.2.	SERIAL VIDEO OUTPUTS WITH EMBEDDED AUDIO	5
3.3.	AES AUDIO INPUTS	5
3.4.	SYSTEM PERFORMANCE	5
3.5.	ELECTRICAL	5
3.6.	PHYSICAL.....	6
4.	STATUS LEADS.....	7
4.1.	MODULE STATUS LEADS.....	7
4.2.	AUDIO GROUP AND MODE STATUS LEADS.....	7
5.	CARD EDGE CONTROLS	9
5.1.	SELECTING THE AUDIO GROUPS THAT WILL BE EMBEDDED.....	9
5.2.	SELECTING THE AUDIO DELAY	11
5.3.	SELECTING HOW EXISTING EMBEDDED AUDIO WILL BE HANDLED AND WHERE THE EMBEDDED AUDIO WILL BE PLACED	11
5.4.	SELECTING AES LOCKED GROUP MODE.....	12
5.5.	SELECTING SAMPLE RATE CONVERSION FOR AES INPUTS.....	13
5.6.	SELECTING FUNCTION OF THE MODULE OK STATUS LED.....	13
5.7.	SELECTING OPERATION WHEN THERE IS NO VIDEO INPUT.....	13
5.8.	SELECTING WHETHER THE MODULE WILL BE CONTROLLED FROM THE LOCAL CONTROLS OR THROUGH THE <i>VISTALINK</i> [®] INTERFACE	14
6.	JUMPERS.....	15
6.1.	SELECTING WHETHER LOCAL FAULTS WILL BE MONITORED BY THE GLOBAL FRAME STATUS	15
6.2.	CONFIGURING THE MODULE FOR FIRMWARE UPGRADES	15
7.	<i>VISTALINK</i> [®] REMOTE MONITORING/CONTROL.....	16
7.1.	WHAT IS <i>VISTALINK</i> [®] ?	16
7.2.	<i>VISTALINK</i> [®] MONITORED PARAMETERS	16
7.3.	<i>VISTALINK</i> [®] CONTROLLED PARAMETERS	17

7.4. VISTA LINK[®] TRAPS 17

Figures

Figure 1-1: 7721AE4-HD Block Diagram 2
Figure 2-1: Rear Panels 3
Figure 6-1: Location of Jumpers 15

Tables

Table 4-1: Audio Group and Mode Status LEDs 8
Table 5-1: Toggle Switch Function Overview 9
Table 5-2: Embedder 1 Enable Switch Settings 10
Table 5-3: Embedder 1 Group Switch Settings 10
Table 5-4: Embedder 2 Enable Switch Settings 10
Table 5-5: Embedder 2 Group Switch Settings 11
Table 5-6: Audio Delay Switch Settings 11
Table 5-7: HANC Handling Mode Switch Settings 11
Table 5-8: Lock Group Mode Switch Settings 12
Table 5-9: Sample Rate Conversion Switch Settings 13
Table 5-10: Module OK Status LED Switch Settings 13
Table 5-11: Loss of Video Mode Switch Settings 13
Table 5-12: VistaLINK[®] Control Switch Settings 14
Table 7-1: VistaLINK[®] Monitored Parameters 16
Table 7-2: VistaLINK[®] Controlled Parameters 17
Table 7-3: VistaLINK[®] Traps 17

REVISION HISTORY

<u>REVISION</u>	<u>DESCRIPTION</u>	<u>DATE</u>
1.0	First Release Version	Mar 04
1.1	Return loss specifications updated	Aug 04
1.2	Updated Group Lock control and added <i>VistaLINK</i> ® DIP switch information	Nov 05
1.3	Fixed format and updated <i>VistaLINK</i> ® description	Jun 08
1.4	Updated programmable audio delay spec	Jun 08
1.5	Added 7721AE4-B-HD rear plate drawing and information	Mar 09

Information contained in this manual is believed to be accurate and reliable. However, Evertz assumes no responsibility for the use thereof nor for the rights of third parties, which may be affected in any way by the use thereof. Any representations in this document concerning performance of Evertz products are for informational use only and are not warranties of future performance, either expressed or implied. The only warranty offered by Evertz in relation to this product is the Evertz standard limited warranty, stated in the sales contract or order confirmation form.

Although every attempt has been made to accurately describe the features, installation and operation of this product in this manual, no warranty is granted nor liability assumed in relation to any errors or omissions unless specifically undertaken in the Evertz sales contract or order confirmation. Information contained in this manual is periodically updated and changes will be incorporated into subsequent editions. If you encounter an error, please notify Evertz Customer Service department. Evertz reserves the right, without notice or liability, to make changes in equipment design or specifications.

This page left intentionally blank

1. OVERVIEW

The 7721AE4-HD Audio Embedder inserts AES audio signals into a 1.5Gb/s SDI video signal as specified in SMPTE 299M. The companion 7721AD4-HD Audio De-embedder facilitates audio demultiplexing at the destination.

SMPTE 299M allocates four groups of four audio channels that can be embedded into the SMPTE 292M bitstream. The 7721AE4-HD embeds up to 4 AES audio into two selectable groups on the SDI outputs for discrete 5.1 audio applications. The 7721AE4-HD is Dolby E compliant when the sample rate converters are turned off.

VistaLINK[®] enables control and configuration capabilities via Simple Network Management Protocol (SNMP). This offers the flexibility to manage the module status monitoring and configuration from SNMP enabled control systems such as Evertz *VistaLINK*[®] Pro locally or remotely.

Features:

- Automatic detection of video input format
- Bypass relay protection on one HD SDI output for power failures
- 24-bit AES input and audio embedding
- Individual audio group assignment for each group
- Group lock mode maintains phase relationship between the groups for 5.1 audio applications
- Sample rate conversion disabled on AES inputs to permit Dolby E embedding
- Programmable audio delays (up to 7 frames in ½ video field resolution) using DIP switches or (up to 1365.313 ms in 1 sample increments) via *VistaLINK*[®]
- Ancillary packet cleaning mode removes all audio before embedding
- Ancillary packet reformatting mode left justifies and removes unused packets before embedding
- Embeds audio on internally generated black or blue video when there is no video input
- *VistaLINK*[®] control capabilities for module configuration. *VistaLINK*[®] capabilities are available when modules are used with the 3RU 7700FR-C frame and a 7700FC *VistaLINK*[®] Frame Controller module in slot 1 of the frame
- Front panel LEDs indicate video and audio signal presence and module fault

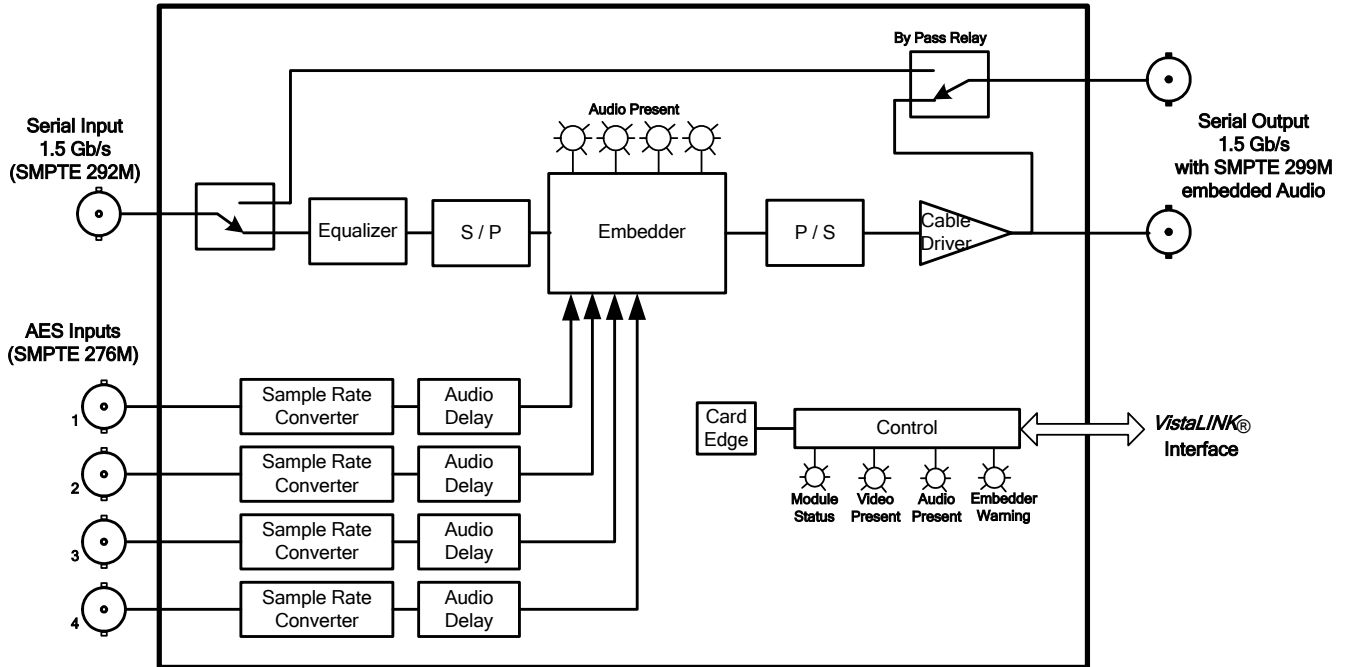

Figure 1-1: 7721AE4-HD Block Diagram

2. INSTALLATION

The 7721AE4-HD modules each come with a companion rear plate that has 7 BNC connectors. For information on mounting the rear plate and inserting the module into the frame see section 3 of the 7700FR chapter.

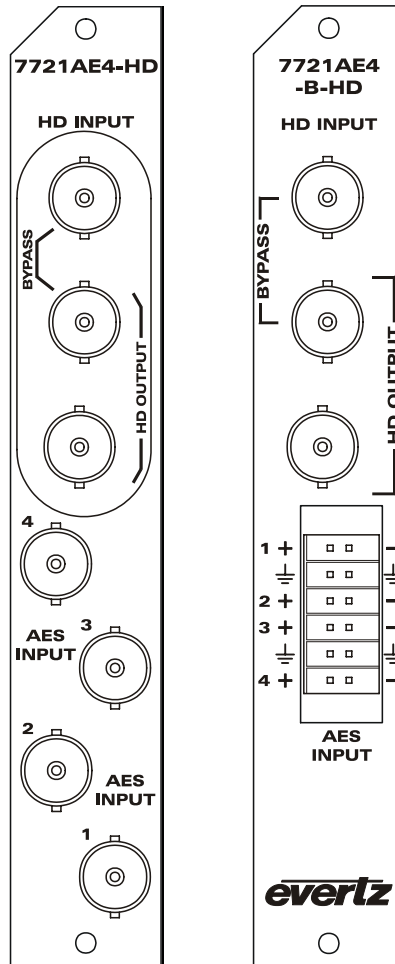

Figure 2-1: Rear Panels

HD INPUT: Input BNC connector for 10-bit serial digital video signals compatible with the SMPTE 292M standard.

HD OUTPUT: There are two BNC connectors with reclocked serial component video outputs, compatible with the SMPTE 292M standard. These outputs contain the input video with the audio present at AES inputs 1 to 4 embedded in accordance with the SMPTE 299M standard. On the 7721AE4-HD the top SDI output is protected by a bypass relay, which will activate in the event of power loss to the module. The remaining output is not bypass protected.

AES INPUT 1: AES audio input for AES pair 1 (channel 1 and 2) of the audio group selected for embedding by embedder 1.

AES INPUT 2: AES audio input for AES pair 2 (channel 3 and 4) of the audio group selected for embedding by embedder 1.

AES INPUT 3: AES audio input for AES pair 1 (channel 1 and 2) of the audio group selected for embedding by embedder 2.

AES INPUT 4: AES audio input for AES pair 2 (channel 3 and 4) of the audio group selected for embedding by embedder 2.

On the 7721AE4-B-HD, there is a 2 x 6 pin terminal strip containing the balanced AES input embedded from the video.

3. SPECIFICATIONS

3.1. SERIAL VIDEO INPUT

Standard: SMPTE 292M (1.5Gb/s),
1080i/60, 1080i/59.94, 1080i/50, 1080p/30sF, 1080p/29.97sF, 1080p/25sF,
1080p/24sF, 1080p/23.98sF, 720p/60, 720p/59.94, 720p/50)

Connector: BNC per IEC 61169-8 Annex A

Equalization: Automatic 100m @ 1.5 Gb/s with Belden 1694A or equivalent cable

Return Loss: > 10 dB up to 1.5 Gb/s

3.2. SERIAL VIDEO OUTPUTS WITH EMBEDDED AUDIO

Standard: Same as input

Number of Outputs: 2 (1 output bypass relay protected)

Embedded Audio: SMPTE 299M – 24 bit 48 kHz synchronous

Connectors: BNC per IEC 61169-8 Annex A

Signal Level: 800mV nominal

DC Offset: 0V ±0.5V

Rise and Fall Time: 200ps nominal

Overshoot: <10% of amplitude

Return Loss: > 10 dB up to 1.5 Gb/s

Wide Band Jitter: < 0.2 UI

3.3. AES AUDIO INPUTS

Number of Inputs: 4

Standard: SMPTE 276M, single ended AES

Connector: BNC per IEC 61169-8 Annex A

Resolution: 24 bits

Sampling Rate: 32 to 96 kHz synchronous or asynchronous
(48 kHz synchronous AES required when sample rate converter is disabled)

Impedance: 75 Ohms unbalanced

Signal Level: 1V p-p ±0.1V

3.4. SYSTEM PERFORMANCE

Embedding Latency: 1.3 to 3.0 msec

Audio Delay:

DIP Switch Control: up to 7 frames, ½ frame increments (delay applied to all AES channels)

VistaLINK[®] or Serial Port Control: up to 1365.313 ms in 1 sample increments (independent control of delay for each channel)

3.5. ELECTRICAL

Voltage: + 12VDC

Power: 11 Watts

EMI/RFI: Complies with FCC Part 15, class A and EU EMC directive

3.6. PHYSICAL

7700 or 7701 frame mounting:

Number of slots: 1

Stand Alone Enclosure:

Dimensions: 14 "L x 4.5 "W x 1.9 "H
(355 mm L x 114 mm W x 48 mm H)

Weight: approx. 1.5 lbs. (0.7 Kg)

4. STATUS LEDS

The location of the status LEDs is shown in Figure 6-1.

4.1. MODULE STATUS LEDS

MODULE OK: This Green LED will be On when the module is operating properly. Depending on the Status LED mode chosen, the LED will be On solid when input video or audio, or both video and audio, is present (please refer to section 5.6).

LOCAL FAULT: This Red LED makes it easy to identify one module in a frame that is missing an essential input or has another fault.

The LED will blink On and Off if the microprocessor is not running.

Depending on the Status LED mode chosen, the LED will be on solid when input video or audio is missing from all AES inputs, or both video and audio are missing. In addition, this LED will be On when there is a fault in the module power supply.

VIDEO PRESENT: This Green LED will be On when there is a valid video signal present at the module input.

AUDIO PRESENT: This Green LED will be On solid when there is a valid AES audio signal present at any of the AES inputs.

ERROR: This Yellow LED will be On when there are errors in the embedding process (for example, FIFO underflow).

4.2. AUDIO GROUP AND MODE STATUS LEDS

Four LEDs located on the lower end of the module (opposite the DIP switch) indicate the status of the audio groups when the DIP switches are all set to the OFF condition. LED 1 is located closest to the center of the module. When the DIP switches are set to other values, these LEDs are used to indicate various operational modes of the module (please refer to Table 4-1).

DIP Switch								Control Description	Value Description	LED			
	2	3	4	5	6	7	8			1	2	3	4
Off	Off	Off	Off	Off	Off	Off	---	Audio Present	AES1 Present	On			
									AES2 Present		On		
									AES3 Present			On	
									AES4 Present				On
On	Off	Off	Off	Off	Off	Off	---	Audio Delay	Minimum	Off	Off	Off	Off
									½ frame	On	Off	Off	Off
									1 frame	Off	On	Off	Off
									1 ½ frames	On	On	Off	Off
									2 frames	Off	Off	On	Off
									2 ½ frames	On	Off	On	Off
									3 frames	Off	On	On	Off
									3 ½ frames	On	On	On	Off
									4 frames	Off	Off	Off	On
									4 ½ frames	On	Off	Off	On
									5 frame	Off	On	Off	On
									5 ½ frames	On	On	Off	On
									6 frames	Off	Off	On	On
									6 ½ frames	On	Off	On	On
								7 frames	Off	On	On	On	
Off	On	Off	Off	Off	Off	Off	---	Embedder 1	Disable	Off	Off	Off	Off
									Enable	On	On	On	On
On	On	Off	Off	Off	Off	Off	---	Embedder 1 Group	Group 1	On	Off	Off	Off
									Group 2	Off	On	Off	Off
									Group 3	Off	Off	On	Off
									Group 4	Off	Off	Off	On
Off	Off	On	Off	Off	Off	Off	---	Embedder 2	Disable	Off	Off	Off	Off
									Enable	On	On	On	On
On	Off	On	Off	Off	Off	Off	---	Embedder 2 Group	Group 1	Off	Off	Off	Off
									Group 2	Off	On	Off	Off
									Group 3	Off	Off	On	Off
									Group 4	Off	Off	Off	On
Off	On	On	Off	Off	Off	Off	---	HANC Handling	Clean & embed	Off	Off	Off	Off
									Reformat and embed	On	On	On	On
On	On	On	Off	Off	Off	Off	---	Lock Groups	Independent Groups	Off	Off	Off	Off
									Locked Groups	On	On	On	On
Off	Off	Off	On	Off	Off	Off	---	Sample Rate Converter	Disable	Off	Off	Off	Off
									Enable	On	On	On	On
On	Off	Off	On	Off	Off	Off	---	Status LED Mode	Video Only	On	Off	Off	Off
									Audio Only	Off	On	Off	Off
									Video/ Audio	On	On	Off	Off
Off	On	Off	On	Off	Off	Off	---	Loss of Video Mode	Black	Off	Off	Off	Off
									Blue	On	On	On	On

Table 4-1: Audio Group and Mode Status LEDs

5. CARD EDGE CONTROLS

The 7721AE4-HD is equipped with an 8 position DIP switch to allow the user to select various functions. All positions are assigned sequentially such that the first position is located at the left side of the DIP switch (farthest from to the card ejector). When the switches are set to Off the LED status indicators near the DIP switch indicate the presence of the AES audio. When other DIP switch combinations are selected, various operation modes of the module can be set using the toggle switch. The LED Mode indicators near the DIP switch indicate the settings of each of these modes as shown in Table 4-1. The On position is down, or closest to the printed circuit board. Sections 5.1 to 5.8 show the assigned DIP switch functions.

DIP Switch								Control Description
1	2	3	4	5	6	7	8	
Off	Off	Off	Off	Off	Off	Off	Off	Audio Present
On	Off	Off	Off	Off	Off	Off	Off	Audio Delay
Off	On	Off	Off	Off	Off	Off	Off	Embedder 1 Enable
On	On	Off	Off	Off	Off	Off	Off	Embedder 1 Group
Off	Off	On	Off	Off	Off	Off	Off	Embedder 2 Enable
On	Off	On	Off	Off	Off	Off	Off	Embedder 2 Group
Off	On	On	Off	Off	Off	Off	Off	HANC Handling Mode
On	On	On	Off	Off	Off	Off	Off	Lock Groups
Off	Off	Off	On	Off	Off	Off	Off	Sample Rate Converter Mode
On	Off	Off	On	Off	Off	Off	Off	Status LED Mode
Off	On	Off	On	Off	Off	Off	Off	Loss of Video Mode
---	---	---	---	---	---	---	On	VistaLINK [®] or Remote Control

Table 5-1: Toggle Switch Function Overview

5.1. SELECTING THE AUDIO GROUPS THAT WILL BE EMBEDDED

The SMPTE 299M standard permits up to 4 groups of 4 audio channels to be embedded into the 270 Mb/s video bitstream. Model 7721AE4-HD has two separate embedders that will embed up to four audio channels (two AES pairs) into one of the groups. The Embedders can be treated as two independent embedders for unrelated audio content or can be locked together where the audio in both groups is related and hence its phase must be maintained (for example, 5.1 surround sound audio).



Some legacy equipment may not be compatible with two embedded audio groups present in the video stream.

The source for Embedder A is the audio coming in on the AES IN 1 and 2 connectors. The source for Embedder B is the audio coming in on the AES IN 3 and 4 connectors. There are separate DIP switch settings that are used to enable or disable each embedder as well as to set the audio groups where the embedders will place the audio on the SDI output.

When the DIP switches are set as shown in Table 5-2, the toggle switch is used to enable or disable Embedder 1. Each time the toggle switch is pressed up or down the Embedder 1 Enable mode will change as indicated by the LEDs in Table 5-2.

When set to *Disable*, embedder 1 will be disabled. When set to *Enable*, the embedder destination can be set when the DIP switches are set as shown in Table 5-3. Channels 1 and 2 from AES input 1 will be embedded into channels 1 and 2 of the selected group. Channels 1 and 2 from AES input 2 will be embedded into channels 3 and 4 of the selected group. If audio is not present on one or both of the AES inputs, the respective channels of the selected audio group will be mute.

DIP Switch								Control Description	Value Description	LED			
1	2	3	4	5	6	7	8			1	2	3	4
Off	On	Off	Off	Off	Off	Off	Off	Embedder 1	Disable	Off	Off	Off	Off
									Enable	On	On	On	On

Table 5-2: Embedder 1 Enable Switch Settings

DIP Switch								Control Description	Value Description	LED			
1	2	3	4	5	6	7	8			1	2	3	4
On	On	Off	Off	Off	Off	Off	Off	Embedder 1 Group	Group 1	On	Off	Off	Off
									Group 2	Off	On	Off	Off
									Group 3	Off	Off	On	Off
									Group 4	Off	Off	Off	On

Table 5-3: Embedder 1 Group Switch Settings

When the DIP switches are set as shown in Table 5-4, the toggle switch is used to enable or disable Embedder 2. Each time the toggle switch is pressed up or down the Embedder 2 Enable mode will change as indicated by the LEDs in Table 5-4.

When set to *Disable*, embedder 2 will be disabled. When set to *Enable*, the embedder destination can be set when the DIP switches are set as shown in Table 5-5. Channels 1 and 2 from AES input 3 will be embedded into channels 1 and 2 of the selected group. Channels 1 and 2 from AES input 4 will be embedded into channels 3 and 4 of the selected group. If audio is not present on one or both of the AES inputs, the respective channels of the selected audio group will be mute.

DIP Switch								Control Description	Value Description	LED			
1	2	3	4	5	6	7	8			1	2	3	4
Off	Off	On	Off	Off	Off	Off	Off	Embedder 2	Disable	Off	Off	Off	Off
									Enable	On	On	On	On

Table 5-4: Embedder 2 Enable Switch Settings

DIP Switch								Control Description	Value Description	LED			
1	2	3	4	5	6	7	8			1	2	3	4
On	Off	On	Off	Off	Off	Off	Off	Embedder 2 Group	Group 1	On	Off	Off	Off
									Group 2	Off	On	Off	Off
									Group 3	Off	Off	On	Off
									Group 4	Off	Off	Off	On

Table 5-5: Embedder 2 Group Switch Settings

5.2. SELECTING THE AUDIO DELAY

When the DIP switches are as shown in Table 5-6, the toggle switch is used to select one of fifteen delays which can be added to the audio before it is embedded. This delay allows the user to resynchronize the audio back to the video to accommodate video processing delays. The delay is applied to all AES channels prior to embedding.

DIP Switch								Control Description	Value Description	LED			
1	2	3	4	5	6	7	8			1	2	3	4
On	Off	Off	Off	Off	Off	Off	Off	Audio Delay	Minimum	Off	Off	Off	Off
									½ frame	On	Off	Off	Off
									1 frame	Off	On	Off	Off
									1 ½ frames	On	On	Off	Off
									2 frames	Off	Off	On	Off
									2 ½ frames	On	Off	On	Off
									3 frames	Off	On	On	Off
									3 ½ frames	On	On	On	Off
									4 frames	Off	Off	Off	On
									4 ½ frames	On	Off	Off	On
									5 frame	Off	On	Off	On
									5 ½ frames	On	On	Off	On
									6 frames	Off	Off	On	On
									6 ½ frames	On	Off	On	On
									7 frames	Off	On	On	On

Table 5-6: Audio Delay Switch Settings

5.3. SELECTING HOW EXISTING EMBEDDED AUDIO WILL BE HANDLED AND WHERE THE EMBEDDED AUDIO WILL BE PLACED

When the DIP switches are set as shown in Table 5-7, the toggle switch is used to select how existing HANC packets will be handled by the embedder.

DIP Switch								Control Description	Value Description	LED			
1	2	3	4	5	6	7	8			1	2	3	4
Off	On	On	Off	Off	Off	Off	Off	HANC Handling	Clean & embed	Off	Off	Off	Off
									Reformat and embed	On	On	On	On

Table 5-7: HANC Handling Mode Switch Settings

When *Clean and embed* is selected, all incoming HANC packets and embedded audio data will be removed; and new audio data will be embedded after EAV. The remaining H blanking period is filled with default blanking value.

When *Reformat and embed* is selected, pre-existing embedded audio contents will be extracted. All packets with "Marked Packet for Deletion" or containing the same selected audio groups that are selected for embedding will be removed. The remaining packets are left justified and new audio will be embedded after these packets.

5.4. SELECTING AES LOCKED GROUP MODE

For audio that is synchronous to video there is exactly 8008 audio samples (48kHz sampling rate) in 5 frames of NTSC, 525 line video. Most audio embedders will spread these samples as evenly as possible throughout the 5 frames of video. Because the 8008 samples do not divide evenly into 5 frames of video, there is a sequence that only repeats every 5 frames. In all video standards it is possible for the phase of the audio being embedded by two separate embedders to be out of phase with respect to each other. In order to transport 8 channels of audio (4 AES pairs) through an embedded link with exactly the same delay on each channel, both the embedder and the de-embedder must lock the FIFOs of both groups of audio together. Failing to do so will cause a phase difference between the audio from the two groups.

When the DIP switches are set as shown in Table 5-8, the toggle switch is used to select whether the embedders will be operated separately or locked together for embedding related audio (such as 5.1 surround sound).

DIP Switch								Control Description	Value Description	LED			
1	2	3	4	5	6	7	8			1	2	3	4
On	On	On	Off	Off	Off	Off	Off	Lock Groups	Independent Groups	Off	Off	Off	Off
									Locked Groups	On	On	On	On

Table 5-8: Lock Group Mode Switch Settings

When *Independent group* mode is selected, Embedder 1 and Embedder 2 are operated independently of each other as if two separate embedder devices are being used. The FIFOs are not locked together and the output phases of the two groups of embedded audio do not have any specific relationship to each other.

When *Locked group* mode is selected, the Embedder FIFOs are locked together maintaining the phase relationship between all 4 AES channel pairs in the embedded audio.



To maintain a guaranteed audio phase relationship through a complete SDI link, the audio de-embedder MUST also provide the same locked FIFO management functionality.



For firmware releases 2.3 build 3 and newer, *Locked Group* mode is ALWAYS active regardless of the DIP switch setting. Changing the settings will have NO effect on the mode.

5.5. SELECTING SAMPLE RATE CONVERSION FOR AES INPUTS

When the DIP switches are as shown in Table 5-9, the toggle switch is used to select whether the sample rate conversion for the AES inputs is enabled or not.

DIP Switch								Control Description	Value Description	LED			
1	2	3	4	5	6	7	8			1	2	3	4
Off	Off	Off	On	Off	Off	Off	Off	Sample Rate Converter	Disable	Off	Off	Off	Off
									Enable	On	On	On	On

Table 5-9: Sample Rate Conversion Switch Settings

When the Sample Rate converters are *Enabled*, the AES inputs are sample rate converted at 48 kHz which is synchronous to the input video. AES inputs can be either synchronous or asynchronous to the video source.

When the Sample Rate converters are *Disabled*, the content of AES inputs is preserved without any loss, and directly embedded into the input video. AES inputs must be synchronous to the video source. This setting is required when embedding Dolby E.

5.6. SELECTING FUNCTION OF THE MODULE OK STATUS LED

When the DIP switches are set as shown in Table 5-10, the toggle switch is used to select the function of the Module OK LED status indicator (please refer to section 4.1).

DIP Switch								Control Description	Value Description	LED			
1	2	3	4	5	6	7	8			1	2	3	4
On	Off	Off	On	Off	Off	Off	Off	Status LED Mode	Video Only	On	Off	Off	Off
									Audio Only	Off	On	Off	Off
									Video/ Audio	On	On	Off	Off

Table 5-10: Module OK Status LED Switch Settings

In the *Video only* mode the Module OK status LED will be On when there is video present.

In the *Audio only* mode the Module OK status LED will be On when there is audio present on at least one of the AES inputs.

In the *Video and Audio* mode the Module OK status LED will be On when there is video present and there is audio present on at least one of the AES inputs.

5.7. SELECTING OPERATION WHEN THERE IS NO VIDEO INPUT

When there is no input video, the 7721AE4-HD will generate its own video and embed the audio onto it. When the DIP switches are set as shown in Table 5-11, the toggle switch is used to select whether the module will generate black or blue video.

DIP Switch								Control Description	Value Description	LED			
1	2	3	4	5	6	7	8			1	2	3	4
Off	On	Off	On	Off	Off	Off	Off	Loss of Video Mode	Black	Off	Off	Off	Off
									Blue	On	On	On	On

Table 5-11: Loss of Video Mode Switch Settings

5.8. SELECTING WHETHER THE MODULE WILL BE CONTROLLED FROM THE LOCAL CONTROLS OR THROUGH THE VISTA LINK[®] INTERFACE

DIP switch 8 selects whether the module will be controlled from the local user controls or through the VistaLINK[®] interface.

DIP Switch								Control Description	Value Description	LED			
1	2	3	4	5	6	7	8			1	2	3	4
							On	VistaLINK [®] or Remote Control					

Table 5-12: VistaLINK[®] Control Switch Settings

When the DIP switch 8 is turned Off, the card functions are controlled through the card edge controls (for example, DIP switches).

When the DIP switch 8 is turned On, the card functions are controlled through the VistaLINK[®] interface (please refer to section 7) and the card edge controls (for example, DIP switches).

6. JUMPERS

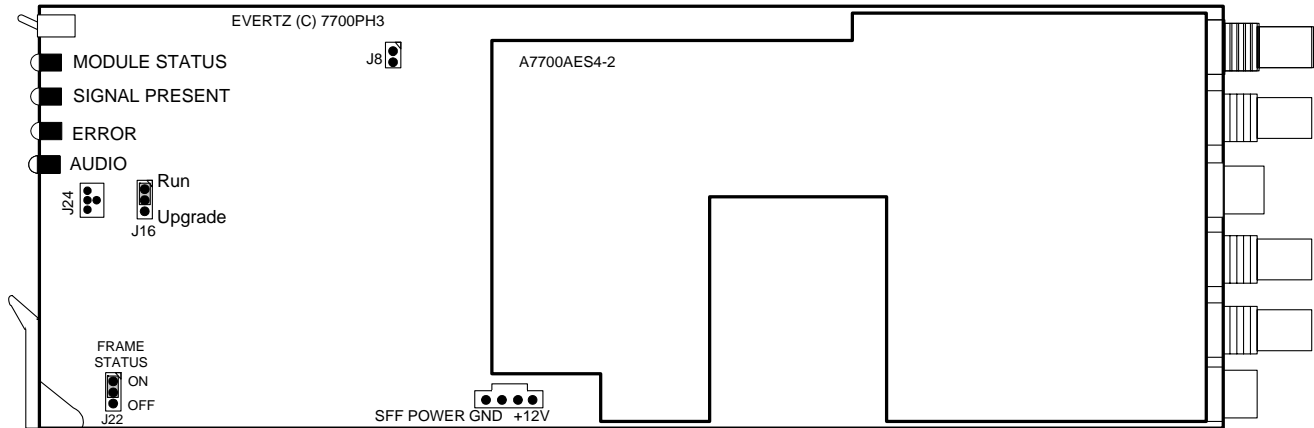

Figure 6-1: Location of Jumpers

6.1. SELECTING WHETHER LOCAL FAULTS WILL BE MONITORED BY THE GLOBAL FRAME STATUS

FRAME STATUS: The FRAME STATUS jumper located at the front of the module determines whether local faults (as shown by the Local Fault indicator) will be connected to the 7700FR frame's global status bus.

To monitor faults on this module with the frame status indicators (on the Power Supply FRAME STATUS LED's and on the Frame's Fault Tally output) install this jumper in the On position. (Default)

When this jumper is installed in the Off position, local faults on this module will not be monitored.

6.2. CONFIGURING THE MODULE FOR FIRMWARE UPGRADES

UPGRADE: The UPGRADE jumper J16 located at the front of the module is used when firmware upgrades are being done to the module. For normal operation it should be installed in the *RUN* position. See the *Upgrading Firmware* chapter in the front of the binder for more information.

To upgrade the firmware in the module unit pull it out of the frame. Move Jumper J16 into the *UPGRADE* position. Install the Upgrade cable provided (located in the vinyl pouch in the front of this manual) onto header J24 at the card edge. Re-install the module into the frame. Run the upgrade as described in *Upgrading Firmware* chapter in the front of the binder. Once the upgrade is complete, remove the module from the frame, move J16 into the *RUN* position, remove the upgrade cable and re-install the module. The module is now ready for normal operation.

7. VistaLINK® REMOTE MONITORING/CONTROL

7.1. WHAT IS VISTALINK®?

VistaLINK® is Evertz's remote monitoring and configuration platform which operates over an Ethernet network using Simple Network Management Protocol (SNMP). SNMP is a standard computer network protocol that enables different devices sharing the same network to communicate with each other. VistaLINK® provides centralized alarm management, which monitors, reports, and logs all incoming alarm events and dispatches alerts to all the VLPro Clients connected to the server. Card configuration through VistaLINK® PRO can be performed on an individual or multi-card basis using simple copy and paste routines, which reduces the time to configure each module separately. Finally, VistaLINK® enables the user to configure devices in the network from a central station and receive feedback that the configuration has been carried out.

There are 3 components of SNMP:

1. An SNMP manager, also known as a Network Management System (NMS), is a computer running special software that communicates with the devices in the network. Evertz VL-Fiber demo Manager graphical user interface (GUI), third party or custom manager software may be used to monitor and control Evertz VistaLINK® enabled fiber optic products.
2. Managed devices, (such as 7721AE4-HD), each with a unique address (OID), communicate with the NMS through an SNMP Agent. Evertz VistaLINK® enabled 7700 series modules reside in the 3RU 7700FR-C MultiFrame and communicate with the manager via the 7700FC VistaLINK® frame controller module, which serves as the Agent.
3. A virtual database, known as the Management information Base (MIB), lists all the variables being monitored, which both the Manager and Agent understand. Please contact Evertz for further information about obtaining a copy of the MIB for interfacing to a third party Manager/NMS.

For more information on connecting and configuring the VistaLINK® network, see the 7700FC Frame Controller chapter.

7.2. VISTALINK® MONITORED PARAMETERS

The following parameters can be remotely monitored through the VistaLINK® interface:

Parameter	Description
Input Signal Present	Indicates the presence of a valid video and audio input signal (the state of the VIDEO and AUDIO present LEDs).
Local Mode	Indicates whether the Embedder module is under VistaLINK® or local control.

Table 7-1: VistaLINK® Monitored Parameters

7.3. VISTALINK[®] CONTROLLED PARAMETERS

Parameter	Description
AES Delay	Sets the delay applied to the AES inputs before embedding
Audio Embedder 1 Enable	Enables/Disables embedder 1
Audio Embedder 1 Group	Sets destination group for embedder 1
Audio Embedder 2 Group	Enables/Disables embedder 2
Audio Embedder 2 Group	Sets destination group for embedder 2
HANC Mode	Sets whether the HANC space will be cleaned or reformatted
Group Lock Mode	Sets Group Lock mode
SRC Enable	Enables/Disables the Sample Rate Converters
LOV Mode	Controls if there will be black or blue video on Loss of Input

Table 7-2: VistaLINK[®] Controlled Parameters**7.4. VISTALINK[®] TRAPS**

Trap	Description
Video Present Fault	Triggers when video is missing
AES 1 Present Fault	Triggers when AES 1 audio is missing
AES 2 Present Fault	Triggers when AES 2 audio is missing
AES 3 Present Fault	Triggers when AES 3 audio is missing
AES 4 Present Fault	Triggers when AES 4 audio is missing
Audio Embedder Fault	Triggers when there is a fault in the embedders

Table 7-3: VistaLINK[®] Traps

This page left intentionally blank