

---

---

## TABLE OF CONTENTS

1.	OVERVIEW.....	1
2.	INSTALLATION.....	3
3.	SPECIFICATIONS.....	5
3.1.	SERIAL VIDEO INPUT .....	5
3.2.	SERIAL VIDEO OUTPUTS WITH EMBEDDED AUDIO .....	5
3.3.	AES AUDIO INPUTS .....	5
3.4.	SYSTEM PERFORMANCE .....	5
3.5.	ELECTRICAL .....	5
3.6.	PHYSICAL.....	6
4.	STATUS LEADS.....	7
4.1.	MODULE STATUS LEADS .....	7
4.2.	AUDIO GROUP AND MODE STATUS LEADS.....	7
5.	CARD EDGE CONTROLS .....	9
5.1.	SELECTING THE AUDIO GROUPS THAT WILL BE EMBEDDED.....	9
5.2.	SELECTING THE AUDIO DELAY .....	11
5.3.	SELECTING HOW EXISTING EMBEDDED AUDIO WILL BE HANDLED AND WHERE THE EMBEDDED AUDIO WILL BE PLACED .....	11
5.4.	SELECTING AES LOCKED GROUP MODE.....	12
5.5.	SELECTING SAMPLE RATE CONVERSION FOR AES INPUTS.....	12
5.6.	SELECTING FUNCTION OF THE MODULE OK STATUS LED.....	13
5.7.	SELECTING OPERATION WHEN THERE IS NO VIDEO INPUT.....	13
6.	JUMPERS.....	14
6.1.	SELECTING WHETHER LOCAL FAULTS WILL BE MONITORED BY THE GLOBAL FRAME STATUS .....	14
6.2.	CONFIGURING THE MODULE FOR FIRMWARE UPGRADES .....	14
6.3.	RESETTING THE MODULE TO ITS FACTORY DEFAULT CONDITION .....	15

**Figures**

Figure 1-1: 7720AE4 Block Diagram..... 2  
Figure 2-1: 7720AE4 Rear Panels ..... 3  
Figure 6-1: Location of Jumpers ..... 14

**Tables**

Table 4-1: Audio Group and Mode Status LEDs..... 8  
Table 5-1: Toggle Switch Function Overview ..... 9  
Table 5-2: Embedder 1 Enable Switch Settings ..... 10  
Table 5-3: Embedder 1 Group Switch Settings..... 10  
Table 5-4: Embedder 2 Enable Switch Settings ..... 10  
Table 5-5: Embedder 2 Group Switch Settings..... 10  
Table 5-6: Audio Delay Switch Settings ..... 11  
Table 5-7: HANC Handling Mode Switch Settings..... 11  
Table 5-8: Lock Group Mode Switch Settings..... 12  
Table 5-9: Sample Rate Conversion Switch Settings ..... 12  
Table 5-10: Module OK Status LED Switch Settings ..... 13  
Table 5-11: Loss of Video Mode Switch Settings ..... 13

## REVISION HISTORY

<u>REVISION</u>	<u>DESCRIPTION</u>	<u>DATE</u>
1.0	First Release Version	Mar 03
1.1	Added section on resetting to factory defaults	Aug 03
1.2	Updated rear plate drawing. General format cleanup.	May 09

Information contained in this manual is believed to be accurate and reliable. However, Evertz assumes no responsibility for the use thereof nor for the rights of third parties, which may be affected in any way by the use thereof. Any representations in this document concerning performance of Evertz products are for informational use only and are not warranties of future performance, either expressed or implied. The only warranty offered by Evertz in relation to this product is the Evertz standard limited warranty, stated in the sales contract or order confirmation form.

Although every attempt has been made to accurately describe the features, installation and operation of this product in this manual, no warranty is granted nor liability assumed in relation to any errors or omissions unless specifically undertaken in the Evertz sales contract or order confirmation. Information contained in this manual is periodically updated and changes will be incorporated into subsequent editions. If you encounter an error, please notify Evertz Customer Service department. Evertz reserves the right, without notice or liability, to make changes in equipment design or specifications.

This page left intentionally blank

## 1. OVERVIEW

The 7720AE4 Audio Embedder inserts AES audio signals into a 270 Mb/s SDI video signal as specified in SMPTE 272M. The companion 7720AD4 Audio Deembedder facilitates audio demultiplexing at the destination.

SMPTE 272M allocates four groups of four audio channels that can be embedded into the SMPTE 259M bitstream. The 7720AE4 embeds up to 4 AES audio into two selectable groups on the SDI outputs for discrete 5.1 audio applications. The 7720AE4 is Dolby E™ compliant when the sample rate converters are turned off.

VistaLINK® enables control and configuration capabilities via Simple Network Management Protocol (SNMP). This offers the flexibility to manage the module status monitoring and configuration from SNMP enabled control systems such as Evertz VistaLINK® Pro locally or remotely.

### Features:

- Automatic detection of 525 line and 625 line input
- Bypass relay protection on one SDI output for power failures
- 20-bit AES input and audio embedding
- Individual audio group assignment for each group
- Group lock mode maintains phase relationship between the groups for 5.1 audio applications
- Sample rate conversion disabled on AES inputs to permit Dolby E™ embedding
- Programmable audio delays (up to 7 frames in ½ video field resolution) using DIP switches
- Ancillary packet cleaning mode removes all audio before embedding
- Ancillary packet reformatting mode left justifies and removes unused packets before embedding
- Embeds audio on internally generated black or blue video when there is no video input
- VistaLINK® control capabilities for module configuration. VistaLINK® capabilities are available when modules are used with the 3RU 7700FR-C frame and a 7700FC VistaLINK® Frame Controller module in slot 1 of the frame (feature not implemented at this time)
- Front panel LEDs indicate video and audio signal presence, and module fault

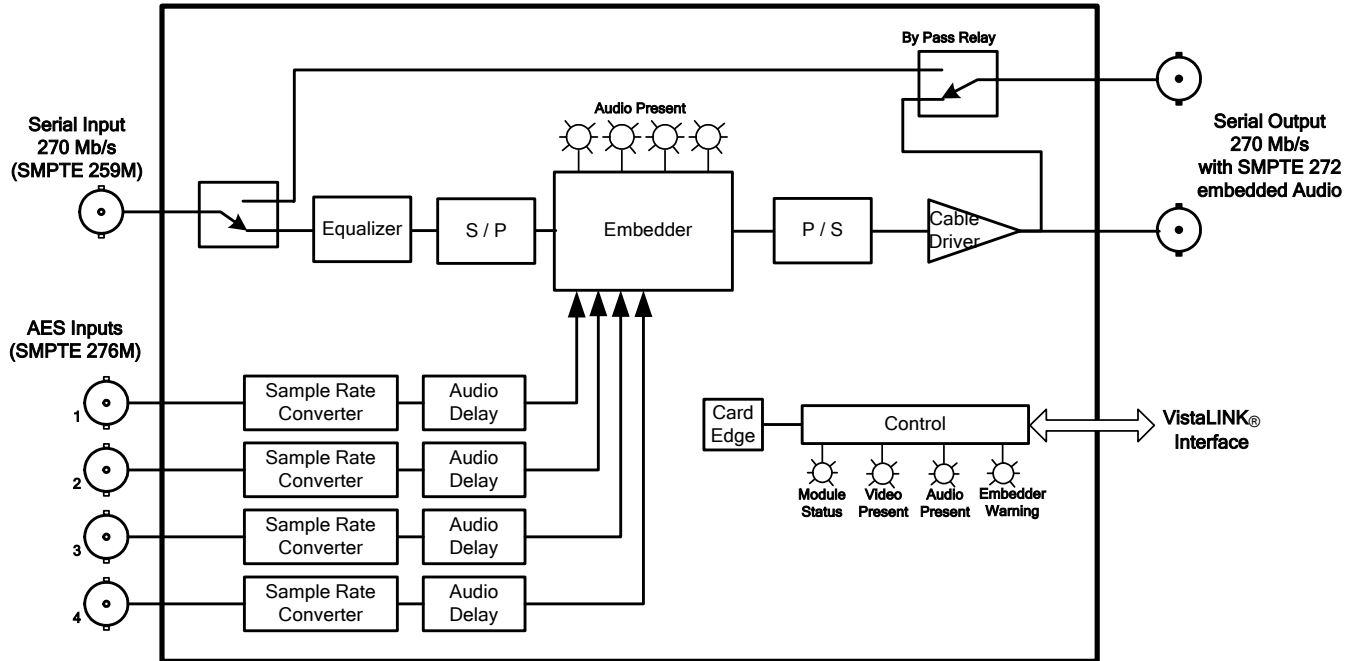
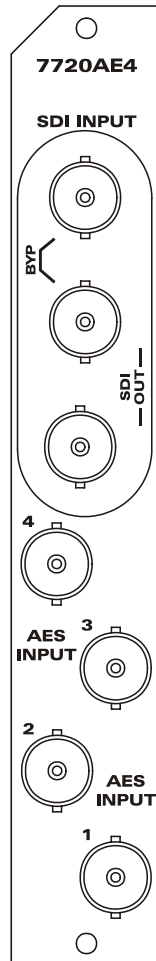

Figure 1-1: 7720AE4 Block Diagram

## 2. INSTALLATION

The 7720AE4 modules each come with a companion rear plate that has 7 BNC connectors. For information on mounting the rear plate and inserting the module into the frame see section 3 of the 7700FR chapter.



**Figure 2-1: 7720AE4 Rear Panels**

- SDI INPUT:** Input BNC connector for 10-bit serial digital video signals compatible with the SMPTE 259M standard.
- SDI OUTPUT:** There are two BNC connectors with reclocked serial component video outputs, compatible with the SMPTE 259M standard. These outputs contain the input video with the audio present at AES inputs 1 to 4 embedded in accordance with the SMPTE 272M standard. On the 7720AE4 the top SDI output is protected by a bypass relay, which will activate in the event of power loss to the module. The remaining output is not bypass protected.
- AES INPUT 1:** AES audio input for channel 1 and 2 of the audio group selected for embedding by embedder 1.

- 
- AES INPUT 2:** AES audio input for channel 3 and 4 of the audio group selected for embedding by embedder 1.
- AES INPUT 3:** AES audio input for channel 1 and 2 of the audio group selected for embedding by embedder 2.
- AES INPUT 4:** AES audio input for channel 3 and 4 of the audio group selected for embedding by embedder 2.



### 3. SPECIFICATIONS

#### 3.1. SERIAL VIDEO INPUT

**Standard:** SMPTE 259M C (270 Mb/s) 525 or 625 line component  
**Connector:** 1 BNC per IEC 61169-8 Annex A  
**Equalization:** Automatic 210m @ 270 Mb/s with Belden 8281 or equivalent cable  
**Return Loss:** > 15 dB up to 540 Mb/s

#### 3.2. SERIAL VIDEO OUTPUTS WITH EMBEDDED AUDIO

**Standard:** Same as input  
**Number of Outputs:** 2 (1 output bypass relay protected)  
**Embedded Audio:** SMPTE 272M – 20 bit 48 kHz synchronous  
**Connectors:** 1 BNC per IEC 61169-8 Annex A  
**Signal Level:** 800mV nominal  
**DC Offset:** 0V ±0.5V  
**Rise and Fall Time:** 900ps nominal  
**Overshoot:** <10% of amplitude  
**Return Loss:** > 15 dB up to 540 Mb/s  
**Wide Band Jitter:** < 0.2 UI

#### 3.3. AES AUDIO INPUTS

**Number of Inputs:** 4  
**Standard:** SMPTE 276M, single ended AES  
**Connector:** 1 BNC per IEC 61169-8 Annex A  
**Resolution:** 20 bits  
**Sampling Rate:** 32 to 96 kHz synchronous or asynchronous  
(48 kHz synchronous AES required when sample rate converter is disabled)  
**Impedance:** 75 Ohms unbalanced  
**Signal Level:** 1V p-p ±0.1V

#### 3.4. SYSTEM PERFORMANCE

**Embedding Latency:** 1.3 to 3.0 msec  
**Audio Delay:**  
**DIP Switch Control:** up to 7 frames, ½ frame increments (delay applied to all AES channels)  
**VistaLINK<sup>®</sup> or Serial Port Control:** up to 1.35 seconds in 1 sample increments (independent control of delay for each channel)

#### 3.5. ELECTRICAL

**Voltage:** + 12VDC  
**Power:** 9 Watts  
**EMI/RFI:** Complies with FCC Part 15, class A and EU EMC directive

### 3.6. PHYSICAL

<b>350FR:</b>	1
<b>7700FR-C:</b>	1
<b>7800FR:</b>	1

#### Stand Alone Enclosure:

**Dimensions:** 14 " L x 4.5 " W x 1.9 " H  
(355 mm L x 114 mm W x 48 mm H)

**Weight:** approx. 1.5 lbs. (0.7 Kg)

## 4. STATUS LEDS

The location of the status LEDs is shown in Figure 6-1.

### 4.1. MODULE STATUS LEDS

**MODULE OK:** This Green LED will be On when the module is operating properly. Depending on the Status LED mode chosen, the LED will be on solid when input video, or audio or both video and audio is present (see section 5.6)

**LOCAL FAULT:** This Red LED makes it easy to identify one module in a frame that is missing an essential input or has another fault.

The LED will blink on and off if the microprocessor is not running.

Depending on the Status LED mode chosen, the LED will be on solid when input video or audio is missing from all AES inputs, or both video and audio are missing. In addition this Led will be on when there is a fault in the module power supply.

**VIDEO PRESENT:** This Green LED will be On when there is a valid video signal present at the module input.

**AUDIO PRESENT:** This Green LED will be On solid when there is a valid AES audio signal present at any of the AES inputs. In *Locked Group* mode, the LED will be on when there is at least one input on the AES 1 or AES2 and AES 3 or AES 4 inputs.

**ERROR:** This Yellow LED will be On when there are errors in the embedding process (i.e. FIFO underflow)

### 4.2. AUDIO GROUP AND MODE STATUS LEDS

Four LEDs located on the lower end of the module (opposite the DIP switch) indicate the status of the audio groups when the DIP switches are all set to the OFF condition. LED 1 is located closest to the center of the module. When the DIP switches are set to other values, these LEDS are used to indicate various operational modes of the module. (See Table 4-1).

DIP Switch								Control Description	Value Description	LED			
1	2	3	4	5	6	7	8			1	2	3	4
Off	Off	Off	Off	Off	Off	Off	---	Audio Present	AES1 Present	On			
									AES2 Present		On		
									AES3 Present			On	
									AES4 Present				On
On	Off	Off	Off	Off	Off	Off	---	Audio Delay	Minimum	Off	Off	Off	Off
									½ frame	On	Off	Off	Off
									1 frame	Off	On	Off	Off
									1 ½ frames	On	On	Off	Off
									2 frames	Off	Off	On	Off
									2 ½ frames	On	Off	On	Off
									3 frames	Off	On	On	Off
									3 ½ frames	On	On	On	Off
									4 frames	Off	Off	Off	On
									4 ½ frames	On	Off	Off	On
									5 frame	Off	On	Off	On
									5 ½ frames	On	On	Off	On
									6 frames	Off	Off	On	On
									6 ½ frames	On	Off	On	On
								7 frames	Off	On	On	On	
								VistaLINK® / Remote control	On	On	On	On	
Off	On	Off	Off	Off	Off	Off	---	Embedder 1	Disable	Off	Off	Off	Off
									Enable	On	On	On	On
On	On	Off	Off	Off	Off	Off	---	Embedder 1 Group	Group 1	On	Off	Off	Off
									Group 2	Off	On	Off	Off
									Group 3	Off	Off	On	Off
									Group 4	Off	Off	Off	On
Off	Off	On	Off	Off	Off	Off	---	Embedder 2	Disable	Off	Off	Off	Off
									Enable	On	On	On	On
On	Off	On	Off	Off	Off	Off	---	Embedder 2 Group	Group 1	Off	Off	Off	Off
									Group 2	Off	On	Off	Off
									Group 3	Off	Off	On	Off
									Group 4	Off	Off	Off	On
Off	On	On	Off	Off	Off	Off	---	HANC Handling	Clean & embed	Off	Off	Off	Off
									Reformat and embed	On	On	On	On
On	On	On	Off	Off	Off	Off	---	Lock Groups	Independent Groups	Off	Off	Off	Off
									Locked Groups	On	On	On	On
Off	Off	Off	On	Off	Off	Off	---	Sample Rate Converter	Disable	Off	Off	Off	Off
									Enable	On	On	On	On
On	Off	Off	On	Off	Off	Off	---	Status LED Mode	Video Only	On	Off	Off	Off
									Audio Only	Off	On	Off	Off
									Video/ Audio	On	On	Off	Off
Off	On	Off	On	Off	Off	Off	---	Loss of Video Mode	Black	Off	Off	Off	Off
									Blue	On	On	On	On

Table 4-1: Audio Group and Mode Status LEDs

## 5. CARD EDGE CONTROLS

The 7720AE4 is equipped with an 8 position DIP switch to allow the user to select various functions. All positions are assigned sequentially such that the first position is located at the left side of the DIP switch (farthest from to the card ejector). When the switches are set to Off the LED status indicators near the DIP switch indicate the presence of the AES audio. When other DIP switch combinations are selected various operation modes of the module can be set using the toggle switch. The LED Mode indicators near the DIP switch indicate the settings of each of these modes as shown in Table 4-1. The On position is down, or closest to the printed circuit board. Sections 5.1 to 5.7 show the assigned DIP switch functions.

DIP Switch								Control Description
1	2	3	4	5	6	7	8	
Off	Off	Off	Off	Off	Off	Off	Off	Audio Present
On	Off	Off	Off	Off	Off	Off	Off	Audio Delay
Off	On	Off	Off	Off	Off	Off	Off	Embedder 1 Enable
On	On	Off	Off	Off	Off	Off	Off	Embedder 1 Group
Off	Off	On	Off	Off	Off	Off	Off	Embedder 2 Enable
On	Off	On	Off	Off	Off	Off	Off	Embedder 2 Group
Off	On	On	Off	Off	Off	Off	Off	HANC Handling Mode
On	On	On	Off	Off	Off	Off	Off	Lock Groups
Off	Off	Off	On	Off	Off	Off	Off	Sample Rate Converter Mode
On	Off	Off	On	Off	Off	Off	Off	Status LED Mode
Off	On	Off	On	Off	Off	Off	Off	Loss of Video Mode
---	---	---	---	---	---	---	On	VistaLINK <sup>®</sup> or Remote Control

**Table 5-1: Toggle Switch Function Overview**

### 5.1. SELECTING THE AUDIO GROUPS THAT WILL BE EMBEDDED

The SMPTE 272M standard permits up to 4 groups of 4 audio channels to be embedded into the 270 Mb/s video bitstream. Model 7720AE4 has two separate embedders that will embed up to four audio channels (two AES pairs) into one of the groups. The Embedders can be treated as two independent embedders for unrelated audio content or can be locked together where the audio in both groups is related and hence its phase must be maintained (i.e. 5.1 surround sound audio).



**Some legacy equipment may not be compatible with two embedded audio groups present in the video stream.**

The source for Embedder A is the audio coming in on the AES IN 1 and 2 connectors. The source for Embedder B is the audio coming in on the AES IN 3 and 4 connectors. There are separate DIP switch settings used to enable or disable each embedder and to set the audio groups where the embedders will put the audio on the SDI output.

When the DIP switches are as shown in Table 5-2, the toggle switch is used to enable or disable Embedder 1. Each time the toggle switch is pressed up or down the Embedder 1 Enable mode will change as indicated by the LEDs in Table 5-2.

When set to *Disable* embedder 1 will be disabled. When it is set to *Enable*, the embedder destination can be set when the DIP switches are set as shown in Table 5-3. Channels 1 and 2 from AES input 1 will be embedded into channels 1 and 2 of the selected group. Channels 1 and 2 from AES input 2 will be embedded into channels 3 and 4 of the selected group. If audio is not present on one or both of the AES inputs, the respective channels of the selected audio group will be mute.

DIP Switch								Control Description	Value Description	LED			
1	2	3	4	5	6	7	8			1	2	3	4
Off	On	Off	Off	Off	Off	Off	Off	Embedder 1	Disable	Off	Off	Off	Off
									Enable	On	On	On	On

**Table 5-2: Embedder 1 Enable Switch Settings**

DIP Switch								Control Description	Value Description	LED			
1	2	3	4	5	6	7	8			1	2	3	4
On	On	Off	Off	Off	Off	Off	Off	Embedder 1 Group	Group 1	On	Off	Off	Off
									Group 2	Off	On	Off	Off
									Group 3	Off	Off	On	Off
									Group 4	Off	Off	Off	On

**Table 5-3: Embedder 1 Group Switch Settings**

When the DIP switches are as shown in Table 5-4, the toggle switch is used to enable or disable Embedder 2. Each time the toggle switch is pressed up or down the Embedder 2 Enable mode will change as indicated by the LEDs in Table 5-4.

When set to *Disable* embedder 2 will be disabled. When it is set to *Enable* the embedder destination can be set when the DIP switches are configured as shown in Table 5-5. Channels 1 and 2 from AES input 3 will be embedded into channels 1 and 2 of the selected group. Channels 1 and 2 from AES input 4 will be embedded into channels 3 and 4 of the selected group. If audio is not present on one or both of the AES inputs, the respective channels of the selected audio group will be mute.

DIP Switch								Control Description	Value Description	LED			
1	2	3	4	5	6	7	8			1	2	3	4
Off	Off	On	Off	Off	Off	Off	Off	Embedder 2	Disable	Off	Off	Off	Off
									Enable	On	On	On	On

**Table 5-4: Embedder 2 Enable Switch Settings**

DIP Switch								Control Description	Value Description	LED			
1	2	3	4	5	6	7	8			1	2	3	4
On	Off	On	Off	Off	Off	Off	Off	Embedder 2 Group	Group 1	On	Off	Off	Off
									Group 2	Off	On	Off	Off
									Group 3	Off	Off	On	Off
									Group 4	Off	Off	Off	On

**Table 5-5: Embedder 2 Group Switch Settings**

## 5.2. SELECTING THE AUDIO DELAY

When the DIP switches are as shown in Table 5-6, the toggle switch is used to select one of fifteen delays which can be added to the audio before it is embedded. This delay allows the user to resynchronize the audio back to the video to accommodate video processing delays. The delay is applied to all AES channels prior to embedding.

DIP Switch								Control Description	Value Description	LED				
1	2	3	4	5	6	7	8			1	2	3	4	
On	Off	Off	Off	Off	Off	Off	Off	Audio Delay	Minimum	Off	Off	Off	Off	
									½ frame	On	Off	Off	Off	Off
									1 frame	Off	On	Off	Off	Off
									1 ½ frames	On	On	Off	Off	Off
									2 frames	Off	Off	On	Off	Off
									2 ½ frames	On	Off	On	Off	Off
									3 frames	Off	On	On	Off	Off
									3 ½ frames	On	On	On	Off	Off
									4 frames	Off	Off	Off	On	Off
									4 ½ frames	On	Off	Off	On	Off
									5 frame	Off	On	Off	On	Off
									5 ½ frames	On	On	Off	On	Off
									6 frames	Off	Off	On	On	Off
									6 ½ frames	On	Off	On	On	Off
									7 frames	Off	On	On	On	Off

Table 5-6: Audio Delay Switch Settings

## 5.3. SELECTING HOW EXISTING EMBEDDED AUDIO WILL BE HANDLED AND WHERE THE EMBEDDED AUDIO WILL BE PLACED

When the DIP switches are as shown in Table 5-7, the toggle switch is used to select how existing HANC packets will be handled by the embedder.

DIP Switch								Control Description	Value Description	LED			
1	2	3	4	5	6	7	8			1	2	3	4
Off	On	On	Off	Off	Off	Off	Off	HANC Handling	Clean & embed	Off	Off	Off	Off
									Reformat and embed	On	On	On	On

Table 5-7: HANC Handling Mode Switch Settings

When *Clean and embed* is selected, all incoming HANC packets and embedded audio data will be removed; and new audio data will be embedded after EAV. The remaining H blanking period is filled with default blanking value.

When *Reformat and embed* is selected, pre-existing embedded audio contents will be extracted. All packets with "Marked Packet for Deletion" or containing the same selected audio groups that are selected for embedding will be removed. The remaining packets are left justified and new audio will be embedded after these packets.

#### 5.4. SELECTING AES LOCKED GROUP MODE

For audio that is synchronous to video there is exactly 8008 audio samples (48kHz sampling rate) in 5 frames of NTSC, 525 line video. Most audio embedders will spread these samples as evenly as possible throughout the 5 frames of video. Because the 8008 samples do not divide evenly into 5 frames of video, there is a sequence that only repeats every 5 frames. In all video standards it is possible for the phase of the audio being embedded by two separate embedders to be out of phase with respect to each other. In order to transport 8 channels of audio (4 AES pairs) through an embedded link with exactly the same delay on each channel, both the embedder and the de-embedder must lock the FIFOs of both groups of audio together. Failing to do so will cause a phase difference between the audio from the two groups.

When the DIP switches are set as shown in Table 5-8, the toggle switch is used to select whether the embedders will be operated separately or locked together for embedding related audio (such as 5.1 surround sound).

DIP Switch								Control Description	Value Description	LED			
1	2	3	4	5	6	7	8			1	2	3	4
On	On	On	Off	Off	Off	Off	Off	Lock Groups	Independent Groups	Off	Off	Off	Off
									Locked Groups	On	On	On	On

**Table 5-8: Lock Group Mode Switch Settings**

When *Independent group* mode is selected, Embedder 1 and Embedder 2 are operated independently of each other as if two separate embedder devices were used. The FIFOs are not locked together and the output phases of the two groups of embedded audio do not have any specific relationship to each other.

When *Locked group* mode is selected, the Embedder FIFOs are locked together maintaining the phase relationship between all 4 AES channel pairs in the embedded audio.



**To maintain a guaranteed audio phase relationship through a complete SDI link, the audio de-embedder MUST also provide the same locked FIFO management functionality.**

#### 5.5. SELECTING SAMPLE RATE CONVERSION FOR AES INPUTS

When the DIP switches are set as shown in Table 5-9, the toggle switch is used to select whether the sample rate conversion for the AES inputs is enabled or not.

DIP Switch								Control Description	Value Description	LED			
1	2	3	4	5	6	7	8			1	2	3	4
Off	Off	Off	On	Off	Off	Off	Off	Sample Rate Converter	Disable	Off	Off	Off	Off
									Enable	On	On	On	On

**Table 5-9: Sample Rate Conversion Switch Settings**

When the Sample Rate converters are *Enabled* the AES inputs are sample rate converted at 48 kHz which is synchronous to the input video. AES inputs can be either synchronous or asynchronous to the video source.

When the Sample Rate converters are *Disabled* the content of AES inputs is preserved without any loss, and directly embedded into the input video. AES inputs must be synchronous to the video source. This setting is required when embedding Dolby E™.



### 5.6. SELECTING FUNCTION OF THE MODULE OK STATUS LED

When the DIP switches are set as shown in Table 5-10, the toggle switch is used to select the function of the Module OK LED status indicator. (See section 4.1)

DIP Switch								Control Description	Value Description	LED			
1	2	3	4	5	6	7	8			1	2	3	4
On	Off	Off	On	Off	Off	Off	Off	Status LED Mode	Video Only	On	Off	Off	Off
									Audio Only	Off	On	Off	Off
									Video/ Audio	On	On	Off	Off

**Table 5-10: Module OK Status LED Switch Settings**

In the *Video only* mode the Module OK status LED will be On when there is video present.

In the *Audio only* mode the Module OK status LED will be On when there is audio present on at least one of the AES inputs.

In the *Video and Audio* mode the Module OK status LED will be On when there is video present and there is audio present on at least one of the AES inputs.

### 5.7. SELECTING OPERATION WHEN THERE IS NO VIDEO INPUT

When there is no input video, the 7720AE4 will generate its own video and embed the audio onto it. When the DIP switches are as shown in Table 5-11, the toggle switch is used to select whether the module will generate black or blue video.

DIP Switch								Control Description	Value Description	LED			
1	2	3	4	5	6	7	8			1	2	3	4
Off	On	Off	On	Off	Off	Off	Off	Loss of Video Mode	Black	Off	Off	Off	Off
									Blue	On	On	On	On

**Table 5-11: Loss of Video Mode Switch Settings**

## 6. JUMPERS

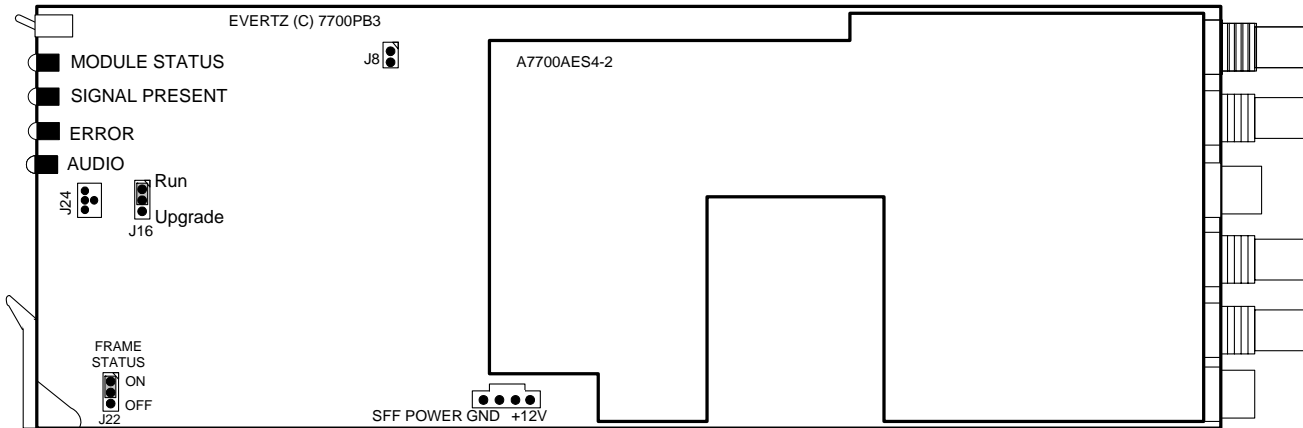

Figure 6-1: Location of Jumpers

### 6.1. SELECTING WHETHER LOCAL FAULTS WILL BE MONITORED BY THE GLOBAL FRAME STATUS

**FRAME STATUS:** The FRAME STATUS jumper located at the front of the module determines whether local faults (as shown by the Local Fault indicator) will be connected to the 7700FR frame's global status bus.

To monitor faults on this module with the frame status indicators (on the Power Supply FRAME STATUS LED's and on the Frame's Fault Tally output) install this jumper in the On position. (Default)

When this jumper is installed in the Off position, local faults on this module will not be monitored.

### 6.2. CONFIGURING THE MODULE FOR FIRMWARE UPGRADES

**UPGRADE:** The UPGRADE jumper J16 located at the front of the module is used when firmware upgrades are being done to the module. For normal operation it should be installed in the *RUN* position. See the *Upgrading Firmware* chapter in the front of the binder for more information.

To upgrade the firmware in the module unit pull it out of the frame. Move Jumper J16 into the *UPGRADE* position. Install the Upgrade cable provided (located in the vinyl pouch in the front of this manual) onto header J24 at the card edge. Re-install the module into the frame. Run the upgrade as described in the *Upgrading Firmware* chapter in the front of the binder. Once the upgrade is completed, remove the module from the frame, move J16 into the *RUN* position, remove the upgrade cable and re-install the module. The module is now ready for normal operation.

### 6.3. RESETTING THE MODULE TO ITS FACTORY DEFAULT CONDITION



**This operation will completely reset the module and all user settings will be erased. Make sure you want to reset the module before you proceed.**

Occasionally users want to reset the module to its factory default condition. The following procedure allows you to erase all user settings and restore the factory settings.

You will need the following equipment in order to reset the card to its factory defaults

- PC with available communications port.
- Terminal program that is capable of Xmodem file transfer protocol (such as HyperTerminal).
- Special Serial Upgrade cable supplied with the 7700FR-C frame. This cable is normally in the vinyl pouch at the front of this manual. (Evertz part #WA-76). A “Straight-thru” serial extension cable (DB9 female to DB9 male) may be required if you need to extend the length of the WA-S76 serial upgrade cable.

Reset Procedure:

1. Remove the module from the frame.
2. Move the UPGRADE jumper into the *UPGRADE* position.
3. Connect the 7700PB Serial Upgrade cable to the 2 row x 3 pin header labelled J24. Install the cable with the ribbon cable towards the front of the board.
4. Connect the 9 pin connector on the end of the Serial Update cable to the PCs’ RS-232 communications port.
5. Start the terminal program.
6. Configure the port settings of the terminal program as follows:

Baud	<b>57600</b>
Parity	<b>no</b>
Data bits	<b>8</b>
Stop bits	<b>2</b>
Flow Control	<b>None</b>

7. Install the module into the frame. After the module powers up, a banner with the boot code version information should appear in the terminal window.

**For example:**

```
EVERTZ MFC5407 MONITOR 2.1.3  
COPYRIGHT 1997, 1998, 1999, 2000, 2001, 2002 EVERTZ MICROSYSTEMS LTD.  
UPGRADE JUMPER INSTALLED  
  
UPLOAD FILE NOW, CONTROL-X TO CANCEL
```

8. The following is a list of possible reasons for failed communications:
  - Defective Evertz Serial Upgrade cable.
  - Wrong communications port selected in the terminal program.
  - Improper port settings in the terminal program. (Refer to step 5 for settings).
9. Press the <CTRL> and <X> keys. This will bring you to the boot prompt "7700 Boot>"
10. Type the word "reset", without quotes, and hit the <ENTER> key once. The boot code will ask `Are you sure?` Type "y", without quotes.
11. Wait one minute, power down the module. Remove the module from the frame and disconnect the Serial Upgrade cable from the module. Restore the UPGRADE jumper to the *RUN* position. Reinsert the module into the frame.
12. You can now close the terminal program and disconnect the RS-232 serial cable from the PC.
13. The module is now set to factory defaults.