

TABLE OF CONTENTS

1. OVERVIEW	1
2. INSTALLATION.....	2
3. SPECIFICATIONS.....	3
3.1. SERIAL VIDEO INPUT.....	3
3.2. SERIAL VIDEO OUTPUTS.....	3
3.3. ELECTRICAL	3
3.4. PHYSICAL	3
4. STATUS LEDS	4
5. JUMPERS AND USER ADJUSTMENTS.....	5
5.1. SELECTING WHETHER LOCAL FAULTS WILL BE MONITORED BY THE GLOBAL FRAME STATUS	5
5.2. SELECTING WHETHER MODULE WILL BE CONTROLLED FROM THE LOCAL CONTROLS OR THROUGH THE VISTALINK® INTERFACE	5
5.3. SELECTING THE RECLOCKING RATE.....	6
5.4. CONFIGURING THE MODULE FOR FIRMWARE UPGRADES	6
6. VISTALINK® REMOTE MONITORING/CONTROL.....	7
6.1. WHAT IS VISTALINK®?	7
6.2. VISTALINK® MONITORED PARAMETERS	7
6.3. VISTALINK® CONTROLLED PARAMETERS.....	8
6.4. VISTALINK® TRAPS.....	8

Figures

Figure 1-1: 7700DA7-HD Block Diagram	1
Figure 2-1: 7700DA7-HD Rear IO Module	2
Figure 5-1: LED and Jumper Locations.....	5

Tables

Table 6-1: VistaLINK® Monitored Parameters	7
Table 6-2: VistaLINK® Controlled Parameters.....	8
Table 6-3: VistaLINK® Traps	8

REVISION HISTORY

<u>REVISION</u>	<u>DESCRIPTION</u>	<u>DATE</u>
1.0	Original Version	Jun 05
1.1	Updated rear plate drawing. Updated VistaLINK section. General cleanup.	Feb 09
1.2	Minor update to section 3.1	Aug 14

Information contained in this manual is believed to be accurate and reliable. However, Evertz assumes no responsibility for the use thereof nor for the rights of third parties, which may be affected in any way by the use thereof. Any representations in this document concerning performance of Evertz products are for informational use only and are not warranties of future performance, either expressed or implied. The only warranty offered by Evertz in relation to this product is the Evertz standard limited warranty, stated in the sales contract or order confirmation form.

Although every attempt has been made to accurately describe the features, installation and operation of this product in this manual, no warranty is granted nor liability assumed in relation to any errors or omissions unless specifically undertaken in the Evertz sales contract or order confirmation. Information contained in this manual is periodically updated and changes will be incorporated into subsequent editions. If you encounter an error, please notify Evertz Customer Service department. Evertz reserves the right, without notice or liability, to make changes in equipment design or specifications.

This page left intentionally blank

1. OVERVIEW

The 7700DA7-HD Reclocking Distribution Amplifier provides reliable distribution of your 1.5 Gb/s HDTV and 143 Mb/s to 540 Mb/s standard definition serial digital video signals. The 7700DA7-HD features one auto-equalized input with seven reclocked outputs. The 7700DA7-HD has been designed to reclock at 1.5 Gb/s and 143 Mb/s to 540 Mb/s. In non-reclocking mode it can be used as a distribution product for SMPTE 310M (19.4 Mb/s) and all rates up to 1.5 Gb/s.

The 7700DA7-HD occupies one card slot in the 3 RU frame, which will hold up to 15 modules or the 1RU frame, which will hold up to three modules.

Features:

- Reclocking mode for SMPTE 292M (1.5 Gb/s), SMPTE 259M (143 to 360 Mb/s), SMPTE 344M (540 Mb/s) or DVB-ASI signals - auto detects correct bitrate
- Non-reclocking mode for signals from 19.4 Mb/s (SMPTE 310M) up to 1.5 Gb/s
- Fully hot-swappable from front of frame with no BNC disconnect required
- Independent isolated output drivers to ensure no cross channel loading effects (i.e. no need to terminate unused outputs)
- Outputs maintain polarity from input to output for DVB-ASI applications
- Tally output on Frame Status bus upon loss of input signal for quality monitoring
- VistaLINK[®] - enabled offering remote monitoring, control and configuration capabilities via SNMP. VistaLINK[®] is available when modules are used with the 3RU 7700FR-C frame and a 7700FC VistaLINK[®] Frame Controller module in slot 1 of the frame using the model 9000NCP Network Control Panel or Evertz VistaLINK[®] PRO or other third party SNMP manager software.

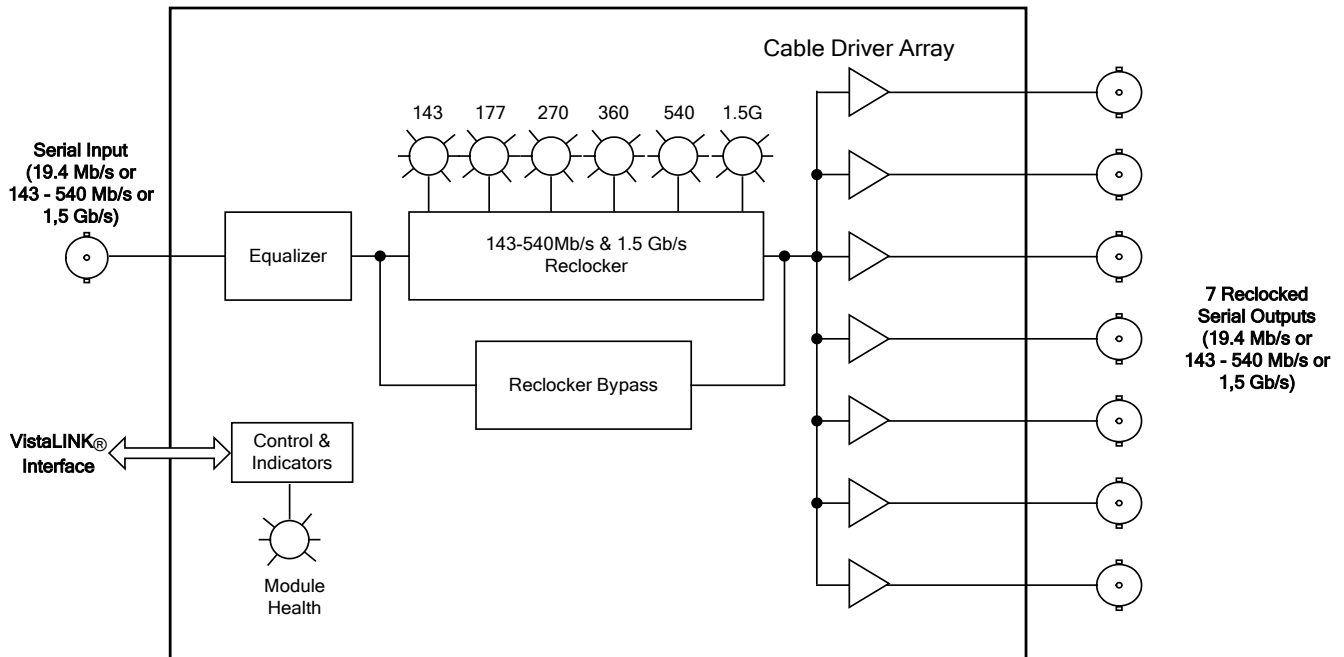

Figure 1-1: 7700DA7-HD Block Diagram

2. INSTALLATION

The 7700DA7-HD comes with a companion rear plate that occupies one slot in the frame. For information on inserting the module into the frame see the 7700FR chapter section 3.

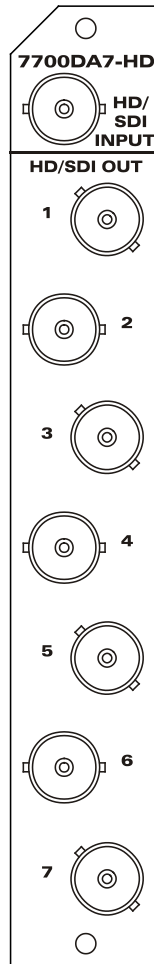

Figure 2-1: 7700DA7-HD Rear IO Module

SDI INPUT: Input BNC connector for 10-bit serial digital video signals compatible with the SMPTE 292M, SMPTE 259M, DVB-ASI or SMPTE 310M standard. See section 5.2 for information on choosing the correct video standard.

SDI OUTPUT: There are seven BNC connectors with reclocked serial component video outputs, compatible with the SMPTE 292M, SMPTE 259M / DVB-ASI, or SMPTE 310M standard.

3. SPECIFICATIONS

3.1. SERIAL VIDEO INPUT

Standards:

Reclocking Mode: SMPTE 292M SMPTE 259M A, B, C, D (143 to 360 Mb/s),
SMPTE 344M (540 Mb/s) DVB-ASI, or M2S

Non reclocking Mode: SMPTE 310M (19.4 Mb/s) to 1.5 Gb/s

Connector: 1 BNC per IEC 61169-8 Annex A

Equalization: Automatic to 100m @ 1.5 Gb/s with Belden 1694A or equivalent cable

Return Loss: > 15 dB up to 1.5 Gb/s

3.2. SERIAL VIDEO OUTPUTS

Number of Outputs: 7 Reclocked

Connector: BNC per IEC 61169-8 Annex A

Signal Level: 800mV nominal

DC Offset: 0V \pm 0.5V

Rise and Fall Time:

SD Video 740ps nominal

HD Video 200ps nominal

Overshoot: < 10% of amplitude

Return Loss: > 15 dB up to 1.5 Gb/s

Wide Band Jitter: < 0.2 UI

3.3. ELECTRICAL

Voltage: + 12VDC

Power: 5 Watts

Safety: CSA Listed to CSA C22.2 No. 60065-03, UL 60065-03
IEC 60065-(2001-12) 7th Edition

Complies with CE Low voltage Directive 93/68/EEC

EMI/RFI: Complies with FCC regulations for class A devices.

Complies with EU EMC directive 89/336/EEC

3.4. PHYSICAL

Number of slots: 1

4. STATUS LEDES

The 7700DA7-HD has eight LED Status indicators on the front card edge to show operational status of the card at a glance. Figure 5-1 shows the location of the LEDs.

Two large LEDs on the front of the board indicate the general health of the module.

LOCAL FAULT: This Red LED indicates poor module health and will be On during the absence of a valid input signal or if a local input power fault exists (i.e.: a blown fuse). The LOCAL FAULT indication can also be reported to the frame through the FRAME STATUS jumper.

MODULE OK: This Green LED indicates good module health. It will be On when a valid input signal is present, and board power is good.

There are six small LEDs that indicate the status of the equalizer and reclocker.

LOCK: This Green LED will be On when there is a valid signal present at the module input.

RECLOCKER RATE: There are 5 LEDs that indicate the rate (143, 177, 270, 360 or 540 Mb/s) that the reclocker is currently using when the Rate jumper is set to the 259M/344M position.

5. JUMPERS AND USER ADJUSTMENTS

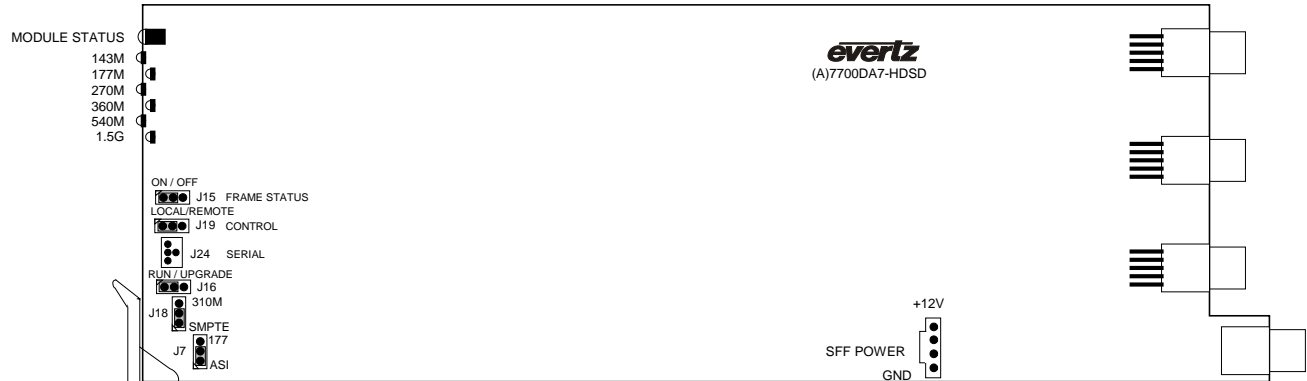

Figure 5-1: LED and Jumper Locations

5.1. SELECTING WHETHER LOCAL FAULTS WILL BE MONITORED BY THE GLOBAL FRAME STATUS

The FRAME STATUS jumper J15, located at the front of the module determines whether local faults (as shown by the Local Fault indicator) will be connected to the 7700FR frame's global status bus.

FRAME STATUS: To monitor faults on this module with the frame status indicators (on the power supply's FRAME STATUS LED's and on the Frame's Fault Tally output) install this jumper in the On position.

When this jumper is installed in the Off position local faults on this module will not be monitored.

5.2. SELECTING WHETHER MODULE WILL BE CONTROLLED FROM THE LOCAL CONTROLS OR THROUGH THE VISTALINK® INTERFACE

The CONTROL jumper J19 selects whether the module will be controlled from the local jumpers or through the VistaLINK® interface.

CONTROL: When this jumper is installed in the LOCAL position, the card functions are controlled through the local jumpers.

When this jumper is installed in the REMOTE position, the card functions are controlled through the VistaLINK® interface.

5.3. SELECTING THE RECLOCKING RATE

The RATE jumper J18, located at the front of the module near the card ejector, determines whether the module will operate as a reclocking distribution amplifier with SMPTE 292M, SMPTE 259M or 344M (143 to 540 Mb/s) or DVB-ASI video signals or with SMPTE 310M (19.4 Mb/s) signals.

RATE SELECT: To set the module to operate with SMPTE 292M, SMPTE 259M, SMPTE 344M or DVB-ASI signals install the jumper in the SMPTE position.

To set module to operate with SMPTE 310M signals install the jumper in the 310M position.

The SUPPORT jumper J7, located at the front of the module near the card ejector, determines whether the module will operate as a reclocking distribution amplifier with SMPTE 292M or SMPTE 259M or 344M (143 to 540 Mb/s) or DVB-ASI video signals.

SUPPORT: To set the module to operate with SMPTE 292M, SMPTE 259M or SMPTE 344M signals install the jumper in the 177 position.

To set module to operate with DVB-ASI signals install the jumper in the DVB position.

5.4. CONFIGURING THE MODULE FOR FIRMWARE UPGRADES

UPGRADE: The UPGRADE jumper J16, located at the front of the module near the card ejector, is used when firmware upgrades are being done to the module. For normal operation it should be installed in the *RUN* position. See the *Upgrading Firmware* section in the front of the binder for more information.

To upgrade the firmware in the module unit pull it out of the frame. Move Jumper J16 into the *UPGRADE* position. Install the Upgrade cable provided (located in the vinyl pouch in the front of this manual) onto header J24. Re-install the module into the frame. Run the upgrade as described in the *Upgrading Firmware* section in the front of the binder. Once the upgrade is completed, remove the module from the frame, move J16 to the *RUN* position, remove the upgrade cable and re-install the module. The module is now ready for normal operation.

6. VISTALINK[®] REMOTE MONITORING/CONTROL

6.1. WHAT IS VISTALINK[®]?

VistaLINK[®] is Evertz's remote monitoring and configuration platform which operates over an Ethernet network using Simple Network Management Protocol (SNMP). SNMP is a standard computer network protocol that enables different devices sharing the same network to communicate with each other. VistaLINK[®] provides centralized alarm management, which monitors, reports, and logs all incoming alarm events and dispatches alerts to all the VLPro Clients connected to the server. Card configuration through VistaLINK[®] PRO can be performed on an individual or multi-card basis using simple copy and paste routines, which reduces the time to configure each module separately. Finally, VistaLINK[®] enables the user to configure devices in the network from a central station and receive feedback that the configuration has been carried out.

There are 3 components of SNMP:

1. An SNMP manager, also known as a Network Management System (NMS), is a computer running special software that communicates with the devices in the network. Evertz VL-Fiber demo Manager graphical user interface (GUI), third party or custom manager software may be used to monitor and control Evertz VistaLINK[®] enabled fiber optic products.
2. Managed devices (such as 7700DA7-HD), each with a unique address (OID), communicate with the NMS through an SNMP Agent. Evertz VistaLINK[®] enabled 7700 series modules reside in the 3RU 7700FR-C MultiFrame and communicate with the manager via the 7700FC VistaLINK[®] frame controller module, which serves as the Agent.
3. A virtual database, known as the Management Information Base (MIB), lists all the variables being monitored, which both the Manager and Agent understand. Please contact Evertz for further information about obtaining a copy of the MIB for interfacing to a third party Manager/NMS.

For more information on connecting and configuring the VistaLINK[®] network, see the 7700FC Frame Controller chapter.

6.2. VISTALINK[®] MONITORED PARAMETERS

The following parameters can be remotely monitored through the VistaLINK[®] interface.

Parameter	Description
Detected Video Standard	Indicates the detected video standard.
Video Locked	Indicates whether or not there is a video lock.
Card Type	Indicates version of the module (7700DA7 / 7700DA7-HD).
Master Jumper	Indicates whether the card is in Remote or Local Mode (position of the CONTROL jumper).

Table 6-1: VistaLINK[®] Monitored Parameters

6.3. VISTALINK® CONTROLLED PARAMETERS

Parameter	Description
Video Standard	Sets the current video standard you wish to lock to.
Bypass Mode	Sets the reclocker mode. If 'none', the reclocker is never bypassed. If 'auto', the reclocker is auto-bypassed when the PLL is not locked. If 'force', the reclocker is always bypassed.
Autolocking Mode	Sets the auto locking to DVB/ASI or 177Mb/s mode.

Table 6-2: VistaLINK® Controlled Parameters

6.4. VISTALINK® TRAPS

Trap	Description
Video Lock	Triggers when there is no video lock.

Table 6-3: VistaLINK® Traps