

TABLE OF CONTENTS

1. OVERVIEW	1
2. INSTALLATION.....	3
3. SPECIFICATIONS.....	4
3.1. SERIAL VIDEO INPUT	4
3.2. SERIAL VIDEO OUTPUTS.....	4
3.3. ELECTRICAL.....	4
3.4. PHYSICAL	4
4. STATUS LEADS	5
5. JUMPERS AND USER ADJUSTMENTS.....	6
5.1. SELECTING WHETHER LOCAL FAULTS WILL BE MONITORED BY THE GLOBAL FRAME STATUS.....	6
5.2. SELECTING WHETHER MODULE WILL BE CONTROLLED FROM THE LOCAL CONTROLS OR THROUGH THE VISTALINK[®] INTERFACE.....	6
5.3. SELECTING THE RECLOCKING RATE	7
5.4. CONFIGURING THE MODULE FOR FIRMWARE UPGRADES.....	7
 Figures	
Figure 1-1: 7700DA7-3G Block Diagram.....	2
Figure 2-1: 7700DA7-3G Rear IO Module.....	3
Figure 5-1: LED and Jumper Locations.....	6

REVISION HISTORY

<u>REVISION</u>	<u>DESCRIPTION</u>	<u>DATE</u>
0.1	Preliminary Version	Jun 2008
0.2	Modified Card drawing and controls	Jul 2008
0.3	Updated rear plate drawing	Feb 2009
1.0	First release	Jul 2013
1.1	Minor update to section 1 and 3.1	Aug 2014

Information contained in this manual is believed to be accurate and reliable. However, Evertz assumes no responsibility for the use thereof nor for the rights of third parties, which may be affected in any way by the use thereof. Any representations in this document concerning performance of Evertz products are for informational use only and are not warranties of future performance, either expressed or implied. The only warranty offered by Evertz in relation to this product is the Evertz standard limited warranty, stated in the sales contract or order confirmation form.

Although every attempt has been made to accurately describe the features, installation and operation of this product in this manual, no warranty is granted nor liability assumed in relation to any errors or omissions unless specifically undertaken in the Evertz sales contract or order confirmation. Information contained in this manual is periodically updated and changes will be incorporated into subsequent editions. If you encounter an error, please notify Evertz Customer Service department. Evertz reserves the right, without notice or liability, to make changes in equipment design or specifications.

1. OVERVIEW

The 7700DA7-3G reclocking distribution amplifier provides cost-efficient distribution of the SMPTE 424M, SMPTE 292M and SMPTE 259M serial digital video signals at rates of 3Gb/s, 1.5Gb/s and 270Mb/s. The DA supports all other SMPTE 344M, SMPTE 259M, SMPTE 310M and DVB-ASI data rates in a non-reclocked mode (540Mb/s, 360Mb/s, 143Mb/s, 19.4Mb/s). Ideal in applications where a large quantity of outputs is required, the DA features an auto-equalized input with seven isolated reclocked outputs.

The 7700DA7-3G occupies one card slot in the 3RU frame, which will hold up to 15 modules or the 1RU frame, which will hold up to three modules.

Features:

- Normal reclocked mode for SMPTE 424M (3Gb/s), SMPTE 292M (1.5Gb/s) and SMPTE 259M (270Mb/s)
- Remote selectable non-reclocked mode for all other SMPTE344M, SMPTE 259M, SMPTE 310M and DVB-ASI data rates
- Fully hot-swappable from front of frame with no BNC disconnect required
- Tally output on the Frame Status bus upon loss of input signal for quality monitoring
- VistaLINK[®] capable for remote monitoring via SNMP (using VistaLINK[®] PRO) when installed in the 7700FR frame with 7700FC VistaLINK[®] Frame Controller

Status LEDs:

- Detected Signal Rate LED's
- Control Mode LED
- Module Health Status

Input:

- SMPTE 424M (3Gb/s), SMPTE 292M (1.5Gb/s), SMPTE 259M (270Mb/s) when reclocking
- SMPTE 344M (540Mb/s), SMPTE 259 (360Mb/s, 143Mb/s), SMPTE 310M when not reclocking
- Return Loss > 15dB to 1.5Gb/s and > 10dB up to 3Gb/s
- Auto equalization to 80m at 3Gb/s, 150m @ 1.5Gb/s and 350m @ 270Mb/s

Output:

- 7 reclocked outputs
- Wideband jitter < 0.2 UI

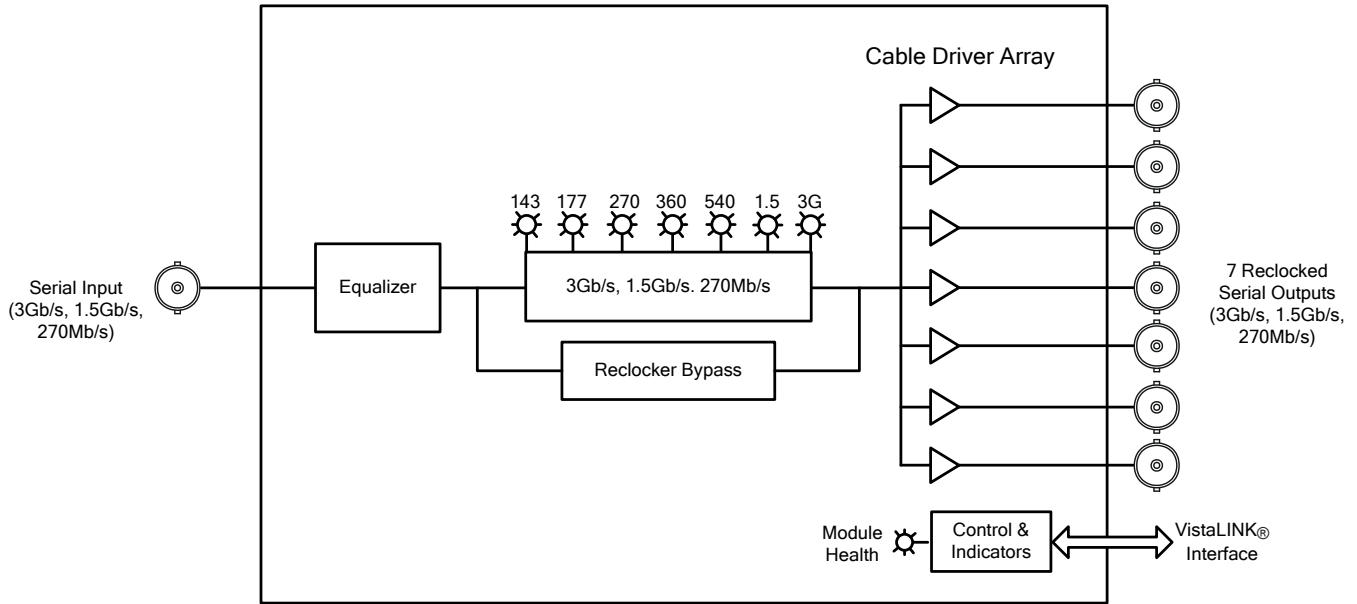

Figure 1-1: 7700DA7-3G Block Diagram

2. INSTALLATION

The 7700DA7-3G comes with a companion rear plate that occupies one slot in the frame. For information on inserting the module into the frame see section 3 of the 7700FR chapter.

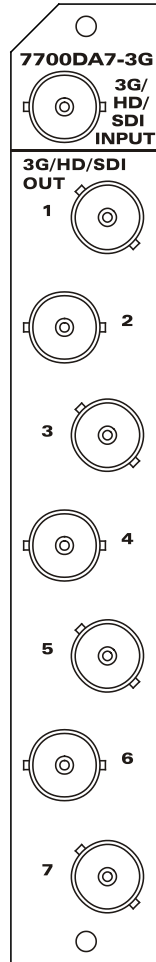

Figure 2-1: 7700DA7-3G Rear IO Module

3G/HD/SDI INPUT: Input BNC connector for 10-bit serial digital video signals compatible with the SMPTE 424M, SMPTE 292M, SMPTE 259M, DVB-ASI or SMPTE 310M standard. See section 5.2 for information on selecting the correct video standard.

3G/HD/SDI OUTPUT: There are seven BNC connectors with reclocked serial component video outputs, compatible with the SMPTE 424M, SMPTE 292M, and SMPTE 259M and non reclocked SMPTE 344M (540Mb/s), SMPTE 259 (360Mb/s, 143Mb/s) and SMPTE 310M.

3. SPECIFICATIONS

3.1. SERIAL VIDEO INPUT

Standards:

Reclocked Mode: SMPTE 424M (3Gb/s)
SMPTE 292M (1.5Gbs)
SMPTE 259M (270Mb/s)

Non reclocked Mode: SMPTE 344M (540Mb/s)
SMPTE 259M (360Mb/s, 143 Mb/s)
SMPTE 310M (19.4Mb/s, DVB-ASI)

Connector: BNC per IEC 61169-8 Annex A

Equalization: Automatic to 80m @ 3Gb/s, 150m @ 1.5Gb/s & 350m @ 270 Mb/s

Return Loss: > 15dB up to 1.5Gb/s
> 10dB up to 3Gb/s

3.2. SERIAL VIDEO OUTPUTS

Number of Outputs: 7 Reclocked
Connector: BNC per IEC 61169-8 Annex A
Signal Level: 800mV nominal
DC Offset: 0V \pm 0.5V
Rise and Fall Time: 150ps @ 3g/HD, 470ps SD nominal
Wide Band Jitter: < 0.2 UI

3.3. ELECTRICAL

Voltage: +12V DC
Power: 5 W
EMI/RFI: Complies with FCC Part 15, Class A
EU EMC Directive

3.4. PHYSICAL

Number of slots: 1

4. STATUS LEDS

The 7700DA7-3G has six LED Status indicators on the front card edge to show operational status of the card at a glance. Figure 5-1 shows the location of the LEDs.

Two large LEDs on the front of the board indicate the general health of the module

LOCAL FAULT: This Red LED indicates poor module health and will be On during the absence of a valid input signal or if a local input power fault exists (i.e. a blown fuse). The LOCAL FAULT indication can also be reported to the frame through the FRAME STATUS jumper.

REMOTE: This LED will come On when the Control jumper J19 is installed in ther Remote position.

MODULE OK: This Green LED indicates good module health. It will be On when a valid input signal is present, and board power is good.

RECLOCKER RATE: There are 3 LEDs that indicate the rate (143, 270Mb/s, and 1.5Gb/s) that the reclocker is currently using when the Rate jumper is set to the 259M/344M position.

5. JUMPERS AND USER ADJUSTMENTS

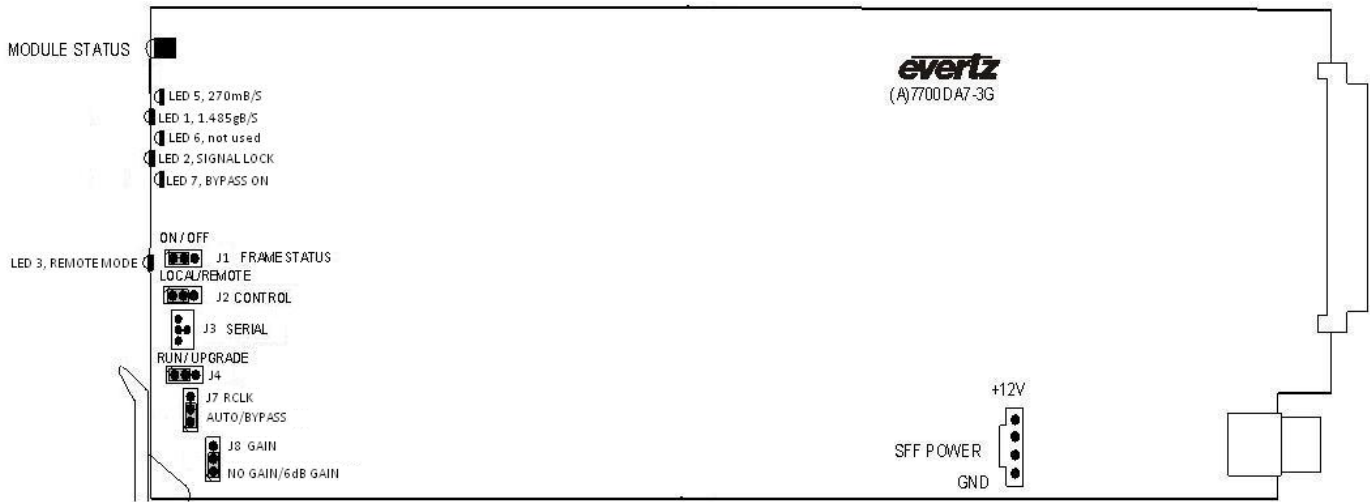

Figure 5-1: LED and Jumper Locations

5.1. SELECTING WHETHER LOCAL FAULTS WILL BE MONITORED BY THE GLOBAL FRAME STATUS

The FRAME STATUS jumper J1, located at the front of the module, determines whether local faults (as shown by the Local Fault indicator) will be connected to the 7700FR frame's global status bus.

FRAME STATUS: To monitor faults on this module with the frame status indicators (on the power supply's FRAME STATUS LED's and on the Frame's Fault Tally output) install this jumper in the On position.

When this jumper is installed in the Off position local faults on this module will not be monitored.

5.2. SELECTING WHETHER MODULE WILL BE CONTROLLED FROM THE LOCAL CONTROLS OR THROUGH THE VISTALINK® INTERFACE

The CONTROL jumper J2 selects whether the module will be controlled from the local jumpers or through the VistaLINK® interface.

CONTROL: When this jumper is installed in the LOCAL position, the card functions are controlled through the local jumpers.

When this jumper is installed in the REMOTE position, the card functions are controlled through the VistaLINK® interface.

5.3. SELECTING THE RECLOCKING RATE

The RCLK jumper J7, located at the front of the module near the card ejector, determines whether the module will operate as a re-clocking distribution amplifier with SMPTE 292M, SMPTE 259M or 344M (143 to 540 Mb/s) or DVB-ASI video signals or with SMPTE 310M (19.4 Mb/s) signals.

RATE SELECT: **Auto:** Re-clocking mode is set to auto based on sensed input signal.
 Bypass: Re-clocking mode is bypassed.

5.4. CONFIGURING THE MODULE FOR FIRMWARE UPGRADES

UPGRADE: The UPGRADE jumper J4 located at the front of the module near the card ejector, is used when firmware upgrades are being done to the module. For normal operation it should be installed in the *RUN* position. See the *Upgrading Firmware* section in the front of the binder for more information.

To upgrade the firmware in the module unit pull it out of the frame. Move Jumper J4 into the *UPGRADE* position. Install the Upgrade cable provided (located in the vinyl pouch in the front of this manual) onto header J3. Re-install the module into the frame. Run the upgrade as described in the *Upgrading Firmware* section in the front of the binder. Once the upgrade is complete, remove the module from the frame, move J4 to the *RUN* position, remove the upgrade cable and re-install the module. The module is now ready for normal operation.

This page left intentionally blank