

TABLE OF CONTENTS

1.	OVERVIEW	1
2.	INSTALLATION	4
3.	SPECIFICATIONS	6
3.1.	ANALOG AUDIO INPUT	6
3.2.	ANALOG AUDIO OUTPUTS	6
3.3.	ELECTRICAL	7
3.4.	PHYSICAL.....	7
4.	STATUS INDICATOR LEDES.....	8
5.	CARD EDGE CONTROLS	9
6.	JUMPERS.....	10
6.1.	SELECTING WHETHER LOCAL FAULTS WILL BE MONITORED BY THE GLOBAL FRAME STATUS.....	11
6.2.	SETTING THE AMPLIFIER CONFIGURATION	11
6.3.	SETTING THE AMPLIFIER GAIN	13
6.3.1.	Setting the Input Gain Level	14
6.3.2.	Setting the Output Gain Level.....	15
6.3.3.	Fine-Tuning the Gain Level	15

Figures

Figure 1-1: 7700ADA-AUD Block Diagram Rev 2	1
Figure 1-2: 7700ADA-AUD Block Diagram Rev A	2
Figure 1-3: 7700ADA-AUD Block Diagram Rev B	3
Figure 2-1: 7700ADA-AUD Rear Panel	4
Figure 4-1: LED Status Indicators	8
Figure 5-1: Card Edge Controls	9
Figure 6-1: Location of Jumpers – PCB Rev 2	10
Figure 6-2: Location of Jumpers – PCB Rev A	10
Figure 6-3: Location of Jumpers – PCB Rev B	11
Figure 6-4: Setting the Amplifier Output Configuration – Rev 2	12
Figure 6-5: Setting the Amplifier Output Configuration – Rev A	12
Figure 6-6: Setting the Amplifier Output Configuration – Rev B	13
Figure 6-7: Setting the Input Gain Level on PCB Rev 2	14
Figure 6-8: Setting the Input Gain Level on PCB Rev B and PCB Rev. A	14
Figure 6-9: Setting the Output Gain Level	15

Tables

Table 6-1: Amplifier Gain Levels on PCB Rev 2	13
Table 6-2: Amplifier Gain Levels on PCB Rev B and PCB Rev A	14

REVISION HISTORY

<u>REVISION</u>	<u>DESCRIPTION</u>	<u>DATE</u>
1.0	Preliminary Version	Apr 2002
1.1	Specifications and jumper setting info updated	May 2002
1.2	Updated Jumper location drawings for Rev A boards	Aug 2003
1.3	Updated User Manual for PCB Rev B boards	Nov 2006
1.4	Updated all drawings Added Block Diagram Rev. A Updated Amplifier Gain Levels	Jan 2007
1.5	General format clean up	Sept 2009
1.6	Updated diagram in Installation section	Dec 2012

Information contained in this manual is believed to be accurate and reliable. However, Evertz assumes no responsibility for the use thereof nor for the rights of third parties, which may be affected in any way by the use thereof. Any representations in this document concerning performance of Evertz products are for informational use only and are not warranties of future performance, either expressed or implied. The only warranty offered by Evertz in relation to this product is the Evertz standard limited warranty, stated in the sales contract or order confirmation form.

Although every attempt has been made to accurately describe the features, installation and operation of this product in this manual, no warranty is granted nor liability assumed in relation to any errors or omissions unless specifically undertaken in the Evertz sales contract or order confirmation. Information contained in this manual is periodically updated and changes will be incorporated into subsequent editions. If you encounter an error, please notify Evertz Customer Service department. Evertz reserves the right, without notice or liability, to make changes in equipment design or specifications.

This page left intentionally blank

1. OVERVIEW

The 7700ADA-AUD Dual Analog Audio distribution amplifier is a general purpose amplifier for distributing analog audio signals. It can be operated as two independent 4 output amplifiers for stereo signals or as a single amplifier with 8 outputs where higher fanout is required.

The 7700ADA-AUD can be operated with either differential or single ended inputs and offers a wide range of gain adjustment to handle a wide variety of input signals.

The 7700ADA-AUD occupies one card slot and can be housed in either a 1RU frame, which will hold up to three modules, or a 3 RU frame, which will hold up to 15 modules.

Features:

- Differential and single ended input (automatic single ended to differential conversion)
- Configurable for stereo (2-1x4), or mono (1x8)
- High impedance inputs
- Low impedance outputs
- Wide gain adjustment range
- High common mode range and common mode rejection ratio
- Very high SNR
- Very low THD+N
- Fully balanced signal path from input to output

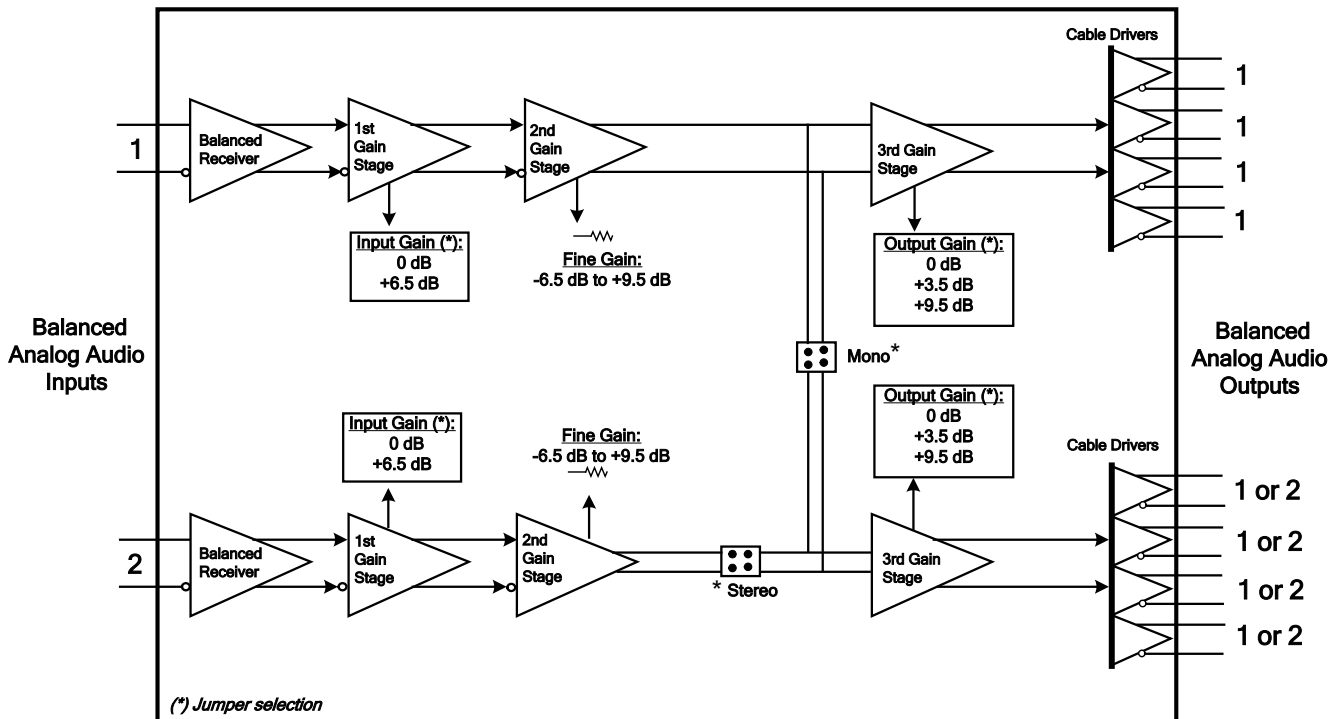

Figure 1-1: 7700ADA-AUD Block Diagram Rev 2

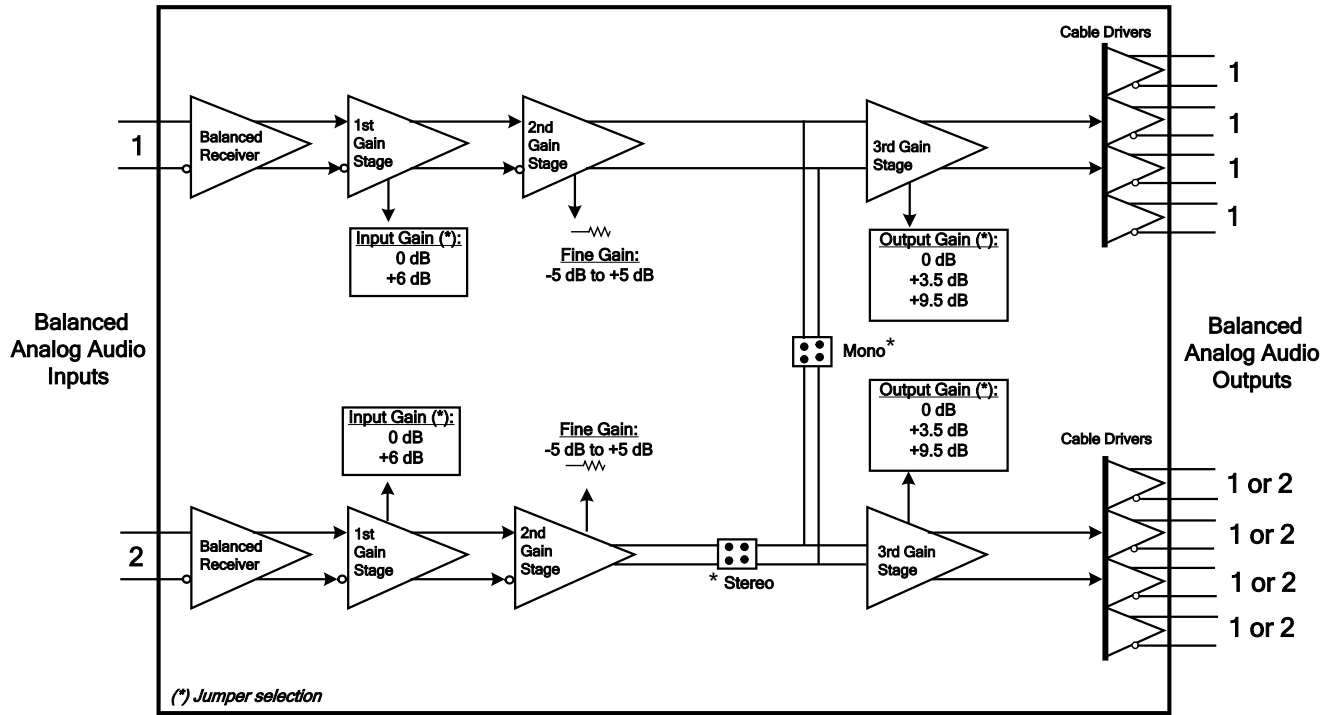

Figure 1-2: 7700ADA-AUD Block Diagram Rev A



The input gain on Rev. A modules older than November 2002 will be +6dB and the fine gain adjustment range will be - 6.5dB to + 9.5dB.

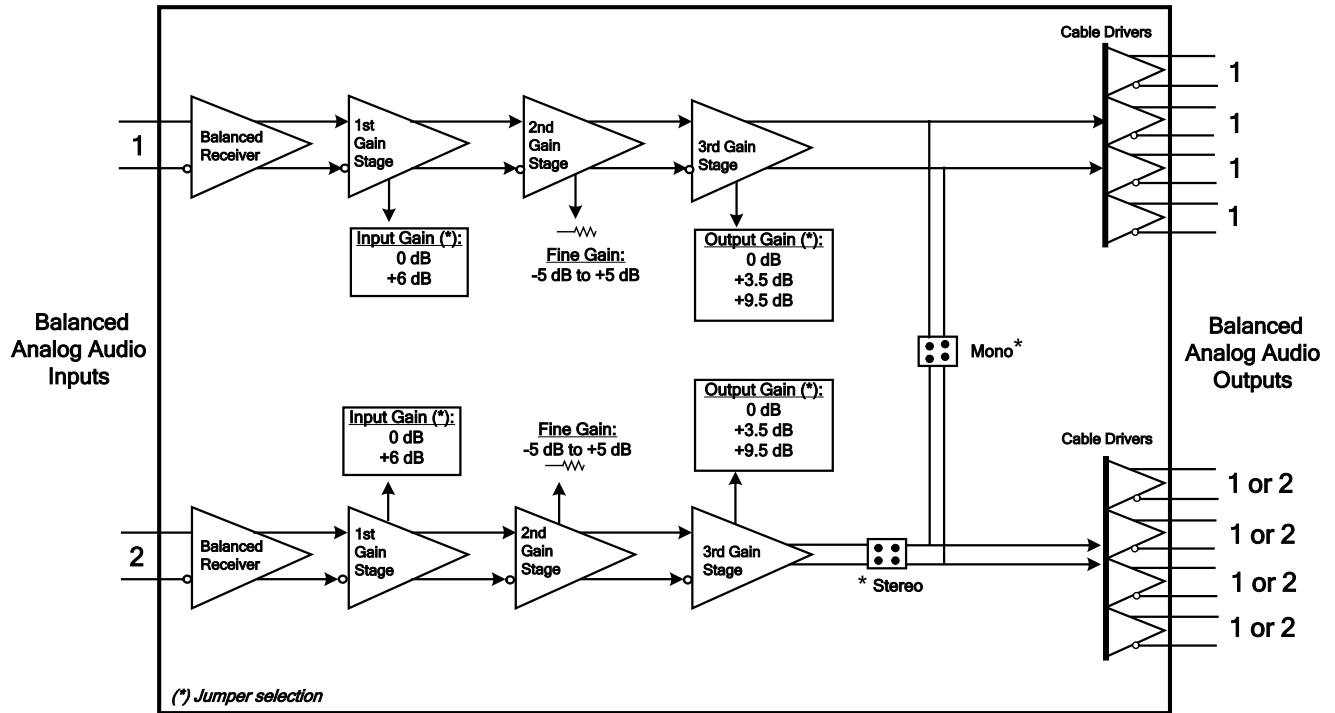

Figure 1-3: 7700ADA-AUD Block Diagram Rev B



When using the 7700ADA-AUD module for a mono 1x8 configuration, the 3rd Gain Stage for channel 2 on PCB Revisions 2 and A is configured separately for the lower four outputs. On PCB Rev B, the 3rd Gain Stage for channel 1 will adjust the gain for all 8 outputs.

2. INSTALLATION

The 7700ADA-AUD comes with a companion rear plate that has ten 3 pin removable terminal strips. For information on mounting the rear plate and inserting the module into the frame see section 3 of the 7700FR manual.

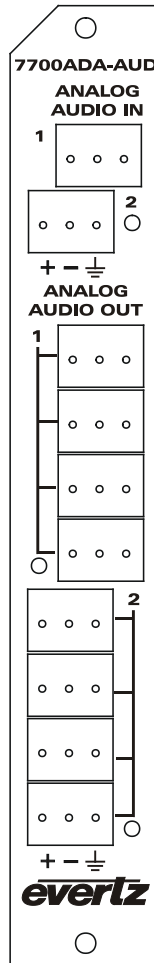

Figure 2-1: 7700ADA-AUD Rear Panel

The balanced audio cables can be secured into the removable portion of the terminal strips using a small screwdriver. The removable part of the terminal strip is then inserted into the terminal strips on the rear panel.

ANALOG AUDIO IN: Balanced analog audio inputs for 2 channels. Each input (+, -, GND) is on a 3 pin removable terminal strip connector.



For unbalanced audio connections, the signal wire should be connected to the positive (+) input and the shield (GND) should be connected to the negative (-) input.

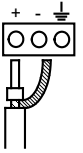

ANALOG AUDIO OUT: There are four balanced analog audio outputs for each of the 2 input channels. Each output (+, -, GND) is on a 3 pin removable terminal strip connector.



To connect an unbalanced cable to one of the balanced outputs of this card, the positive output (+) should connect to the signal wire, and the shield of the cable should connect to the ground terminal. The negative output (-) should be left unconnected.

This method has some drawbacks, such as half the amplitude (6dB less) than a balanced connection and may pick up common-mode noise with long cable lengths.

3. SPECIFICATIONS

3.1. ANALOG AUDIO INPUT

Standards:	Any analog audio signal
Number of Inputs:	2 (Balanced or Single ended)
Connectors:	3 pin removable terminal strips
Input Step Gain:	0 dB or +6.5 dB (configurable with jumpers) on PCB Rev 2 0 dB to 6 dB (configurable with jumpers) on PCB Rev A and PCB Rev B
Fine Gain Control:	-6.5 dB to +9.5 dB (card edge pot adjustable) on PCB Rev 2 -5 dB to +5 dB (card edge pot adjustable) on PCB Rev A and PCB Rev B
Maximum Input Level:	
0 dB Input Gain	+34 dBu
+6 dB Input Gain	+28 dBu
Noise Floor:	-87 dBu (0 dB input gain), -91 dBu (+6 dB input gain jumper setup)
Common Mode Rejection:	> 100 dB @ 70 Hz, 65 dB @ 20 kHz (tested with +24 dBu CM input)
Common Mode Range:	
0 dB Input Gain	> ± 22 V
+6 dB Input Gain	> ± 7 V
Input Impedance:	
0 dB Input Gain	33 k Ω
+6 dB Input Gain	15 k Ω

3.2. ANALOG AUDIO OUTPUTS

Number of Outputs:	
Stereo Mode:	4 Outputs each on left and right channels
Mono Mode:	8 Outputs
Connectors:	3 pin removable terminal strips
Output Step Gain:	0, 3.5 or 9.5 dB (configurable with jumpers)
Maximum Output Level:	+24 dBu across hi-impedance load +20 dBm into 600 ohm load
Output Impedance:	66 Ω
Frequency Response:	+/-0.03 dB 20 Hz to 20 kHz
Stereo Phase Mismatch:	< 1° @ 20 kHz
SNR:	115 dB
THD+ Noise:	0.001% 20 Hz to 20 kHz @ 28 dBu, unweighted RMS, hi-Z loads
Intermodulation Distortion:	0.001% - SMPTE @ 18 dBu
Stereo Crosstalk:	>115 dB @ 1 kHz, >100 dB @ 20 kHz
Output Isolation:	all outputs have independent drivers

3.3. ELECTRICAL

Voltage: +12VDC
Power: 12 Watts
EMI/RFI: Complies with FCC Part 15 Class A,
EU EMC Directive

3.4. PHYSICAL

7700 or 7701 Frame Mounting:
Number of Slots: 1

4. STATUS INDICATOR LEDS

The 7700ADA-AUD modules have 2 status LED indicators on the card edge of the circuit board to show operational status of the card at a glance (refer to Figure 4-1).

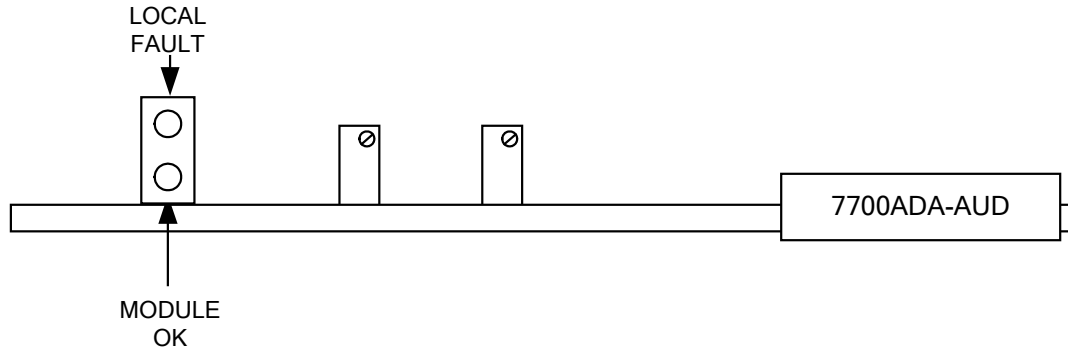

Figure 4-1: LED Status Indicators

Two large LEDs on the front of the board indicate the general health of the module.

LOCAL FAULT: This Red LED indicates poor module health and will be ON if a local input power fault exists (i.e.: a blown fuse). The LOCAL FAULT indication can also be reported to the frame through the FRAME STATUS jumper.

MODULE OK: This Green LED indicates good module health.

5. CARD EDGE CONTROLS

Two trim potentiometers located on the card edge are used to set the gain for each of the channels. Please see section 6.3 for information on how to calibrate the amplifier gain.

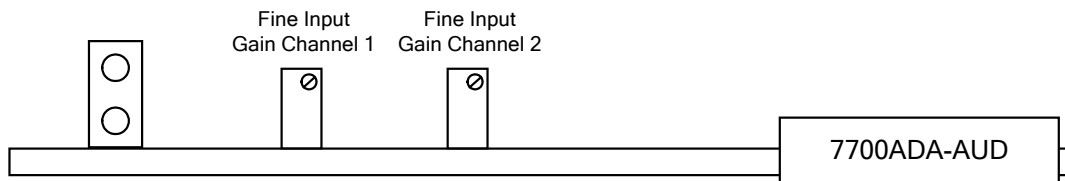

Figure 5-1: Card Edge Controls

6. JUMPERS

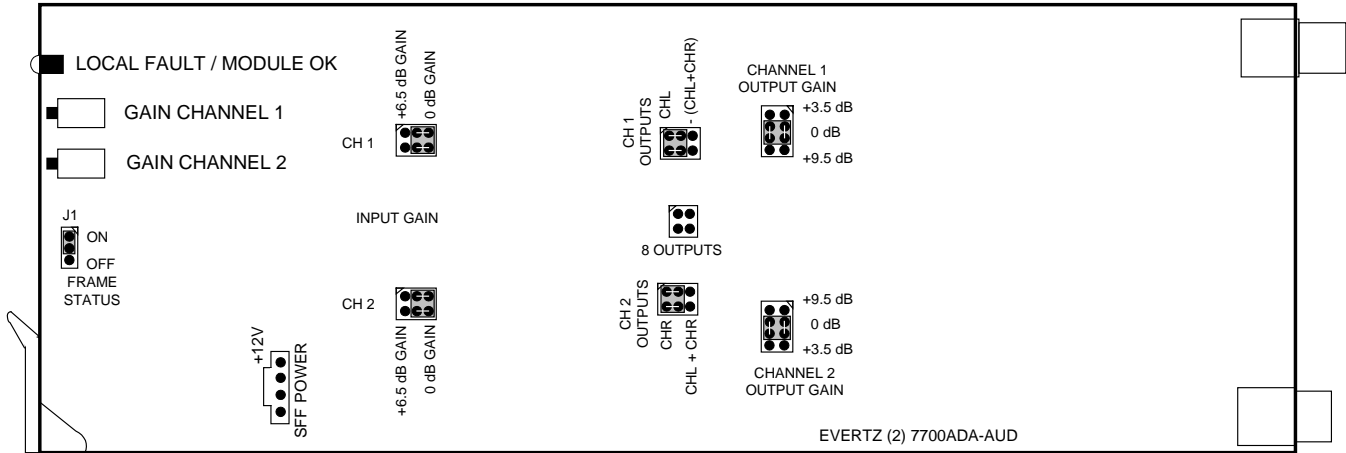

Figure 6-1: Location of Jumpers – PCB Rev 2

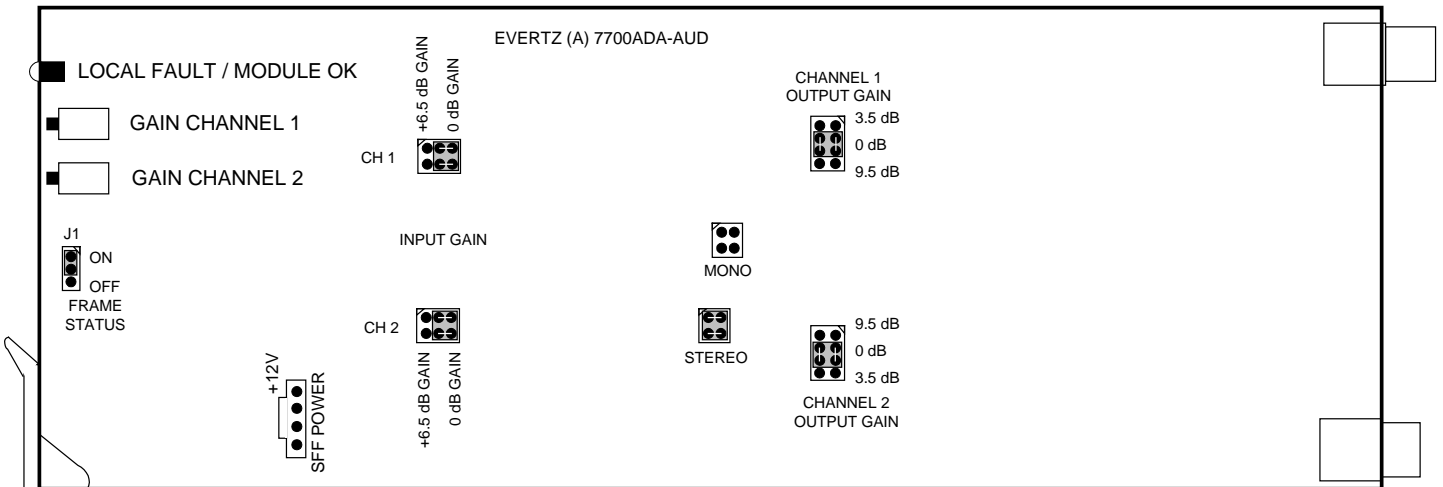

Figure 6-2: Location of Jumpers – PCB Rev A

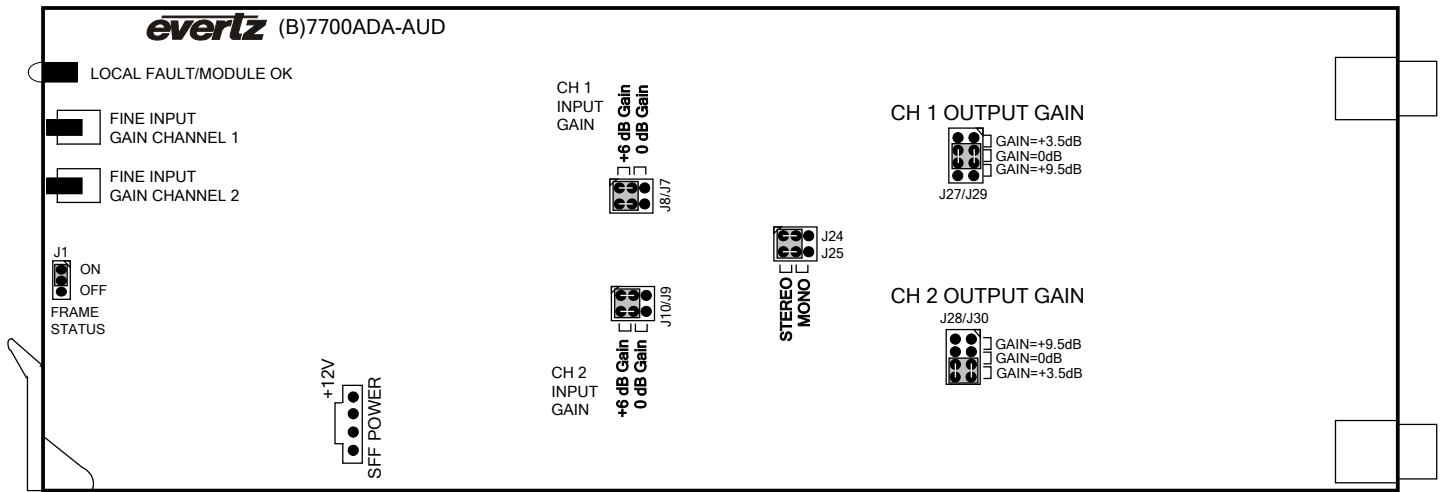

Figure 6-3: Location of Jumpers – PCB Rev B

6.1. SELECTING WHETHER LOCAL FAULTS WILL BE MONITORED BY THE GLOBAL FRAME STATUS

The FRAME STATUS jumper J1 determines whether local faults (as shown by the Local Fault indicator) will be connected to the 7700FR frame's global status bus.

FRAME STATUS: To monitor faults on this module with the frame status indicators (on the Power Supply FRAME STATUS LED's and on the Frame's Fault Tally output) install this jumper in the ON position. (Default)

When this jumper is installed in the OFF position, local faults on this module will not be monitored.

6.2. SETTING THE AMPLIFIER CONFIGURATION

The 7700ADA-AUD can be operated as a single input (monaural) distribution amplifier with 8 outputs or as a dual input (stereo) amplifier with four outputs per input.

On Rev 2 modules there are three jumpers that set the configuration of the amplifier. The dual shorting jumpers provided must be placed on two of the three headers to properly configure the outputs. When placing the jumper, make sure that the brass contacts of the jumpers are oriented as shown in Figure 6-4.

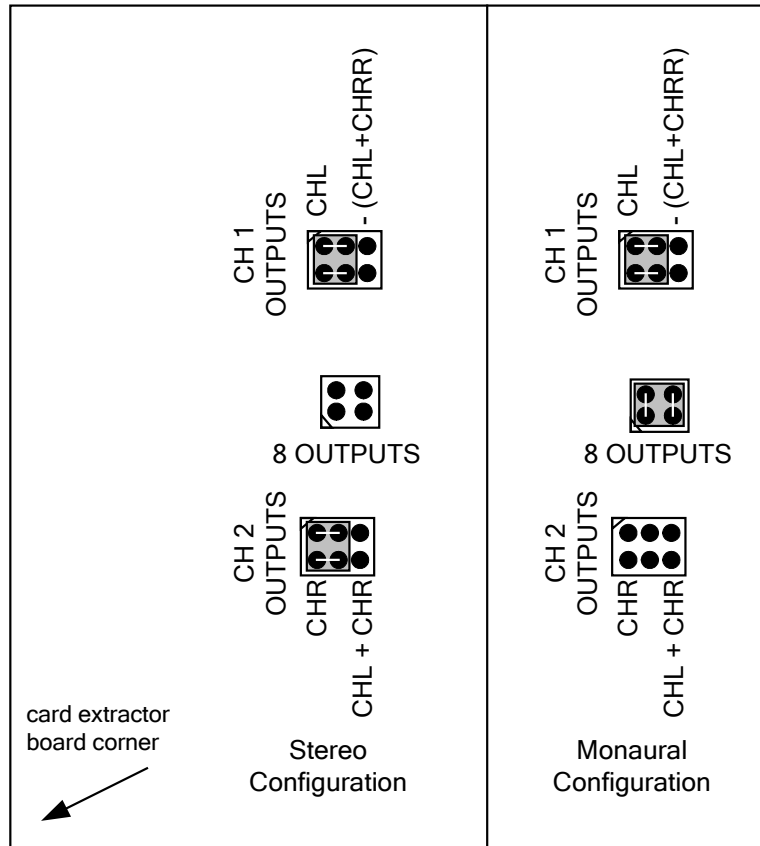

Figure 6-4: Setting the Amplifier Output Configuration – Rev 2

On Rev A modules there are two jumpers that set the configuration of the amplifier. The dual shorting jumpers provided must be placed on one of the two headers to properly configure the outputs. When placing the jumper, make sure that the brass contacts of the jumper are oriented as shown in Figure 6-5.

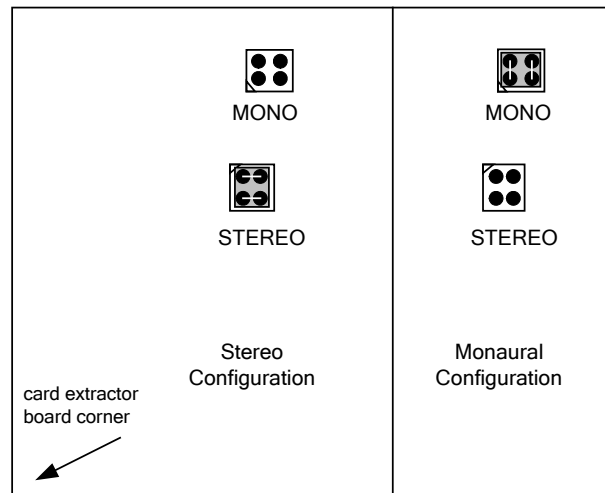

Figure 6-5: Setting the Amplifier Output Configuration – Rev A

On Rev B modules there is one jumper that sets the configuration of the amplifier. The dual shorting jumpers provided must be placed on one of the two headers to properly configure the outputs. When placing the jumper, make sure that the brass contacts of the jumper are oriented as shown in Figure 6-6.

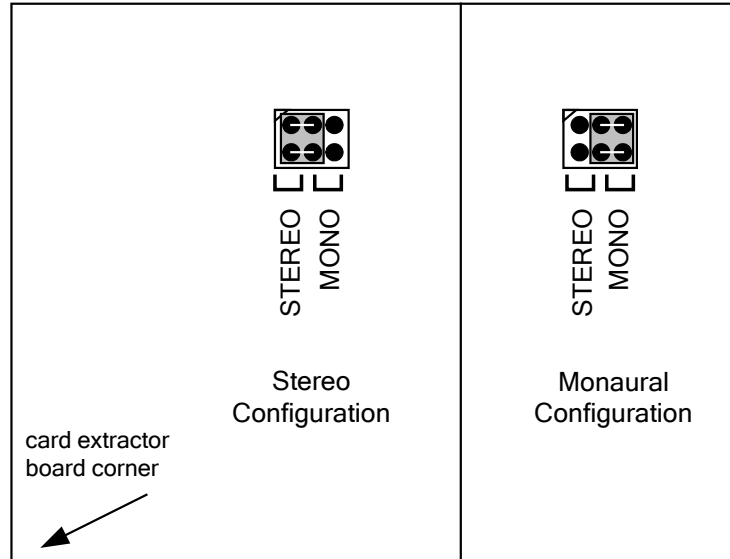

Figure 6-6: Setting the Amplifier Output Configuration – Rev B

6.3. SETTING THE AMPLIFIER GAIN

The overall gain of the 7700ADA-AUD is set in three stages:

- input gain control (2 levels of gain)
- linear (fine-adjust) gain control
- output gain control (3 levels of gain)

Depending on the setup of the input and output gain jumpers, the overall gain can be trimmed with the linear (fine-adjust) gain control within the following ranges:

INPUT GAIN JUMPER SETTING	OUTPUT GAIN JUMPER SETTING	OVERALL GAIN RANGE AVAILABLE WITH THE CARD-EDGE TRIM POT
0 dB	0 dB	-6.5 dB to +9.5 dB
0 dB	+3.5 dB	-3 dB to +13 dB
+6.5 dB	0 dB	0 dB to +16 dB
0 dB	+9.5 dB	+3 dB to +19 dB
+6.5 dB	+3.5 dB	+3.5 dB to +19.5 dB
+6.5 dB	+9.5 dB	+9.5 dB to +25.5 dB

Table 6-1: Amplifier Gain Levels on PCB Rev 2

INPUT GAIN JUMPER SETTING	OUTPUT GAIN JUMPER SETTING	OVERALL GAIN RANGE AVAILABLE WITH THE CARD-EDGE TRIM POT
0 dB	0 dB	-5 dB to +5 dB
0 dB	+3.5 dB	-1.5 dB to +8.5 dB
+6 dB	0 dB	1 dB to +11 dB
0 dB	+9.5 dB	+4.5 dB to +14.5 dB
+6 dB	+3.5 dB	+4.5 dB to +14.5 dB
+6 dB	+9.5 dB	+10.5 dB to +20.5 dB

Table 6-2: Amplifier Gain Levels on PCB Rev B and PCB Rev A

The following sections describe how to set each of the gain stages.

6.3.1. Setting the Input Gain Level

There is one set of jumpers that set the gain for each of the input channels. When the amplifier is configured as a monaural amplifier, (refer to section 6.2) the jumpers for channel 1 set the input gain. Each set of jumpers consist of one 6 pin header. The dual shorting jumper provided can be placed in one of the two locations to select different input gain levels. When placing the jumper, make sure that the brass contacts of the jumper are oriented as shown in Figure 6-7 and Figure 6-8.

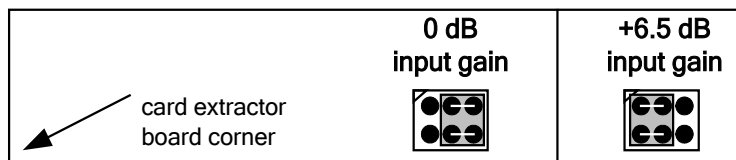

Figure 6-7: Setting the Input Gain Level on PCB Rev 2

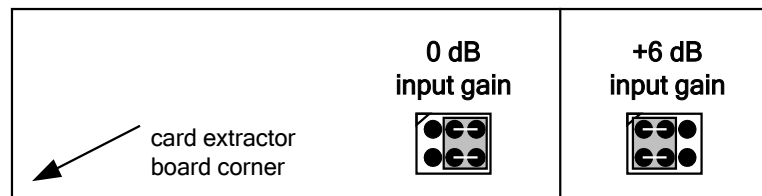

Figure 6-8: Setting the Input Gain Level on PCB Rev B and PCB Rev. A



On PCB Revision A cards newer than November 2002 the text around the input gain jumpers reads +6.5dB but the actual adjustment is +6.0dB.

6.3.2. Setting the Output Gain Level

There are two 8 pin headers that are used to set the output gain levels for the four channel 1 and 2 outputs. Each jumper sets the output levels for the respective four outputs regardless of the amplifier configuration jumper settings. The dual shorting jumper provided can be placed in one of three locations to select different output gain levels. When placing the jumper, make sure that the brass contacts of the jumper are oriented as shown in Figure 6-9.

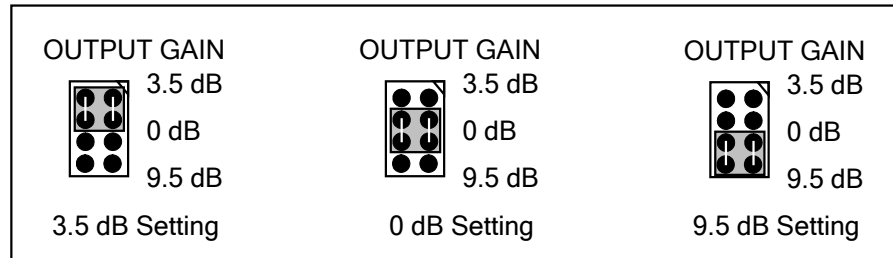

Figure 6-9: Setting the Output Gain Level

6.3.3. Fine-Tuning the Gain Level

There are two trim potentiometers located at the front edge of the card that are used to fine-tune the input gain levels for channel 1 and 2. On 7700ADA-AUD PCB Rev 2 and PCB Rev A modules, the gain increases when the pot is turned counter-clockwise. On 7700ADA-AUD PCB Rev B or later modules, the gain increases when the pot is turned clockwise.

This page left intentionally blank