

TABLE OF CONTENTS

1.	OVERVIEW.....	1
2.	INSTALLATION.....	2
3.	SPECIFICATIONS.....	3
3.1.	ANALOG VIDEO INPUT.....	3
3.2.	ANALOG VIDEO OUTPUTS	3
3.3.	ELECTRICAL	4
3.4.	PHYSICAL.....	4
4.	STATUS LEDS.....	5
5.	CIRCUIT DESCRIPTION.....	6
6.	JUMPERS AND USER ADJUSTMENTS.....	7
6.1.	SELECTING WHETHER LOCAL FAULTS WILL BE MONITORED BY THE GLOBAL FRAME STATUS.....	7
6.2.	SELECTING THE INPUT TERMINATION.....	7
6.3.	SELECTING THE INPUT AC/DC COUPLING	7
6.4.	DC RESTORING (CLAMP) OPERATION	8
6.5.	GAIN ADJUSTMENT.....	8
6.6.	CABLE EQUALIZATION OPERATION	9

Figures

Figure 1-1:	7700ADA6-EQ-L Block Diagram	1
Figure 2-1:	7700ADA7-EQ Rear Panel	2
Figure 6-1:	LED and Jumper Locations	7

REVISION HISTORY

<u>REVISION</u>	<u>DESCRIPTION</u>	<u>DATE</u>
1.0	Original Version	May 2007
1.1	Updated block diagram	Oct 2007
1.2	Updated specifications. General format clean up.	May 2010

Information contained in this manual is believed to be accurate and reliable. However, Evertz assumes no responsibility for the use thereof nor for the rights of third parties, which may be affected in any way by the use thereof. Any representations in this document concerning performance of Evertz products are for informational use only and are not warranties of future performance, either expressed or implied. The only warranty offered by Evertz in relation to this product is the Evertz standard limited warranty, stated in the sales contract or order confirmation form.

Although every attempt has been made to accurately describe the features, installation and operation of this product in this manual, no warranty is granted nor liability assumed in relation to any errors or omissions unless specifically undertaken in the Evertz sales contract or order confirmation. Information contained in this manual is periodically updated and changes will be incorporated into subsequent editions. If you encounter an error, please notify Evertz Customer Service department. Evertz reserves the right, without notice or liability, to make changes in equipment design or specifications.

1. OVERVIEW

The Evertz 7700ADA6-EQ-L is an equalizing 1x6 Analog Distribution Amplifier. The 7700ADA6-EQ-L features one balanced equalized input, one passive looping output and six outputs. The module has been designed to distribute a wide range of analog video signals. It can also distribute other pulses and signals that are less than 2Vp-p.

The 7700ADA6-EQ-L occupies one card slot in the 3RU frame, which will hold up to 15 modules or the 1RU frame, which will hold up to three modules.

Features:

- Passive loop thru
- Gain Control
- High common mode range and common mode rejection ratio (CMMR)
- Jumper selectable AC or DC coupling
- Jumper selectable fast or slow back porch clamp
- DC level control when clamp is enabled
- Cable equalizer adjustment range: 0 to 300m of 8281 or 1694AA
- Consistent input impedance if card power is lost
- Module Status/Local Fault

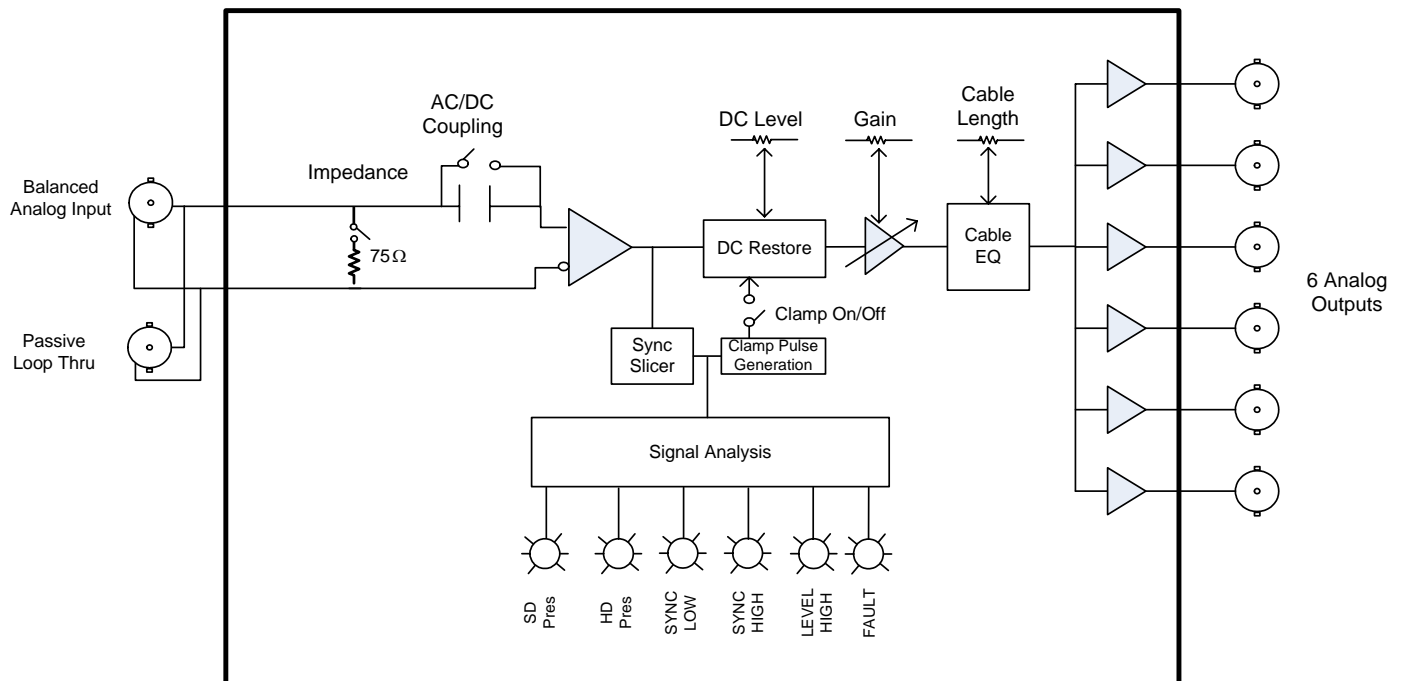

Figure 1-1: 7700ADA6-EQ-L Block Diagram

2. INSTALLATION

The 7700ADA6-EQ-L comes with a companion rear panel overlay that can be placed over the rear panel BNC connectors to identify their function. For information on inserting the module into the frame see section 3 of the 7700FR chapter.

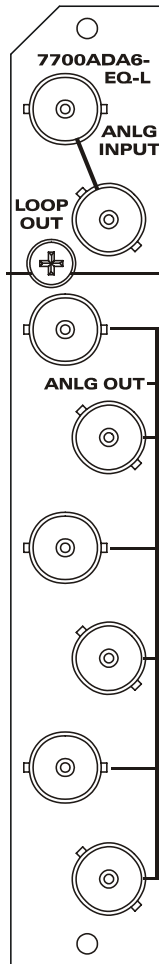

Figure 2-1: 7700ADA7-EQ Rear Panel

- IN:** Input (isolated) BNC connector for analog video signals.
- LOOP OUT:** Passive loop thru of input signal.
- OUT 1 to 6:** There are six BNC connectors with equalized, level and DC adjusted copies of the input signal.

3. SPECIFICATIONS



Note: At the time of printing, this product has only been qualified for use with standard definition signals. It, however, has been designed to work with high definition signals. Frequency, phase response as well as cable equalization will not be optimized at the upper frequency range of high definition video bandwidths.

All specifications, unless indicated, are measured under the following conditions:

- 1 Vp-p video applied
- 75 Ohm card input terminated
- AC coupled
- DC restore clamp turned on with slow time constant
- DC level adjusted for blanking at 0V
- Gain adjusted for unity operation into 75 Ohm load
- Cable equalizer set to 0 length

3.1. ANALOG VIDEO INPUT

Standards:	Any analog video format, up to 2Vp-p and 30MHz bandwidth
Connector:	BNC per IEC 61169-8 Annex A
Common Mode Range:	>6Vp-p
CMRR:	> 70dB to 1kHz
Signal Amplitude:	2.5Vp-p max
Cable Equalizer:	0 to 300m of Belden 8281 or 1694AA cable
Coupling:	AC or DC (jumper selectable)
Return Loss:	>40dB to 10MHz, >30dB to 30MHz
Clamp Range:	+/- 600mV
Fast Clamp	
Attenuation of 60Hz:	>36dB

3.2. ANALOG VIDEO OUTPUTS

Passive Loop:	1
Number of Outputs:	6 Per Card
Connector:	BNC per IEC 61169-8 Annex A
Output Impedance:	75Ω
Gain Control Range:	± 5dB
DC Level:	< ± 100mV (with DC Coupling active and back porch clamp disabled)
Freq. Response:	<±0.05dB (to 5.5MHz)
Differential Gain:	<0.17 % 0 to 300m
Differential Phase:	< 0.19 deg 0 to 300m
C/L gain inequality:	<±0.1% for all cable lengths
C/L Delay:	<±2nsec
Output Isolation:	42dB to 10MHz, 32 dB to 30MHz
Output Return Loss:	>40dB to 30MHz
Noise Performance:	<-78dB RMS NTC7 weighting, <-70dB RMS 15kHz to 5.5MHz

3.3. ELECTRICAL

Voltage: + 12VDC
Power: 1.2 Watts
EMI/RFI: Complies with FCC Part 15, Class A, EU EMC Directive

3.4. PHYSICAL

Number of Slots: 1

4. STATUS LEADS

The 7700ADA6-EQ-L has seven LED Status indicators on the front card edge to show operational status of the card at a glance. Figure 6-1 shows the location of the LEDs.

Two large LEDs on the front of the board indicate the general health of the module.

LOCAL FAULT: This Red LED indicates poor module health and will be On during the absence of a valid input signal, or if a local input power fault exists (i.e.: a blown fuse). The LOCAL FAULT indication can also be reported to the frame through the FRAME STATUS jumper.

MODULE OK: This Green LED indicates good module health. It will be On when a valid input signal is present, and the board power is good.

There are five small LEDs that indicate the status of the input video.

SD/HD Video Presence Indicators:

The width of sync is measured to determine if video is present and if it is NTSC/PAL-B or if it is analog high definition video. If sync is approximately 4.7 μ sec wide, the green **SD PRES** LED is illuminated. If sync is approximately 0.6 μ sec wide, the green **HD PRES** LED is illuminated. If neither sync size is present, both LEDs are turned off.

This technique will also successfully detect HD signals with bi-level sync generated by Evertz DACs for applications with computer monitors. Other manufacturers DACs may not have the same sync size so the detection may not work with these signals.

Sync High/Low Indicators:

The sync level of the processed video is measured to determine if its amplitude is approximately correct. If sync is below 270mV then the amber **SYNC LOW** LED is turned on and if sync is above 320mV then the amber **SYNC HIGH** LED is turned on. This measurement takes place AFTER all of the card processing. This means that if the card is not calibrated properly, the indicators will not represent the proper state of the video. This includes improper setting of restored DC level, poorly equalized video and wrong gain settings.



These indicators will NOT indicate properly when the input video is AC coupled and the DC restore clamp is turned off.

Video High Indicator:

The level of the processed video is measured to determine if its amplitude is approaching the 100% level. If in one field, the video is ever above 700mV then the amber **VIDEO HIGH** LED is turned on for a short duration. If the video is consistently too "hot", then the light will always be on. This measurement takes place AFTER all of the card processing. This means that if the card is not calibrated properly, the indicator will not represent the proper state of the video. This includes improper setting of restored DC level, poorly equalized video and wrong gain settings.



These indicators will NOT indicate properly when the input video is AC coupled and the DC restore clamp is turned off.

5. Circuit Description

The input signal enters the board through a BNC with isolated ground so that balanced input processing may be done to remove any common mode hum that may have been added to the signal and ground shield. On-board jumpers allow you to configure the input impedance and input coupling (AC/DC).

For video applications, the synchronization pulses are analyzed for position and size information. A clamp pulse is generated from the sync information and a clamp signal is delivered to a DC restorer circuit that positions the blanking level to ground. This feature can be enabled with a jumper. The time-constant of the clamping action may be fast or slow and the DC level may be set with a card edge POT.

An adjustable gain stage feeds the cable equalizer that can adjust the frequency response to match the attenuation of up to 300m of coaxial cable. Three separate OP-Amps drive the nine output BNC's with 75-Ohm output impedance.

6. JUMPERS AND USER ADJUSTMENTS

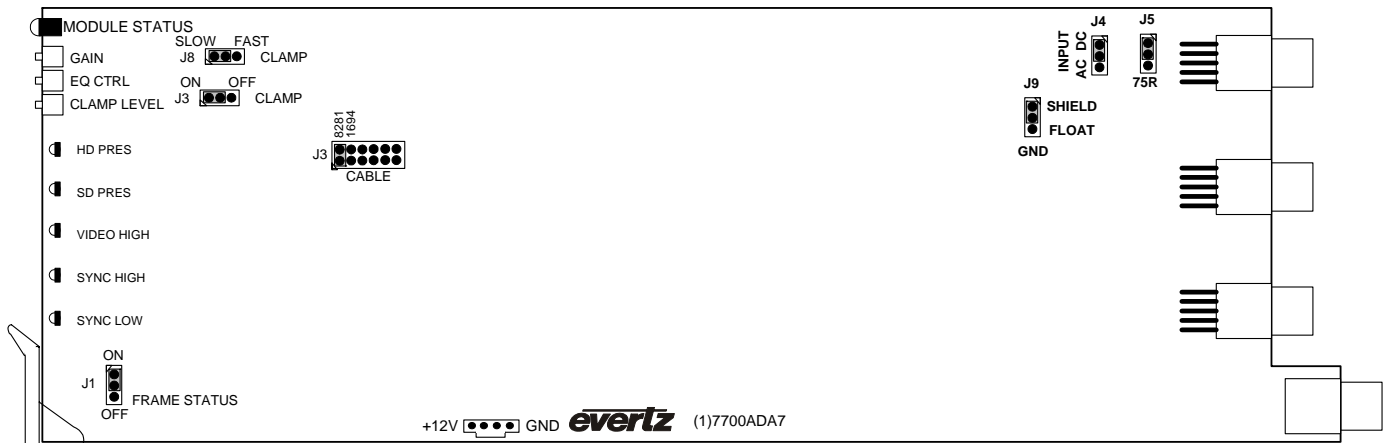

Figure 6-1: LED and Jumper Locations

6.1. SELECTING WHETHER LOCAL FAULTS WILL BE MONITORED BY THE GLOBAL FRAME STATUS

The FRAME STATUS jumper J1, located at the front of the module, determines whether local faults (as shown by the Local Fault indicator) will be connected to the 7700FR frame's global status bus.

FRAME STATUS: To monitor faults on this module with the frame status indicators (on the power supply's FRAME STATUS LED's and on the Frame's Fault Tally output) install this jumper in the On position.

When this jumper is installed in the Off position local faults on this module will not be monitored.

6.2. SELECTING THE INPUT TERMINATION

The input termination may be set via card jumper J5 to either 75 Ohms (default) or Hi-Z (34k Ohms). Set it to Hi-Z when using the passive loop thru BNC connector to loop the signal through several device inputs.



To terminate the signal (for non-looping applications), ensure that this jumper (J5) is installed in the 75Ohms position.

6.3. SELECTING THE INPUT AC/DC COUPLING

The input may be AC or DC (default) coupled into the input-circuitry using jumper J4. Use AC coupling in applications when the input signal has a large (>2V) DC level. In some non-video applications that do not have DC information (i.e. digital AES audio), AC coupling can be used to remove any DC level that may have built up in its transmission. The DC Restoring (clamp) circuitry will work with either AC or DC coupling in video applications.

6.4. DC RESTORING (CLAMP) OPERATION

A clamp pulse is generated from the sync information and a clamp signal is delivered to a DC restorer circuit that positions the blanking level to ground. This feature will work with standard definition analog NTSC and PAL-B sync structures. Analog tri-level sync 1125-line high definition video (SMPTE 240M) will also be detected and DC restored. In addition, most versions of bi-level sync that have been applied to 1125-line high definition video will be supported.



The clamp position and size will successfully DC restore HD signals with bi-level sync generated by Evertz DACs for applications with computer monitors. Other manufacturers DACs may not have the same sync size and the DC restoring may not work with these signals.

The clamp action can be enabled with a jumper, the time-constant of the clamping action may be fast or slow and the DC level may be set with a card edge POT. For non-video, applications disable the clamp with the jumper (J7). For removing low frequency distortions (<1kHz) from clean video, use the clamp time-constant (J8) in the FAST position. If the video has a sizeable amount of noise (i.e. a low quality off-air signal) the fast clamp will generate a line-to-line level distortion (also called "piano-keying") because of the noise. In this situation, use the SLOW clamp position of (J8). The **CLAMP LEVEL** POT on the card front edge allows you to adjust the DC level that the back porch is being clamped to. This allows you to set the output DC level to values other than back porch to ground.



Do NOT turn on the clamp when distributing Pb and Pr signals. Standard Definition and High Definition component Pb and Pr signals have waveforms that extend below blanking level. The right level and duration of a negative going video signal may be interpreted as a sync signal, enabling a clamp pulse in active video. This will cause the DC restorer circuit to distort the video, creating a large Average Picture Level (APL) change.

6.5. GAIN ADJUSTMENT

The **GAIN** POT on the cards front edge allows you to adjust the input signal level. Turning the POT clockwise will increase the gain.



There is enough range on this control to counteract the video level error due to a missing or double terminated coaxial connection. This will create a frequency response problem due to the mis-termination.

TIP: Set the DC LEVEL before adjusting the gain. The Gain control amplifies the signal around ground. By setting the back porch to ground first, you may avoid re-adjusting the gain.

6.6. CABLE EQUALIZATION OPERATION

With the cable equalizer **EQCTRL** POT set fully counter-clockwise, the cable equalizer will be set to the "zero length". As you turn the POT clockwise, more cable equalization is added. To set the POT to the correct position, perform the following calibration:

1. Supply the cable being equalized with a multiburst or horizontal sweep test signal.
2. Make sure the driving level from the test generator is calibrated to unity.
3. Set the cable type termination jumper (J6) to the type of cable you are using (either 8281 or 1694). If you are using a different type, then use either setting.
4. Make sure the card input termination and the test gear is terminated properly.
5. Adjust the DC level if the clamp is enabled and calibrate the GAIN level POT for unity output at low frequencies.
6. Adjust the "EQCTRL" POT until the 7700ADA7 output signal has flat frequency response.

This page left intentionally blank