TABLE OF CONTENTS

1.	OVERVIEW.....	1
2.	INSTALLATION.....	4
2.1.	ETHERNET CONNECTIONS	4
2.2.	OPTICAL CONNECTIONS	5
2.2.1.	Single Fiber version	5
2.2.2.	Standard Dual Fiber Version (-F2 version).....	6
2.3.	CARE AND HANDLING OF OPTICAL FIBER.....	6
2.3.1.	Safety	6
2.3.2.	Assembly.....	6
2.3.3.	Labeling.....	7
2.3.4.	Handling and Connecting Fibers	7
3.	SPECIFICATIONS.....	8
3.1.	ETHERNET INPUT/OUTPUT	8
3.2.	OPTICAL INPUT/OUTPUT	8
3.3.	ELECTRICAL	8
3.4.	PHYSICAL.....	9
4.	STATUS INDICATORS AND DISPLAYS	10
4.1.	STATUS INDICATOR LEDES.....	10
4.1.1.	Module Health LEDs	10
4.1.2.	Fiber Link LED	10
4.1.3.	Card Edge Ethernet LEDs.....	10
4.1.4.	Rear Panel Ethernet LEDs.....	11
4.2.	DOT-MATRIX DISPLAY	11
4.2.1.	STATUS MENU SELECTIONS.....	12
4.2.1.1.	Displaying Optical Power	12
4.2.1.2.	Displaying the Firmware Version	12
4.2.2.	CONTROL MENU SELECTIONS	12
4.2.2.1.	Jumbo Frame Control	12
4.2.2.2.	Setting the Orientation of the Text on the Card Edge Display	13
5.	JUMPERS AND USER ADJUSTMENTS.....	14
5.1.	SELECTING WHETHER LOCAL FAULTS WILL BE MONITORED BY THE GLOBAL FRAME STATUS	14

5.2. CONFIGURING THE MODULE FOR FIRMWARE UPGRADES	15
5.3. SELECTING THE CARD ADDRESS (SINGLE FIBER VERSION ONLY)	15
6. VISTALINK® REMOTE MONITORING/CONTROL	16
6.1. WHAT IS VISTALINK®?	16
6.2. VISTALINK® CONTROLLED PARAMETERS	16
6.3. VISTALINK® MONITORED PARAMETERS	17

Figures

Figure 1-1: 7708GT Block Diagram	3
Figure 1-2: 7708GT-F2 Block Diagram	3
Figure 2-1: 7708GT Rear panels	4
Figure 2-2: Reproduction of Laser Certification and Identification Label	7
Figure 5-1: LED and Jumper Locations	14

Tables

Table 1-1: Typical Application Configurations	2
Table 2-1: Ethernet Connector Pin Definitions and Cable Wiring for 1000 Base-T	5
Table 4-1: Dot Matrix Display Menu Selection Items	11
Table 6-1: VistaLINK® Controlled Parameters	16
Table 6-2: VistaLINK® Monitored Parameters	17

REVISION HISTORY

<u>REVISION</u>	<u>DESCRIPTION</u>	<u>DATE</u>
1.0	First release version	Mar 2009
1.1	Updated Figure 5-1 LED information and Rear Plate Drawing	Feb 2010

Information contained in this manual is believed to be accurate and reliable. However, Evertz assumes no responsibility for the use thereof nor for the rights of third parties, which may be affected in any way by the use thereof. Any representations in this document concerning performance of Evertz products are for informational use only and are not warranties of future performance, either expressed or implied. The only warranty offered by Evertz in relation to this product is the Evertz standard limited warranty, stated in the sales contract or order confirmation form.

Although every attempt has been made to accurately describe the features, installation and operation of this product in this manual, no warranty is granted nor liability assumed in relation to any errors or omissions unless specifically undertaken in the Evertz sales contract or order confirmation. Information contained in this manual is periodically updated and changes will be incorporated into subsequent editions. If you encounter an error, please notify Evertz Customer Service department. Evertz reserves the right, without notice or liability, to make changes in equipment design or specifications.



Never look directly into an optical fiber. Non-reversible damage to the eye can occur in a matter of milliseconds.



Do not hook up the 7708GT DWDM cards directly with a short fiber optic cable. The 7708GT DWDM cards produce +7dBm of power, which will damage the receiver if connected directly.

1. OVERVIEW

The 7708GT series Gigabit Ethernet Fiber Transceivers provide an economical method of transmitting 10/100/1000Base-T Ethernet channel over optical fiber. The transceiver is IEEE 802.3 10BASE-T, IEEE 802.3u 100BASE-TX and IEEE 802.3ab 1000BASE-TX compliant, mediates between a 10/100/1000BASE-TX segment. A pair of 7708GT transceivers permits full duplex communication over a single optical fiber or dual fiber. There is also a built in two port gigabit Ethernet switch that supports a total bandwidth of 1000Mbps. Diagnostic LEDs provide indication of power, linkage and data reception. The 7708GT series modules support jumbo frames and spanning tree protocol.

Features:

- Auto negotiation for 10/100/1000 speeds, half/full duplex modes
- Link status monitoring indicators
- Optional VistaLINK[®] enabled for remote monitoring and control
- Optical output available in 1310nm, 1550nm and up to sixteen CWDM wavelengths in the 1270nm to 1610nm range
- DWDM (ITU-T G.694.1) wavelengths available
- Supports multi-mode or single-mode fiber
- Fully hot-swappable from front of frame with no fiber or Ethernet channel disconnect required
- SC/PC, ST/PC or FC/PC connector options
- Jumbo frame support
- Spanning tree protocol support

Two versions of the 7708GT allow the user to choose the optimal price / performance / features to suit a particular application. The “-F2” version is designed to receive and transmit over two different fibers and has the lowest insertion loss. This version can operate with Multi-mode or Single-mode fiber. The single fiber version (-W) is designed to receive and transmit on two different wavelengths (1310nm and 1550nm) over a single fiber and can operate with Single mode fiber only.

Model	Optical Configuration
7708GT-W	Single Fiber
7708GT-F2	Dual Fiber

Each version of the 7708GT is available with different output laser options to meet a variety of applications. (See the specifications in section 3 for complete information):

7708GT13M-W	1310 nm FP Laser
7708GT15-W	1550 nm DFB Laser

There are sixteen wavelengths with built-in isolators specifically suited to coarse wave-division multiplexing (CWDM) applications.

7708GT27-F2	1270 nm DFB
7708GT29-F2	1290 nm DFB
7708GT31-F2	1310 nm DFB
7708GT33-F2	1330 nm DFB
7708GT35-F2	1350 nm DFB
7708GT37-F2	1370 nm DFB
7708GT43-F2	1430 nm DFB

7708GT45-F2	1450 nm DFB
7708GT47-F2	1470 nm DFB
7708GT49-F2	1490 nm DFB
7708GT51-F2	1510 nm DFB
7708GT47-F2	1530 nm DFB
7708GT47-F2	1550 nm DFB
7708GT47-F2	1570 nm DFB
7708GT47-F2	1590 nm DFB
7708GT47-F2	1610 nm DFB

The following chart shows some typical applications and power budget calculations.

Fiber Type	Fiber Links	Optical/Link Budget	Transmit Side		Receive Side		Description
			Ordering Product Info	TX Power	Ordering Product Info	RX Sensitivity	
Multi-Mode	2	< 1km	7708GT13-F2	-7dBm	7708GT13-F2	-23dBm	1310nm on Tx & Rx fibers
Single-Mode	2	16dB/45km	7708GT13-F2	-7dBm	7708GT13-F2	-23dBm	1310nm on Tx & Rx fibers
Single-Mode	1	10dB/28km*	7708GT13	-9dBm	7708GT13	-19dBm	1310nm, bi-directional, one fiber
Single-Mode	1(WDM)	20dB/57km	7708GT13L-W	-1dBm	7708GT15-W	-21dBm	1310nm/1550nm, WDM, bi-directional on one fiber
Single-Mode	1(CWDM)	19dB/76km**	7708GTxx-F2	0dBm	7708GTyy-F2	-23dBm	Difference CWDM wavelengths on Tx & Rx, with 8 channel CWDM Mux/Demux**
Single-Mode	1(CWDM)	24dB/96km**	7708GTxx-F2-H	0dBm	7708GTyy-F2-H	-28dBm	Different CWDM wavelengths on Tx & Rx, with 8 channel CWDM Mux/Demux**
Single-Mode	1(DWDM)	25dB/100km***	7708GTDxxx-F2	+7dBm	7708GTDyyy-F2	-23dBm	Different DWDM wavelengths on Tx & Rx, with 8 channel DWDM Mux/Demux***
Single-Mode	1(DWDM)	30dB/120km***	7708GTDxxx-F2-H	+7dBm	7708GTDyyy-F2-H	-28dBm	Different DWDM wavelengths on Tx & Rx, with 8 channel DWDM Mux/Demux***

*With >20dB return loss on fiber Interface
**Assume 8Ch CWDM Mux/Demux loss of 3.5dB
***Assumes 8Ch DWDM Mux/Demux loss of 5dB

Tx Power/Rx Sensitivity are nominal values
Fiber Loss = 0.35/0.25dB per km @ 1310nm/

Table 1-1: Typical Application Configurations

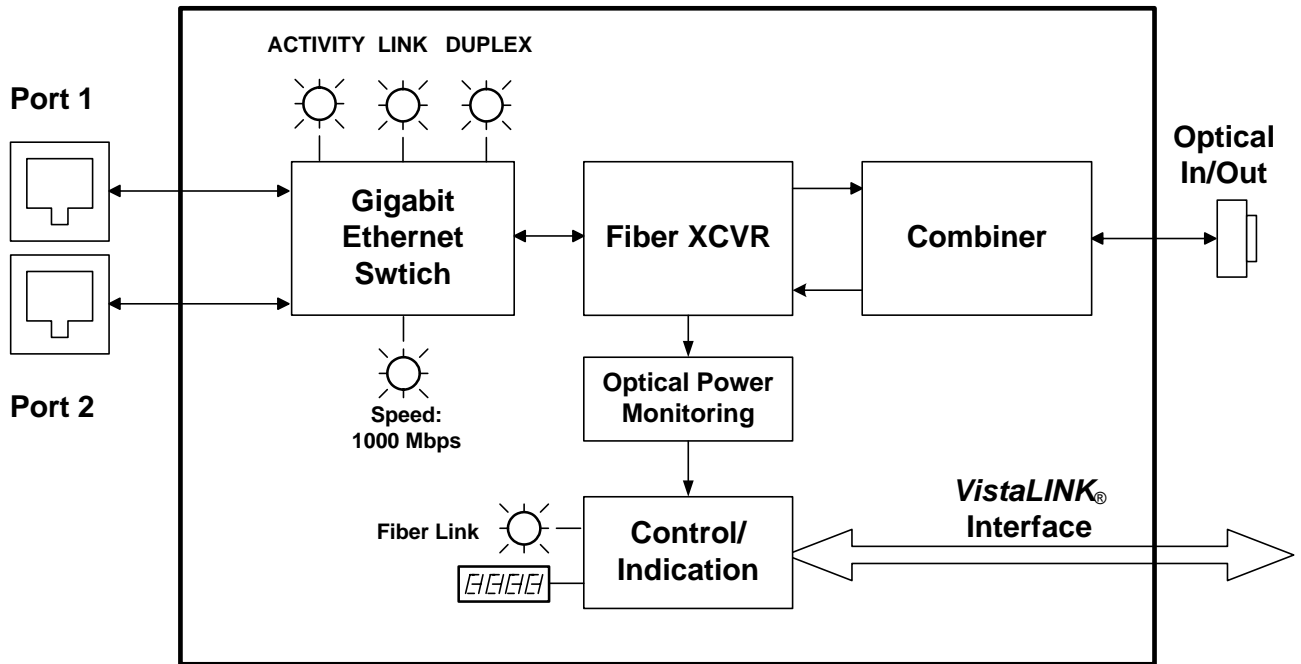

Figure 1-1: 7708GT Block Diagram

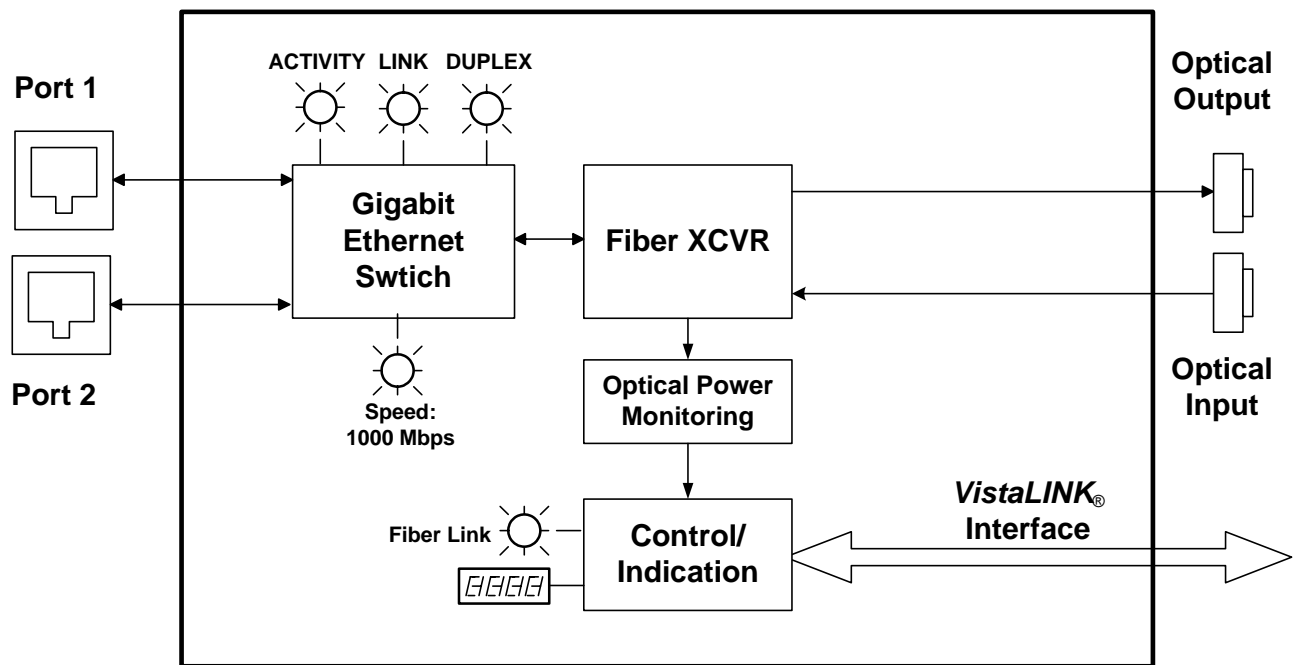

Figure 1-2: 7708GT-F2 Block Diagram

2. INSTALLATION

The single fiber 7708GT modules come with a companion rear plate that has two RJ-45 input connectors and one SC/PC (shown), ST/PC or FC/PC optical connector. The dual fiber versions come with a companion rear plate that has two RJ-45 input connectors and two SC/PC, ST/PC or FC/PC optical connectors. For information on mounting the rear plate and inserting the module into the frame see section 3 of the 7700FR chapter.

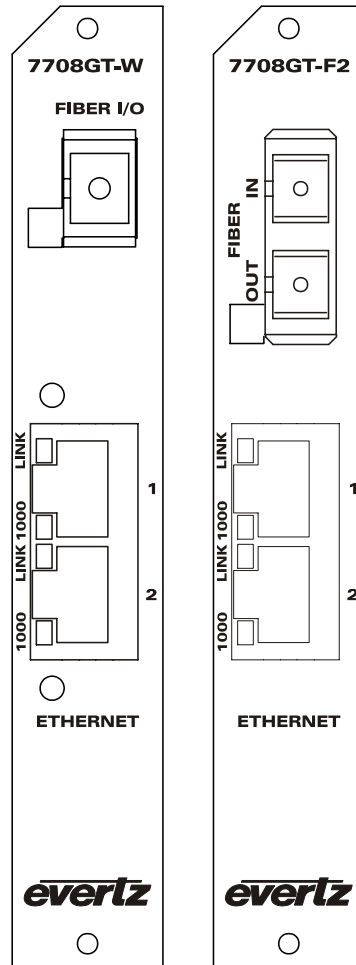

Figure 2-1: 7708GT Rear panels

2.1. ETHERNET CONNECTIONS

The RJ-45 connectors on the rear panel are for connection to network devices (server, workstation, router switch, etc.) with a 10/100/1000BASE-TX port through a twisted pair cable.

The 7708GT Gigabit Ethernet Transceiver is designed for use with 1000Base-TX twisted pair Ethernet cabling systems. When connecting for 1000Base-TX systems, category 5 UTP cable is required. The maximum cable run between the Gigabit Ethernet Fiber Transceiver and the supporting device is 100 m. Make the network connection by plugging one end of the cable into the RJ-45 receptacle of the Gigabit Ethernet Fiber Transceiver and the other end into a port of the supporting device.

Table 2-1 shows the cable connections required for 1000Base-T systems.

Pin #	Name	Cable Pair	Description
1	Tx/Rx1+	-----1a-----	Transmit/Receive 1 + Output
2	Tx/Rx1-	-----1b-----	Transmit/Receive 1 – Output
3	Tx/Rx2+	-----2a-----	Transmit/Receive 2 + Output
4	Tx/Rx2-	-----2b-----	Transmit/Receive 2 – Output
5	Tx/Rx3+	-----3a-----	Transmit/Receive 3 + Output
6	Tx/Rx3-	-----3b-----	Transmit/Receive 3 – Output
7	Tx/Rx4+	-----4a-----	Transmit/Receive 4 + Output
8	Tx/Rx4-	-----4b-----	Transmit/Receive 4 – Output

Table 2-1: Ethernet Connector Pin Definitions and Cable Wiring for 1000 Base-T

Devices on the Ethernet network continually monitor the receive data path for activity as a means of checking that the link is working correctly. When the network is idle, the devices also send a carrier signal to one another to maintain the link. The 7708GT rear panel is fitted with two LEDs on each RJ-45 connector to monitor the Ethernet connection on each port.

1000: This Green LED is On when a 1000Base-TX link is established. The LED is Off when a 10Base-T or 100Base-Tx link is established (the LINK LED is On) or if there is no link established (the LINK LED is Off). This LED should show the same information as the **Speed 1G** LED on the card edge.

LINK: This dual purpose Green LED indicates that the 7708GT has established a valid link, and whether the 7708GT is sending or receiving data on the respective Ethernet port. The LED will be On when the 7708GT has established a good link, providing a good indication that the segment is wired correctly. The LED will BLINK when the 7708GT is sending or receiving data. The LED will be Off if there is no valid connection.

2.2. OPTICAL CONNECTIONS



The 7708GT modules are designed to work with single-mode or multi-mode optical fiber depending on the version ordered.

2.2.1. Single Fiber version



In order to establish a valid link between a pair of single fiber 7708GT modules, one module must be configured as 'Address A', and the other as 'Address B'. Selection of the correct address is achieved by setting jumper J6. See section 5.3.

FIBER I/O: There is one SC/PC (shown), SC/PC with cover flap, ST/PC or FC/PC female connector with the optical input/output from the 7708GT. This connector should be connected to the matching connector of a matching single fiber 7708GT module at the destination end with a suitable fiber optic cable.

All single fiber versions of the 7708GT have their associated transmit wavelength marked on the rear panel and are designed to work with single-mode fiber optic cable.

2.2.2. Standard Dual Fiber Version (-F2 version)

FIBER IN: There is one SC/PC (shown), ST/PC or FC/PC female connector with the optical input to the module. This connector should be connected to the FIBER OUT connector of a matching dual fiber 7708GT-F2 module at the destination end with a suitable fiber optic cable. The dual fiber 7708GT-F2 versions receive on wavelengths in the 1270 to 1610nm range.

FIBER OUT: There is one SC/PC (shown), ST/PC or FC/PC female connector with the optical output from the module. This connector should be connected to the FIBER IN connector of a matching dual fiber 7708GT-F2 module at the destination end with a suitable fiber optic cable. The dual fiber 7708GT-F2 versions transmit on the wavelength marked on the rear panel and are designed to work with either single-mode or multi-mode fiber optic cable.

Optical input powers above -7dBm can physically damage the optical receiver. For normal use of the device in a long haul application (exceeding 7dBm optical loss) this is not an issue. However to help prevent this type of damage during setup, a mechanism built into the cards will protect them if an input power over -7dBm is detected at the input of either of the cards. If an input of greater than -7dBm is detected at the input to either of the cards in a link, both cards will take the following action:

- The optical output will be shut down.
- The dot matrix display will show **ovR**.
- The red local fault LED will be turned on.

Once the input optical power has been restored to $\leq -7\text{dBm}$ on both cards normal operation can be restored. To restore normal operation either one of the cards must be powered off and then powered on. This can be done by removing a card from the frame and putting it back in or by powering the frame off and back on again.

2.3. CARE AND HANDLING OF OPTICAL FIBER

2.3.1. Safety



Background colour: yellow
Triangular band: black
Symbol: black

CLASS 1 LASER PRODUCT

2.3.2. Assembly

Assembly or repair of the laser sub-module is done only at Evertz facility and performed only by qualified Evertz technical personnel.

2.3.3. Labeling

Certification and Identification labels are combined into one label. As there is not enough room on the product to place the label it is reproduced here in the manuals.

- There is no date of manufacture on this label as it can be traced by bar code label placed on the Printed circuit board of each Evertz plug-in module
- The Model number is one of: 7708GT-13, 7708GT13L-W, 7708GT15-W, 7708GT13-F2
- 7708GTxx (xx = 27, 29, 31, 33, 35, 37, 43, 45, 47, 49, 51, 53, 55, 57, 59, 61)
7708GTDyyy (Dyyy represents ITU Grid Channel: D200, D210, D220, D230, D240, D250, D260, D270, D280, D290, D300, D310, D320, D330, D340, D350, D360, D370, D380, D390, D400, D410, D420, D430, D440, D450, D460, D470, D480, D490, D500, D510, D520, D530, D540, D550, D570, D580, D590, D600)

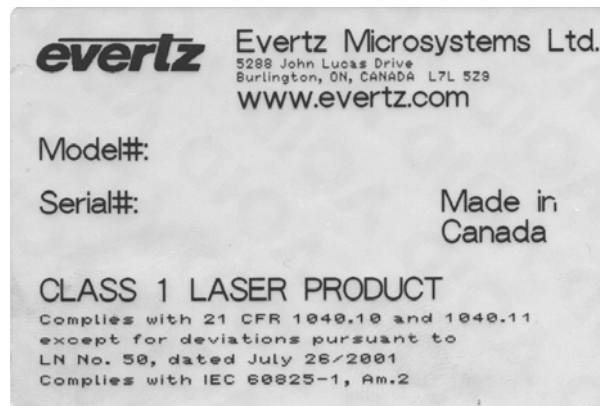

Figure 2-2: Reproduction of Laser Certification and Identification Label

2.3.4. Handling and Connecting Fibers



Never touch the end face of an optical fiber. Always keep dust caps on optical fiber connectors when not connected and always remember to properly clean the optical end face of a connector before making a connection.

The transmission characteristics of the fiber are dependent on the shape of the optical core and therefore care must be taken to prevent fiber damage due to heavy objects or abrupt fiber bending. Evertz recommends that you maintain a minimum bending radius of 5 cm to avoid fiber-bending loss that will decrease the maximum attainable distance of the fiber cable. The Evertz fiber optic modules come with cable lockout devices, to prevent the user from damaging the fiber by installing a module into a slot in the frame that does not have a suitable I/O module. For further information about care and handling of the fiber optic cable see section 3 of the Fiber Optics System Design section of this manual binder.

3. SPECIFICATIONS

3.1. ETHERNET INPUT/OUTPUT

Standard:	IEEE 802.3 10BASE-T, 802.3u 100BASE-TX, 802.3ab 1000BASE-TX - auto-negotiation 10/100/1000Mbps
Connector:	2 x RJ-45
Cable Requirements:	
10BASE-T:	UTP category 3, 4, or 5 cable up to 328 ft/100m (2 Pairs)
100BASE-TX:	UTP category 5 cable up to 328 ft/100m (2 pairs)
1000BASE-TX:	UTP category 5 cable up to 328 ft/100m (4 pairs)

3.2. OPTICAL INPUT/OUTPUT

Connector:	
Single Fiber version:	1 Bi-directional optical connector: SC/PC, ST/PC or FC/PC female housing
Dual Fiber (F2) version:	2 optical connector: SC/PC, ST/PC or FC/PC female housing
Maximum Input Power:	
Standard Sensitivity Receiver:	-1 dBm
High sensitivity versions (-H):	-8 dBm
Input Optical Sensitivity:	
WDM (-w versions):	-21 dBm
Standard:	-23 dBm
High sensitivity versions (-H):	-32 dBm
Fiber Size and Type:	
Single Fiber versions:	9 μ m core / single mode
Dual Fiber (F2) versions:	9 μ m core / single-mode on TX, 62.5 μ m core / multi-mode on RX
Long Reach Dual Fiber (F2-L):	9 μ m core / single-mode on TX, 62.5 μ m core / multi-mode on RX
Output Wavelengths:	
Standard:	1310nm, 1550nm (nominal)
CWDM:	1270nm to 1610nm
DWDM:	ITU-T G.694.1 compliant
Output Power:	
Single fiber version:	
1310nm FP (Standard):	-9 dBm \pm 1dBm
-W Version	-1 dBm \pm 1dBm
Dual fiber version:	
1310nm FP (Standard):	-7 dBm \pm 1dBm
CWDM DFB:	0 dBm \pm 1dBm
DWDM:	+7dBm \pm 1dBm

3.3. ELECTRICAL

Voltage:	+ 12VDC
Power:	8 Watts
EMI/RFI:	Complies with FCC regulations for class A devices Complies with EU EMC directive

3.4. PHYSICAL

7800 or 7701 frame mounting:

Number of slots: 1

4. STATUS INDICATORS AND DISPLAYS

The 7708GT has 10 LED Status indicators and a 4 digit alphanumeric display on the front card edge to show operational status of the card at a glance. There are also LED indicators on the two RJ-45 connectors. Figure 5-1 shows the location of the corresponding card edge LEDs.

4.1. STATUS INDICATOR LEDES

4.1.1. Module Health LEDs

Two large LEDs on the front of the board indicate the general health of the module.

LOCAL FAULT: This Red LED indicates poor module health and will be On when there is insufficient optical input power, an optical transmitter failure or if a local input power fault exists (i.e.: a blown fuse). When the FRAME STATUS jumper is set to the ON position the LOCAL FAULT indication will also be reported to the FRAME STATUS bus.

MODULE OK: This Green LED indicates good module health. It will be On when a valid optical input signal is present, and the laser and board power are good.

4.1.2. Fiber Link LED

The LED on the back of the board closest to the top card edge indicates the status of the Fiber link.

FIBER LINK: On the 7708GT, this Green LED indicates the presence of a valid optical link between a pair of 7708GT modules.



In order to establish a valid link between a pair of single fiber 7708GT modules, one module must be configured as 'Address A', and the other as 'Address B'. Selection of the correct address is achieved by setting jumper J6. See section 5.3.

On the 7708GT-F2, this Green LED indicates that the 7708GT-F2 has established a valid link with another 7708GT-F2, and whether the 7708GT-F2 is sending or receiving data on the fiber link. The LED will be ON when the 7708GT-F2 has established a good link, providing a good indication that the fiber segment is connected correctly. The LED will BLINK when the 7708GT-F2 is sending or receiving data. The LED will be OFF if there is no valid connection.

4.1.3. Card Edge Ethernet LEDs

The 6 LEDs on the front edge of the module closest to the center of the module indicate the status of the Ethernet ports. See Figure 5-1 for locations of the card edge LED's.

LINK ACTIVITY: This green LED indicates that the 7708GT is sending or receiving data on the respective Ethernet port. The LED will BLINK when the 7708GT is sending or receiving data. The LED will be OFF if there is no valid connection.

SPEED 1G: The green LED indicates that the 7708GT has established a 1000BaseT fiber link. The LED will be off if 10/100 BaseT link is established on its respective Ethernet port.

DUPLEX: The green LED indicates that the respective Ethernet port is operating under full-duplex mode. The LED will be off if the respective port is working under half-duplex mode.

4.1.4. Rear Panel Ethernet LEDs

There are two LEDs adjacent to the appropriate Ethernet RJ-45 connector on the rear panel that allows you to monitor the Ethernet connection while you connect the cables. See section 2.1 for more information on the Ethernet LEDs.

4.2. DOT-MATRIX DISPLAY

Level 1	Level 2	Level 3	Level 4
LOW, POWER, OVR	BACK		
	CTRL	BACK	
		JFRM	ON (default) ----- OFF
		DISP	HORZ ----- VERT (default)
	STAT	BACK	
		PWR	-7 to -21dBm
		VER	Firmware version

Table 4-1: Dot Matrix Display Menu Selection Items

4.2.1. STATUS MENU SELECTIONS

4.2.1.1. Displaying Optical Power

The 7708GT detects the input optical power and displays this on the four-digit card edge display by default. The following list describes possible displays and their meaning.

STAT	Optical Power Level Display	
PWR		
LOW		LOW: No link established or very low optical power level.
PWR		PWR: Indicates optical input power is within acceptable range (> -21 dB for versions, > -24 dB for -F2 versions and -29 dB for -F2-H versions).
OVR	OVR: On F2-H version indicates that the input power is greater than the maximum allowable level (-7dB).	

4.2.1.2. Displaying the Firmware Version

The **VER** display shows the firmware version and build number of the 7708GT firmware.

STAT	The following is an example of the firmware version build number: For example: VER 1.00 BLD 67
VER	
VER xx	
BLD xxx	

4.2.2. CONTROL MENU SELECTIONS

4.2.2.1. Jumbo Frame Control

Certain network devices being used with the 7708GT will require jumbo frame support. To enable or disable jumbo frames please perform the following menu selections. Jumbo frame support is enabled by default.

CTRL	Jumbo Frame Control
JFRM	
ON	
OFF	OFF: Disable the passing of jumbo frames.

4.2.2.2. Setting the Orientation of the Text on the Card Edge Display

On the 7708GT the **DISP** display enables the user to set a horizontal or vertical orientation for the card edge display messages. After one second the display will show a message indicating the current orientation of the display. When this message is present, press the pushbutton to change the orientation of the display.

CTRL	Jumbo Frame Control
DISP	
HORZ	HORZ: Horizontal display is used when the module is housed in the 1 rack unit 7701FR frame or the stand-alone enclosure.
VERT	VERT: Vertical display is used when the module is housed in the 3-rack unit 7800FR frame.

5. JUMPERS AND USER ADJUSTMENTS

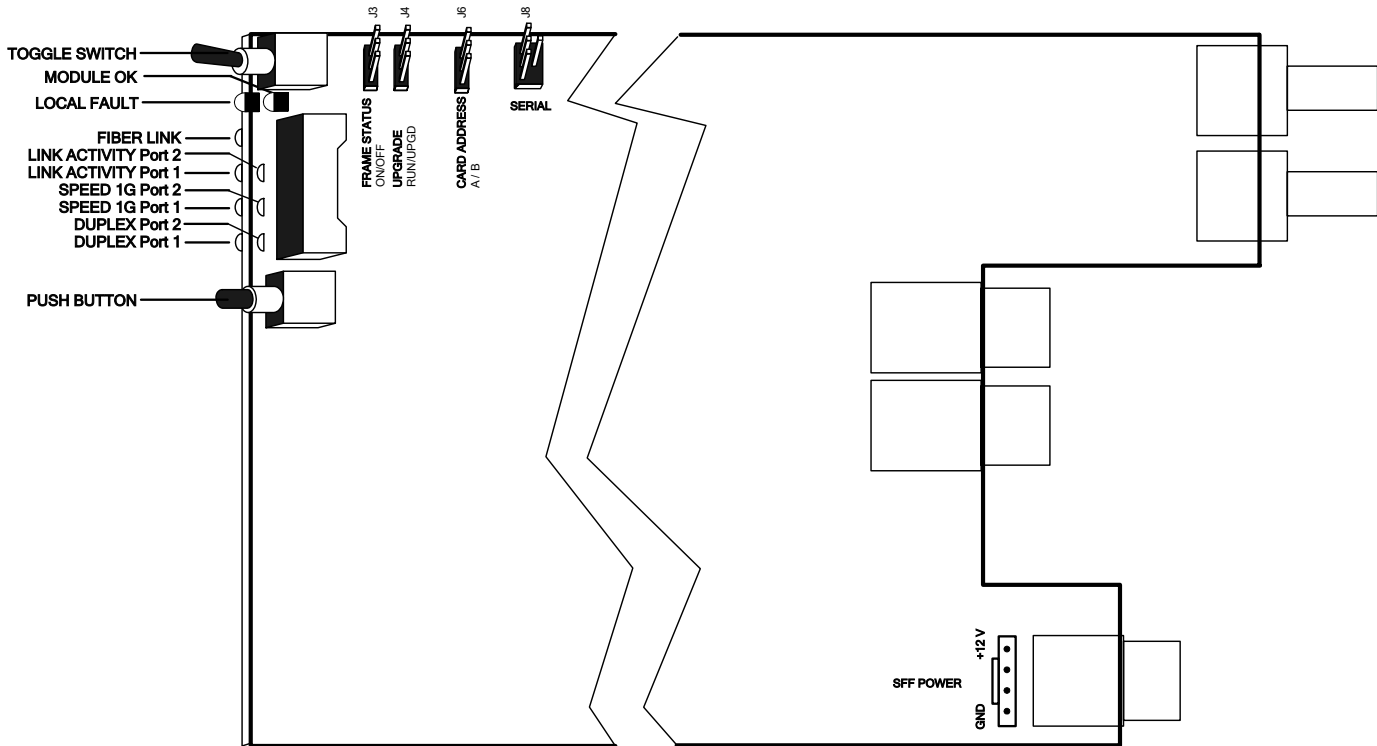

Note: Standard version has one fiber connector; -F2 version has two fiber connectors.

Figure 5-1: LED and Jumper Locations

5.1. SELECTING WHETHER LOCAL FAULTS WILL BE MONITORED BY THE GLOBAL FRAME STATUS

The FRAME STATUS jumper J1 located at the front of the module determines whether local faults (as shown by the Local Fault indicator) will be connected to the 7700FR frame's global status bus.

FRAME STATUS: To monitor faults on this module with the frame status indicators (on the Power Supply FRAME STATUS LED's and on the Frame's Fault Tally output) install this jumper in the On position. (default)

When this jumper is installed in the Off position local faults on this module will not be monitored.

5.2. CONFIGURING THE MODULE FOR FIRMWARE UPGRADES

UPGRADE: The UPGRADE jumper J4 is used when firmware upgrades are being done to the module. For normal operation it should be installed in the *RUN* position. See the *Upgrading Firmware* section of this manual for more information.

To upgrade the firmware in the module unit pull it out of the frame. Move Jumper J4 into the *UPGRADE* position. Install the Upgrade cable provided (located in the vinyl pouch in the front of this manual) onto SERIAL header J8 at the top edge of the card. Re-install the module into the frame. Run the upgrade as described in the *Upgrading Firmware* section of this manual. Once the upgrade is complete, remove the module from the frame, move J4 into the *RUN* position, remove the upgrade cable and re-install the module. The module is now ready for normal operation.

5.3. SELECTING THE CARD ADDRESS (SINGLE FIBER VERSION ONLY)

The Card Address jumper allows each 7708GT module to distinguish its own signal, and that of a sister card at the other end of a fiber link. In the case of an incomplete or damaged fiber link, each 7708GT module will see reflections or its own signal. In order to establish a valid link between a pair of 7708GT modules, one module must be configured as 'Address A', and the other as 'Address B'. Selection of the correct mode is achieved by setting jumper J6, at the front of the board. It does not matter which card is selected as Address A and which as Address B, as long as they are different.

6. VISTALINK® REMOTE MONITORING/CONTROL

6.1. WHAT IS VISTALINK®?

VistaLINK® is Evertz's remote monitoring and configuration platform which operates over an Ethernet network using Simple Network Management Protocol (SNMP). SNMP is a standard computer network protocol that enables different devices sharing the same network to communicate with each other. VistaLINK® provides centralized alarm management, which monitors, reports, and logs all incoming alarm events and dispatches alerts to all the VLPro Clients connected to the server. Card configuration through VistaLINK® PRO can be performed on an individual or multi-card basis using simple copy and paste routines, which reduces the time to configure each module separately. Finally, VistaLINK® enables the user to configure devices in the network from a central station and receive feedback that the configuration has been carried out.

There are 3 components of SNMP:

1. An SNMP manager, also known as a Network Management System (NMS), is a computer running special software that communicates with the devices in the network. Evertz VL-Fiber demo Manager graphical user interface (GUI), third party or custom manager software may be used to monitor and control Evertz VistaLINK® enabled fiber optic products.
2. Managed devices (such as 7708GT), each with a unique address (OID), communicate with the NMS through an SNMP Agent. Evertz VistaLINK® enabled 7700 series modules reside in the 3RU 7700FR-C MultiFrame and communicate with the manager via the 7700FC VistaLINK® frame controller module, which serves as the Agent.
3. A virtual database, known as the Management information Base (MIB), lists all the variables being monitored, which both the Manager and Agent understand. Please contact Evertz for further information about obtaining a copy of the MIB for interfacing to a third party Manager/NMS.

For more information on connecting and configuring the VistaLINK® network, see the 7700FC Frame Controller chapter.

6.2. VISTALINK® CONTROLLED PARAMETERS

The following parameter can be controlled through the VistaLINK® interface.

Parameter	Description
Jumbo Frames	Enable/Disable of Jumbo Frames

Table 6-1: VistaLINK® Controlled Parameters

6.3. VISTALINK[®] MONITORED PARAMETERS

The following parameters can be remotely monitored through the VistaLINK[®] interface.

Parameter	Description
Link OK	Indicates presence of a valid optical link with another 7708GT module. (the state of the FIBER LINK LED)
Optical Power	A range of values describing received optical power at the fiber input.
Ethernet Link	Indicates the presence of a valid link on the Ethernet 1 port. (the state of the LINK LED)
Ethernet Speed	Indicates the detected speed of the link on the Ethernet 1 port.
Ethernet Mode	Indicates whether the Ethernet port is operating in the half duplex or full duplex mode. (the state of the DUPLEX LED)
Card Address	Indicates the state of the CARD ADDRESS jumper. On –F2 versions it always returns a value of zero.

Table 6-2: VistaLINK[®] Monitored Parameters



Please note VistaLINK[®] is currently unsupported in this release. A future release of the 7708GT will support VistaLINK[®]

This page left intentionally blank