

7700 MultiFrame Manual

7700ACO-HD HD/SD-SDI 8-Channel AES & RS-232/RS-422 Auto Changeover User Manual



© Copyright 2020

EVERTZ MICROSYSTEMS LTD.

5292 John Lucas Drive
Burlington, Ontario
Canada L7L 5Z9

Phone:	+1 905-335-3700	Fax:	+1 905-335-3573
Sales:	sales@evertz.com	Fax:	+1 905-335-7571
Tech Support:	service@evertz.com	Twitter:	@EvertzTV
Web Page:	http://www.evertz.com		



Version 1.3, July 2020

The material contained in this manual consists of information that is the property of Evertz Microsystems and is intended solely for the use of purchasers of the 7700Multiframe. Evertz Microsystems expressly prohibits the use of this manual for any purpose other than the operation of the 7700ACO-HD.

All rights reserved. No part of this publication may be reproduced without the express written permission of Evertz Microsystems Ltd. Copies of this manual can be ordered from your Evertz dealer or from Evertz Microsystems.

This page left intentionally blank

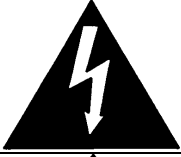
IMPORTANT SAFETY INSTRUCTIONS

	<p>The lightning flash with arrowhead symbol within an equilateral triangle is intended to alert the user to the presence of uninsulated “Dangerous voltage” within the product’s enclosure that may be of sufficient magnitude to constitute a risk of electric shock to persons.</p>
	<p>The exclamation point within an equilateral triangle is intended to alert the user to the presence of important operating and maintenance (Servicing) instructions in the literature accompanying the product.</p>

- Read this information
- Keep these instructions.
- Heed all warnings.
- Follow all instructions.
- Do not use this apparatus near water
- Clean only with dry cloth.
- Do not block any ventilation openings. Install in accordance with the manufacturer’s instructions
- Do not install near any heat sources such as radiators, heat registers, stoves, or other apparatus (including amplifiers) that produce heat.
- Do not defeat the safety purpose of the polarized or grounding type plug. A polarized plug has two blades with one wider than other. A grounding type plug has two blades and a third grounding prong. The wide blade or the third prong is provided for your safety. If the provided plug does not fit into your outlet, consult an electrician for replacement of the obsolete outlet.
- Protect the power cord from being walked on or pinched particularly at plugs, convenience receptacles and the point where they exit from the apparatus.
- Only use attachments/accessories specified by the manufacturer
- Unplug this apparatus during lightning storms or when unused for long periods of time.
- Refer all servicing to qualified service personnel. Servicing is required when the apparatus has been damaged in any way, such as power-supply cord or plug is damaged, liquid has been spilled or objects have fallen into the apparatus, the apparatus has been exposed to rain or moisture, does not operate normally, or has been dropped.

WARNING

TO REDUCE THE RISK OF FIRE OR ELECTRIC – SHOCK, DO NOT EXPOSE THIS APPARATUS TO RAIN OR MOISTURE

WARNING

DO NOT EXPOSE THIS EQUIPMENT TO DRIPPING OR SPLASHING AND ENSURE THAT NO OBJECTS FILLED WITH LIQUIDS ARE PLACED ON THE EQUIPMENT

WARNING

TO COMPLETELY DISCONNECT THIS EQUIPMENT FROM THE AC MAINS, DISCONNECT THE POWER SUPPLY CORD PLUG FROM THE AC RECEPTACLE

WARNING

THE MAINS PLUG OF THE POWER SUPPLY CORD SHALL REMAIN READILY OPERABLE

WARNING



Never look directly into an optical fiber. Non-reversible damage to the eye can occur in a matter of milliseconds.



Do not hook up the 7707MB DWDM cards directly with a short fiber optic cable. The 7707MB DWDM cards produce +7dBm of power which will damage the receiver if connected directly.

INFORMATION TO USERS IN EUROPE

NOTE

This equipment with the CE marking complies with both the EMC Directive (89/336/EEC) and the Low Voltage Directive (73/23/EEC) issued by the Commission of the European Community.

Compliance with these directives implies conformity to the following European standards:

- EN60065 Product Safety
- EN55103-1 Electromagnetic Interference Class A (Emission)
- EN55103-2 Electromagnetic Susceptibility (Immunity)

This equipment has been tested and found to comply with the limits for a Class A digital device, pursuant to the European Union EMC directive. These limits are designed to provide reasonable protection against harmful interference when the equipment is operated in a commercial environment. This equipment generates, uses, and can radiate radio frequency energy and, if not installed and used in accordance with the instruction manual, may cause harmful interference to radio communications. Operation of this equipment in a residential area is likely to cause harmful interference in which case the user will be required to correct the interference at his own expense.

INFORMATION TO USERS IN THE U.S.A.

NOTE

FCC CLASS A DIGITAL DEVICE OR PERIPHERAL

This equipment has been tested and found to comply with the limits for a Class A digital device, pursuant to Part 15 of the FCC Rules. These limits are designed to provide reasonable protection against harmful interference when the equipment is operated in a commercial environment. This equipment generates, uses, and can radiate radio frequency energy and, if not installed and used in accordance with the instruction manual, may cause harmful interference to radio communications. Operation of this equipment in a residential area is likely to cause harmful interference in which case the user will be required to correct the interference at his own expense.

WARNING

Changes or modifications not expressly approved by Evertz Microsystems Ltd. could void the user's authority to operate the equipment.

Use of unshielded plugs or cables may cause radiation interference. Properly shielded interface cables with the shield connected to the chassis ground of the device must be used.

This page left intentionally blank

REVISION HISTORY

<u>REVISION</u>	<u>DESCRIPTION</u>	<u>DATE</u>
1.0	Preliminary Version	Jan 2006
0.2	Added VistaLINK® parameters	Jan 2006
0.3	Added Pool Example to section 6.9	Feb 2006
0.4	Update AES card edge status display	Mar 2006
0.5	Updated GPI/GPO figure in section 2.4	Mar 2006
1.0	Modified features list	Oct 2007
1.1	General format clean up	June 2009
1.2	Removed references to AnSD & AnHD	March 2010
1.3	Updated AES warnings	July 2020

Information contained in this manual is believed to be accurate and reliable. However, Evertz assumes no responsibility for the use thereof nor for the rights of third parties, which may be affected in any way by the use thereof. Any representations in this document concerning performance of Evertz products are for informational use only and are not warranties of future performance, either expressed or implied. The only warranty offered by Evertz in relation to this product is the Evertz standard limited warranty, stated in the sales contract or order confirmation form.

Although every attempt has been made to accurately describe the features, installation and operation of this product in this manual, no warranty is granted nor liability assumed in relation to any errors or omissions unless specifically undertaken in the Evertz sales contract or order confirmation. Information contained in this manual is periodically updated and changes will be incorporated into subsequent editions. If you encounter an error, please notify Evertz Customer Service department. Evertz reserves the right, without notice or liability, to make changes in equipment design or specifications.
limited warranty, stated in the sales contract or order confirmation form.

Although every attempt has been made to accurately describe the features, installation and operation of this product in this manual, no warranty is granted nor liability assumed in relation to any errors or omissions unless specifically undertaken in the Evertz sales contract or order confirmation. Information contained in this manual is periodically updated and changes will be incorporated into subsequent editions. If you encounter an error, please notify Evertz Customer Service department. Evertz reserves the right, without notice or liability, to make changes in equipment design or specifications.

This page left intentionally blank

TABLE OF CONTENTS

1.	OVERVIEW	1
2.	INSTALLATION	3
2.1.	VIDEO CONNECTIONS	3
2.2.	AES IN AND OUT CONNECTIONS	4
2.3.	CONTROL CONNECTIONS	5
2.4.	GENERAL PURPOSE INPUTS AND OUTPUTS	6
3.	SPECIFICATIONS	7
3.1.	SERIAL DIGITAL VIDEO INPUTS	7
3.2.	SERIAL DIGITAL VIDEO OUTPUTS	7
3.3.	AES INPUTS	7
3.4.	AES OUTPUTS	7
3.5.	GENERAL PURPOSE INPUTS AND OUTPUTS	8
3.6.	COMMUNICATIONS AND CONTROL	8
3.7.	ELECTRICAL	8
3.8.	PHYSICAL	8
4.	STATUS INDICATORS	9
4.1.	BANK SELECTION LEDs	9
4.2.	BANK PRESENCE LEDs	10
4.3.	LOCAL / REMOTE STATUS	10
5.	CARD EDGE CONTROLS	11
5.1.1.	Setting Local or Remote Module Control	11
5.1.2.	Setting Control or Monitor Mode	12
6.	CARD EDGE MENU SYSTEM	13
6.1.	NAVIGATING THE MENU SYSTEM	13
6.2.	CARD EDGE STATUS MESSAGES	13
6.2.1.	Display Type of Signal present on HD/SD Input A	14
6.2.2.	Display Which AES are Present on AES Input A	14
6.3.	TOP LEVEL MENU STRUCTURE	15
6.4.	SETTING THE CHANGEOVER MODE	15
6.5.	RESETTING THE MODULE TO FACTORY DEFAULTS	16
6.6.	DISPLAYING THE MODULE FIRMWARE VERSION	16
6.7.	CONFIGURING THE CARD EDGE DISPLAY ORIENTATION	16
6.8.	CONFIGURING MONITORING MODE	16



6.9. SELECTING WHICH INPUT SIGNALS TO SWITCH ON.....	16
6.9.1. Adding an Input Signal to the Pool.....	19
6.10. SETTING THE TYPE OF AUTO CHANGEOVER MODE.....	19
7. JUMPERS	20
7.1. SELECTING WHETHER LOCAL FAULTS WILL BE MONITORED BY THE GLOBAL FRAME STATUS	21
7.2. CONFIGURING THE MODULE FOR FIRMWARE UPGRADES.....	21
8. VISTALINK® REMOTE MONITORING/CONTROL.....	22
8.1. WHAT IS VISTALINK®?	23
8.2. VISTALINK® MONITORED PARAMETERS	24
8.3. VISTALINK® CONTROLLED PARAMETERS	24
8.4. VISTALINK® TRAPS	26
9. MENU QUICK REFERENCE.....	27

Figures

Figure 1-1: 7700ACO-HD Block Diagram.....	2
Figure 2-1: Rear Panel	3
Figure 2-2: Control Connection Pin Out.....	6
Figure 2-3: GPIO Pin Out	6
Figure 4-1: Status LED Locations.....	9
Figure 7-1: Location of Jumpers – Rev 3 Main Board	21
Figure 8-1: VistaLINK® Monitored Parameters	24
Figure 8-2: VistaLINK® Module Fault Traps.....	24
Figure 8-3: VistaLINK® Bank A Fault Traps.....	25
Figure 8-4: VistaLINK® Bank B Fault Traps.....	25
Figure 8-5: VistaLINK® Control	26
Figure 8-6: VistaLINK® Traps	26

Tables

Table 2-1: AES IN A and AES IN B Audio Connector Pin Out	4
Table 2-2: AES OUT Audio Connector Pin Out	4
Table 2-3: AES Audio Breakout Cable (Evertz Part # WPAES8-BNKM-6F).....	5
Table 2-4: GPI Operations.....	6
Table 2-5: GPO Status	6
Table 4-1: Bank Selection LEDs.....	9
Table 4-2: Bank Presence LEDs	10
Table 4-3: Local / Remote LED	10
Table 5-1: DIP Switch Functions – Overview	11
Table 5-2: Local or Remote Control Switch	11
Table 5-3: Control or Monitor Switch	12
Table 6-1: Card Edge Status Messages (Monitor mode is BANK).....	13
Table 6-2: Card Edge Status Messages (Monitor mode is FULL).....	13
Table 6-3: Top Level Menu Structure	15
Table 6-4: Pool Example	17

This page left intentionally blank

1. OVERVIEW

The 7700ACO-HD HD/SD SDI Auto Changeover is designed to provide a HD/SD SDI video, multi-channel AES audio, and RS422/RS232 changeover in a single device. The module can be controlled via GPI, remotely via VistaLINK[®] PRO, or be set in auto changeover mode. It is an all-in-one ACO package aimed towards protecting a complete channel (i.e. video, 8 unbalanced AES, and associated control channel (RS232 or RS422)). The unit also features latching relays that maintain state through a loss of power.

VistaLINK[®] enables control and configuration capabilities via Simple Network Management Protocol (SNMP). This offers the flexibility to manage the module status monitoring and configuration from SNMP enabled control systems such as Evertz VistaLINK[®].

Features:

- Auto detection of signal standard
- Four modes of operation:
 - Auto changeover - two standalone auto changeovers
 - Manual DIP switch control - two independently controlled 2x1 switchers
 - GPI Control - two independently GPI controlled 2x1 switchers
 - Tally output provided
- Protection for 8 channels of AES
- Control channels
- Protection (on HD (1.5Gb/s) or SD (270Mb/s))
- Changeover conditions are based on signal presence of:
 - HD/SDI (TRS timing, CRC and EDH)
 - DVB-ASI (SMPTE sync word); Sync (H timing) and AES (sync word)



Please note: Early versions supported changeover of analog composite and tri-level signals.

- VistaLINK[®] -capable offering remote monitoring, control and configuration capabilities via SNMP
- VistaLINK[®] is available when modules are used with the 3RU 7800FR frame and a 7700FC VistaLINK[®] Frame Controller module in slot 1 of the frame

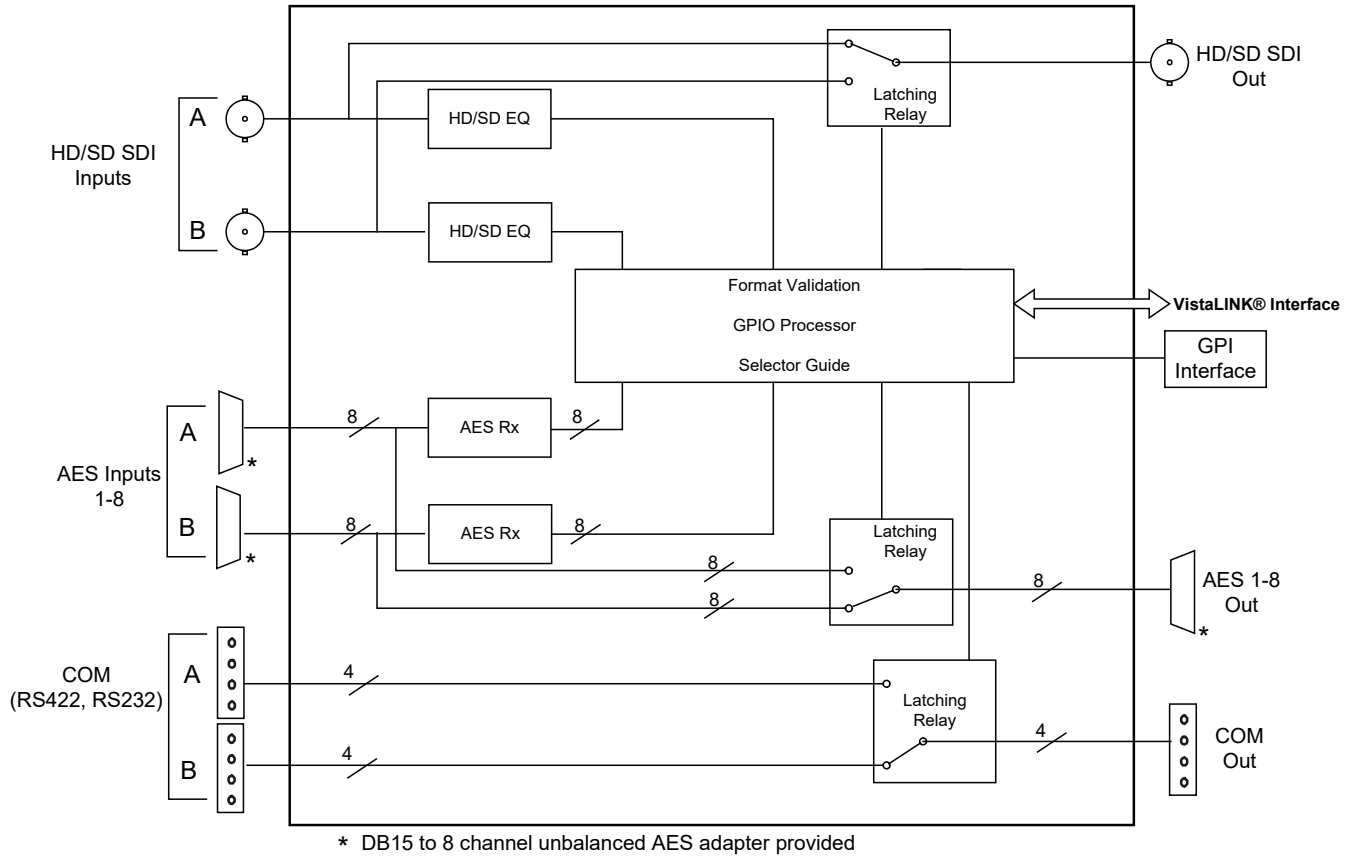

Figure 1-1: 7700ACO-HD Block Diagram

2. INSTALLATION

The 7700ACO-HD comes with a companion rear plate that occupies two slots in the frame. For information on mounting the rear plate and inserting the module into the frame see section 3 of the 7700FR chapter.

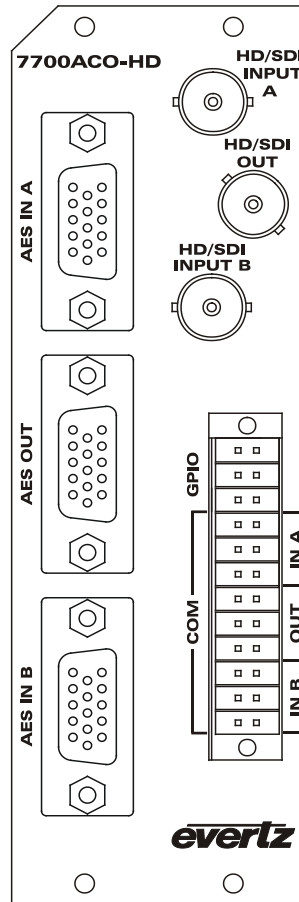

Figure 2-1: Rear Panel

2.1. VIDEO CONNECTIONS

HD/SDI INPUT A and B: The input BNC connector for 10-bit serial digital video signals compatible with the SMPTE 292M, SMPTE 259M, or SMPTE 310M standard.

HD/SDI OUT: This BNC connector is used to output the video as serial component video, compatible with the SMPTE 292M or SMPTE 259M standard (same as input) with embedded audio.



Unused HD/SDI OUT connectors MUST BE terminated with 75 ohms for proper operation. If it is not terminated, in some cases relays MAY oscillate.

2.2. AES IN AND OUT CONNECTIONS

There are two high-density DB-15 connectors labeled **AES IN A** and **AES IN B**. Each connector provides eight unbalanced AES inputs on 8 BNC connectors. There is a third high-density DB-15 connector labeled **AES OUT**. The connector provides eight unbalanced AES outputs on 8 BNC connectors. These inputs and outputs are for unbalanced AES signals conforming to SMPTE 276M. Table 2-1 and Table 2-2 shows the DB-15 connector pin out.

Name	Description	DB-15 Pin
	Reserved for Future Use	1
	Reserved for Future Use	2
	Reserved for Future Use	3
	Reserved for Future Use	4
	Reserved for Future Use	5
	Reserved for Future Use	6
AES In 2	AES Input 2 - Unbalanced	7
	Reserved for Future Use	8
AES In 6	AES Input 6 - Unbalanced	9
AES In 5	AES Input 5 - Unbalanced	10
AES In 1	AES Input 1 - Unbalanced	11
AES In 8	AES Input 8 - Unbalanced	12
AES In 7	AES Input 7 - Unbalanced	13
AES In 4	AES Input 4 - Unbalanced	14
AES In 3	AES Input 3 - Unbalanced	15
GND	Ground	Shell

Table 2-1: AES IN A and AES IN B Audio Connector Pin Out

Name	Description	DB-15 Pin
	Reserved for Future Use	1
	Reserved for Future Use	2
	Reserved for Future Use	3
	Reserved for Future Use	4
	Reserved for Future Use	5
	Reserved for Future Use	6
AES Out 2	AES Output 2 - Unbalanced	7
	Reserved for Future Use	8
AES Out 6	AES Output 6 - Unbalanced	9
AES Out 5	AES Output 5 - Unbalanced	10
AES Out 1	AES Output 1 - Unbalanced	11
AES Out 8	AES Output 8 - Unbalanced	12
AES Out 7	AES Output 7 - Unbalanced	13
AES Out 4	AES Output 4 - Unbalanced	14
AES Out 3	AES Output 3 - Unbalanced	15
GND	Ground	Shell

Table 2-2: AES OUT Audio Connector Pin Out

The 7700ACO-HD is shipped with three breakout cables for the DB-15 connector (Evertz Part # WPAES8-BNCFM-6F), which can be used to facilitate wiring the audio and GPI connections. The pin outs of the cables are shown in Table 2-3.

High Density DB-15 PIN (male)	Wire	Ground/Shield Connection	Labeled Name	Connector Type	7700ACO-HD AES IN A and AES IN B	7700ACO-HD AES OUT
1	Red		W1 RED	WIRE		
2	Green		W2 GREEN	WIRE		
3	Blue		W3 BLUE	WIRE		
4	(not used)		(not used)			
5	(not used)		(not used)			
6	White		W4 WHITE	WIRE		
7	Black	Soldered to DB15 Shell	AES A2	BNC MALE	AES In 2	AES Out 2
8	Yellow		W5 YELLOW	WIRE		
9	Coax	Soldered to DB15 Shell	AES B2	BNC MALE	AES In 6	AES Out 6
10	Coax	Soldered to DB15 Shell	AES B1	BNC MALE	AES In 5	AES Out 5
11	Coax	Soldered to DB15 Shell	AES A1	BNC MALE	AES In 1	AES Out 1
12	Coax	Soldered to DB15 Shell	AES B4	BNC MALE	AES In 8	AES Out 8
13	Coax	Soldered to DB15 Shell	AES B3	BNC MALE	AES In 7	AES Out 7
14	Coax	Soldered to DB15 Shell	AES A4	BNC MALE	AES In 4	AES Out 4
15	Coax	Soldered to DB15 Shell	AES A3	BNC MALE	AES In 3	AES Out 3
Shell	Black		GND	WIRE	GND	GND

Table 2-3: AES Audio Breakout Cable (Evertz Part # WPAES8-BNCFM-6F)



AES OUT connectors MUST BE terminated with 75 ohms for proper operation.

2.3. CONTROL CONNECTIONS

There is a terminal block that allows the user to connect either RS232 or RS422. **COM IN A** and **COM IN B** are used for connecting two RS232/RS422 as inputs. **COM OUT** is used for connecting RS232/RS422 as an output. The input cables can be secured into the removable portion of the terminal strips using a small screwdriver. The removable part of the terminal strip is then inserted into the rear panel and can be secured using the hold down screws. The terminal block pin out for the control connections is shown in Figure 2-2.

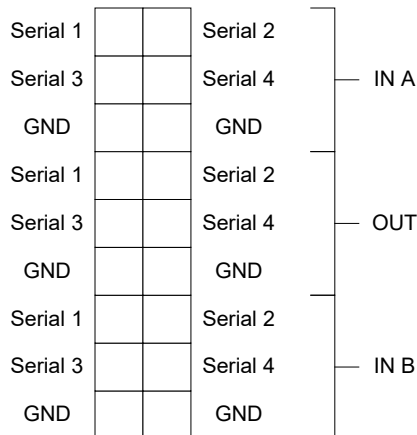

Figure 2-2: Control Connection Pin Out

2.4. GENERAL PURPOSE INPUTS AND OUTPUTS

The 7700ACO-HD has two GPI's and two GPO's available via terminal block. The terminal block pin out is shown in Figure 2-3.

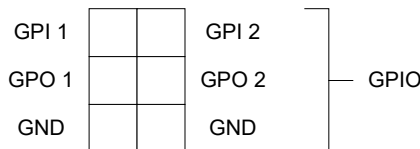

Figure 2-3: GPIO Pin Out

The two GPI's are active if the MODE is set to either GPI or MAN (see section 6.4). Table 2-4 shows the operations that the two GPI's control.

GPI 1	GPI 2	Operation
Low	Low	Current bank selected (no change)
Low	High	Master A inputs selected
High	Low	Master B inputs selected
High	High	Current bank selected (no change)

Table 2-4: GPI Operations

The two GPO's are active in all modes. The GPO's will report different types of status. Table 2-5 describes the status reported by the two GPO's.

	State	Status
GPO 1	Low	Master A is selected
	High	Master B is selected
GPO 2	Low	Master A and B are different
	High	Master A and B have equivalent signals

Table 2-5: GPO Status

3. SPECIFICATIONS

3.1. SERIAL DIGITAL VIDEO INPUTS

Standards:	STMPE 292M (1.5Gb/s), SMPTE 259M-C (270 Mb/s) 525 or 625 line component SMPTE 310M
Number of Inputs:	2
Connector:	2 BNC per IEC 61169-8 Annex A
Maximum Cable Length:	100m of Belden 1694 or equivalent cable combined input and output.
Return Loss:	>10 dB up to 1.5GHz

3.2. SERIAL DIGITAL VIDEO OUTPUTS

Standard:	1.485 Gb/s SMPTE 292M, 270Mb/s SMPTE 259M or SMPTE 310M (same as input)
Number of Outputs:	1 Passive Relay Output
Connector:	BNC per IEC 61169-8 Annex A
Maximum Cable Length:	60m of Belden 1694 or equivalent cable combined input and output
Signal Level:	800mV nominal
DC Offset:	0V \pm 0.5V
Return Loss:	>12 dB up to 1.5GHz

3.3. AES INPUTS

Number of Outputs:	8 Unbalanced AES (per connector)
Connectors:	2 Female High-Density DB-15
Input Level:	1V p-p
Input Impedance:	75 Ω
Return Loss:	>25dB 100kHz to 6MHz
Detection:	Up to 600m with Belden 1694A (or equivalent) @ 48kHz AES signal

3.4. AES OUTPUTS

Number of Outputs:	8 Unbalanced AES (per connector)
Connectors:	1 Female High-Density DB-15
Input Level:	1V p-p
Input Impedance:	Output must be terminated to 75R
Return Loss:	>25dB 100kHz to 6MHz

3.5. GENERAL PURPOSE INPUTS AND OUTPUTS

Type

Inputs:	Opto-isolated input with internal pull-up to +5 Volts
Outputs:	Normally 10k internal pull-up to +5V. Ground to rear panel when relay is in active position
Connectors:	Screw down terminal block
Signal Level:	+5 V nominal

3.6. COMMUNICATIONS AND CONTROL

Serial Port:	RS232/RS422 – 4 wire, terminal block
Connectors:	Terminal block

3.7. ELECTRICAL

Voltage:	+12VDC
Power:	6 Watts
EMI/RFI:	Complies with FCC regulations for class A devices Complies with EU EMC directive

3.8. PHYSICAL

Number of slots:	
350FR:	2
7700FR-C:	2
7800FR:	2

4. STATUS INDICATORS

The 7700ACO-HD has 8 LED Status indicators on the front card edge to show operational status of the card at a glance. Figure 4-1 shows the location of the LEDs and card edge controls.

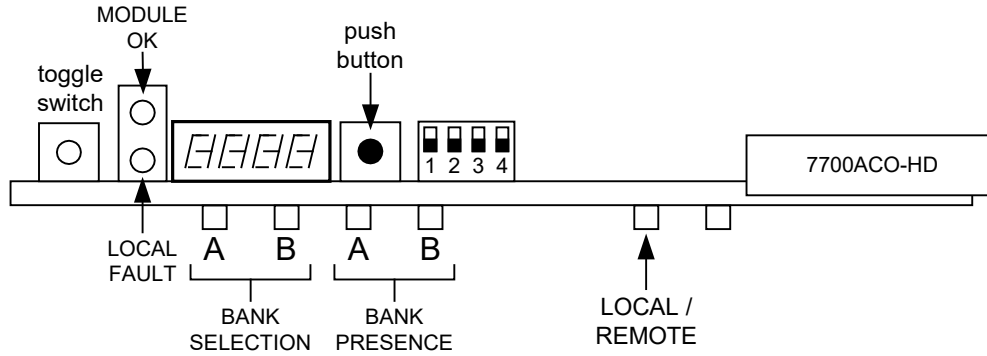

Figure 4-1: Status LED Locations

Two large LEDs on the front of the main board indicate the general health of the module.

LOCAL FAULT: This Red LED indicates poor module health and will be ON during the absence of a valid input signal or if a local input power fault exists (i.e.: a blown fuse). The LOCAL FAULT indication can also be reported to the frame through the FRAME STATUS jumper.



The Red LED will also indicate any differences in signals on Bank A and B (based on POOL settings). The 7700ACO-HD expects to have an equal number of inputs on Banks A and B. If there is a discrepancy, this is considered a fault condition since a switch from the primary (or active) bank to the secondary bank will result in a loss of video or audio (depending on the missing input signal).

MODULE OK: This Green LED indicates good module health. It will be ON when a valid input signal is present, and the board power is good.

4.1. BANK SELECTION LEDES

These two LEDs indicate which input is providing the source for the output. Input A is located at the top leftmost LED.

LED	Colour	Description
A	Off	Bank A is not selected as a source for output.
	Green	Bank A is selected as source for output.
B	Off	Bank B is not selected as source for output.
	Yellow	Bank B is selected as source for output.

Table 4-1: Bank Selection LEDs

4.2. BANK PRESENCE LEDS

These two LEDs indicate which input is present. Input A is located at the top leftmost LED. This status is based on POOL operation (see section 6.9) where any signal in the pool is present.

LED	Colour	Description
A	Off	Bank A is not present.
	Green	Bank A is present.
B	Off	Bank B is not present.
	Green	Bank B is present.

Table 4-2: Bank Presence LEDS

4.3. LOCAL / REMOTE STATUS

This LED indicates whether the 7700ACO-HD is controlled locally (via card edge) or remotely (via VistaLINK®).

LED	Colour	Description
Local/Remote	Off	Remotely controlled via VistaLINK® or card edge.
	Green	Locally controlled via card edge.

Table 4-3: Local / Remote LED

5. CARD EDGE CONTROLS

The 7700ACO-HD can be configured by the card edge controls. There are some key control components that can be found at the card edge:

1. Toggle Switch
2. 4 Character Dot Matrix Display
3. Push Button
4. DIP Switch

Toggle Switch: This component will become active once the card has completed booting. Its primary function is to navigate through the menu system.

4 Character Dot Matrix Display: This component will become active once power is applied to the card. This component is used to relay text-based information to the user. It will be used to scroll build and card information, or display the menu options to the user.

Push Button: This component will become active once the card has completed booting. It is primarily used for navigating through the menu system.

DIP Switch: The 7700ACO-HD is equipped with a 4 position DIP switch to allow the user to set how the module will be controlled and monitored. Table 5-1 gives an overview of the DIP switch functions.

DIP Switch	Function
1	Local (Card Edge) or Remote (VistaLINK®) control
2	Unused
3	
4	Control Mode or Monitor Mode

Table 5-1: DIP Switch Functions – Overview

5.1. SETTING LOCAL OR REMOTE MODULE CONTROL

DIP Switch				Control Description	Value Description
1	2	3	4		
Off				Local or Remote Control	The module is configured by VistaLINK® AND card edge controls
On					The module is configured ONLY by the card edge controls

Table 5-2: Local or Remote Control Switch

5.1.1. Setting Control or Monitor Mode

DIP Switch				Control Description	Value Description
1	2	3	4		
			Off	Control or Monitor Mode	The module is in control mode. The module can be configured by either card edge or VistaLINK® depending on the setting of DIP switch 1.
			On		The module is in monitor mode. The card edge display will report status based on the setting of the MONI parameter (see section 6.8)

Table 5-3: Control or Monitor Switch

6. CARD EDGE MENU SYSTEM

6.1. NAVIGATING THE MENU SYSTEM

You can use the toggle switch to move up and down the list of available parameters. To adjust any parameter, use the toggle switch to move up or down to the desired parameter and press the pushbutton. Using the toggle switch, adjust the parameter to its desired value. If the parameter is a numerical value, the number will increase if you lift the toggle switch and decrease if you push down on the toggle switch. If the parameter contains a list of choices, you can cycle through the list by pressing the toggle switch in either direction. The parameter values are changed as you cycle through the list.

When you have stopped at the desired value, depress the pushbutton. This will return you to the parameter select menu item you are setting (the display shows the parameter name you were setting). To change another parameter, use the toggle switch to select other parameters. If neither the toggle switch nor pushbutton is operated for approximately 30 seconds, the card edge control will exit the menu system and return to an idle state.

6.2. CARD EDGE STATUS MESSAGES

There are four messages that may appear on the card edge display during normal operation (monitor mode) of the module. The messages are:

SW A	Indicates Bank A is active.
SW B	Indicates Bank B is active.

Table 6-1: Card Edge Status Messages (Monitor mode is BANK)

SDIA	Displays the type of signal present at HD/SD Input A.
SDIB	Displays the type of signal present at HD/SD Input B.
AESA	Displays which AES inputs are present at AES Input A.
AESB	Displays which AES inputs are present at AES Input B.

Table 6-2: Card Edge Status Messages (Monitor mode is FULL)

6.2.1. Display Type of Signal present on HD/SD Input A

Both *SDIA* and *SDIB* display the same type of information. For the sake of simplicity in the manual, only *SDIA* is shown below.

<i>SDIA</i>
<i>HD</i>
<i>SD</i>
<i>AES</i>
<i>310M</i>
<i>DASI</i>

This parameter displays the type of input signal detected by the 7700ACO-HD.

HD – The module detects an HD (SMPTE 292M) video signal.

SD – The module detects an SD (SMPTE 259M) video signal.

AES – The module detects an AES signal.

310M – The module detects an MPEG2 Transport video signal.

DASI – The module detects a DVB-ASI signal.

6.2.2. Display Which AES are Present on AES Input A

Both *AESA* and *AESB* display the same type of information. The card edge 4-character matrix display will show the presence of an AES input. The display is read left to right when *DISP* is set to *HORZ* (see section 6.7). If *DISP* is set to *VERT*, then the display is read from top to bottom.

Assuming the *DISP* is set to *HORZ*, the first character represents the presence of AES inputs 1 and 2. The next character represents the presence of AES inputs 3 and 4, and so on. For the sake of simplicity in the manual, only *AESA* is shown below.

<i>AESA</i>
• • •

This parameter displays which AES channels are present on AES Input A.

– This represents no AES inputs present

– This represents AES input 1 is present only

– This represents AES input 2 is present only

– This represents AES inputs 1 and 2 are present

– This represents AES inputs 1 to 3 are present.

– This represents AES inputs 1 to 8 are present.

6.3. TOP LEVEL MENU STRUCTURE

The following is a brief description of the top level of the menu tree (see Table 6-3) that appears when you enter the card edge menu system. Selecting one of these items will take you down into the next menu level to set the value of that parameter. The details of the each of the menu items are described in sections 6.4 to 6.10.

MODE	Changeover Mode	Sets the switch mode.
FRST	Factory Reset	Performs a reset to factory settings.
VER	Firmware Version	Displays the firmware version number.
DISP	Display Orientation	Sets the orientation of the card edge display.
MONI	Monitor Mode	Sets the type of monitoring mode.
POOL	Signals to Monitor	Selects which signals to monitor.
ACOM	Auto Changeover Mode	Sets the type of auto changeover mode.

Table 6-3: Top Level Menu Structure



The menus will timeout (approximately 30 seconds) after a period of inaction. After the timeout period expires, the menu will return to MODE menu.

6.4. SETTING THE CHANGEOVER MODE

MODE
<u>AUTO</u>
GPI
MAN

This parameter is used to set the switch mode of the 7700ACO-HD.

AUTO – This puts the module into auto changeover mode. If a signal in active bank is lost, the module will automatically switch to the second bank.

GPI – The switch between inputs is controlled by general-purpose inputs (GPIs) regardless of input signal presence.

MAN – The switch between inputs is controlled manually by either the card edge push button or remotely via VistaLINK® depending on the DIP switch setting (see section 5.1.1). Also, the card edge pushbutton will trigger a switch between inputs, if DIP switch 4 is set to ON (see section 5.1.2).

6.5. RESETTING THE MODULE TO FACTORY DEFAULTS

FRST
<u>NO</u>
YES

This parameter allows the user to reset the 7700ACO-HD to its factory default condition.

NO – This returns the user to the main menu without affecting the presets.

YES – This returns the module to its factory default condition. Factory defaults are shown underlined in the menu descriptions throughout section 6.

6.6. DISPLAYING THE MODULE FIRMWARE VERSION

VER
<u>"v1.0 BUILD 00"</u>

This parameter allows the user to display the firmware version and build number of the 7700ACO-HD.

6.7. CONFIGURING THE CARD EDGE DISPLAY ORIENTATION

DISP
HORZ
<u>VERT</u>

This parameter allows the user to select a horizontal or vertical orientation for the card edge display to accommodate mounting of the module in the 3RU or 1RU frame.

6.8. CONFIGURING MONITORING MODE

MONI
<u>FULL</u>
BANK

This parameter allows the user to set what information will be displayed on the card edge display when in monitoring mode.

FULL – This displays information related to the bank selected. The information that is displayed is the type of video input and which AES channels are present.

BANK – This displays which bank is currently active.

6.9. SELECTING WHICH INPUT SIGNALS TO SWITCH ON

The 7700ACO-HD uses a pool of input signals to determine when to activate a switch between the two banks. The pool can consist of the input video signal and/or any (or all) of the eight AES inputs. The signals in the pool are monitored in order to activate a switch. The switching behaviour is controlled by the *ACOM* control in section 6.10.

In order to activate a switch to the secondary bank, signals that are present in the primary MUST ALSO be present in secondary bank. A switch will also occur if the secondary bank has the same monitored signals as the primary bank plus some additional monitored signals.

However, if input video is included in the pool, it has the highest priority. Regardless of the state of the AES signals (if included in the pool), if the input video in the primary bank disappears, a switch will occur only if the input video is present in the secondary bank.

Table 6-4 provides examples of this functionality. In the example, the pool contains Input Video, AES 1, AES 3, AES 5, and AES 8. Also in each case, the transition will be from the primary bank to the secondary one.

	Input Video	AES 1	AES 3	AES 5	AES 8	Action
Primary Bank	X	X	X	X	X	In this case, both banks have the same signals present. If any of the signals in the primary bank disappears, a switch to the secondary bank will occur.
Secondary Bank	X	X	X	X	X	
Primary Bank	X	X	X	X	X	The secondary bank is missing AES 1. If AES 3, 5, or 8 disappear in the primary bank, a switch will NOT occur, because the secondary bank does not have AES 1 present. If AES 1 also disappears, then a switch will occur. A switch will occur if the input video signal is lost, regardless of the state of the AES signals.
Secondary Bank	X		X	X	X	
Primary Bank	X	X	X	X		In this case, a switch will occur because the secondary bank has the same signals as the primary plus AES 8.
Secondary Bank	X	X	X	X	X	

Table 6-4: Pool Example

POOL

- VIDE*
- AES1*
- AES2*
- AES3*
- AES4*
- AES5*
- AES6*
- AES7*
- AES8*
- BACK*

This parameter allows the user to select, which signals in the bank are to be monitored. If any of the selected signals is no longer present, the module will switch to the other bank.

There is a strict priority that is followed by the 7700ACO-HD. Video has the highest priority. If the primary (or active) bank loses an AES signal, and the secondary bank is missing a video signal (and is in the pool) the 7700ACO-HD will not switch to the secondary bank. If the video signal is present in the secondary bank, then a switch will occur.

VIDE – Allows the user to include the input video signal to the pool of monitored signals.

AES1 – Allows the user to include the AES 1 input to the pool of monitored signals.

AES2 – Allows the user to include the AES 2 input to the pool of monitored signals.

AES3 – Allows the user to include the AES 3 input to the pool of monitored signals.

AES4 – Allows the user to include the AES 4 input to the pool of monitored signals.

AES5 – Allows the user to include the AES 5 input to the pool of monitored signals.

AES6 – Allows the user to include the AES 6 input to the pool of monitored signals.

AES7 – Allows the user to include the AES 7 input to the pool of monitored signals.

AES8 – Allows the user to include the AES 8 input to the pool of monitored signals.

BACK – Returns the user to the main menu.

6.9.1. Adding an Input Signal to the Pool

In order to include an input signal into the pool of monitored signals, the user must add it. The controls to add *VIDE* and *AES1* to *AES8*, are the same. For the sake of simplicity, only the menu item for *VIDE* is shown.

<i>POOL</i>
<i>VIDE</i>
<i>NO</i>
<i>YES</i>

With this control you add the input video signal to the pool of monitored signals.

NO – The input video will not be included in the pool of monitored signals.

YES – The input video will be included in the pool of monitored signals.

6.10. SETTING THE TYPE OF AUTO CHANGEOVER MODE

<i>ACOM</i>
<i>ACO</i>
<i>ACOA</i>
<i>ACD</i>
<i>ACDA</i>

This parameter allows the user to set the type of changeover that will occur if the *MODE* parameter is set to *AUTO* (see section 6.4).

ACO – The module will be in auto changeover mode where input Bank A and B are treated equally.

ACOA – The module will be in auto changeover mode where input Bank A has priority over Bank B. (i.e. The ACO will switch back to A if A is equal to B based on POOL settings)

ACD – The module will be in auto changeover mode based on DVB-ASI only and where input Bank A and B are treated equally.

ACDA – The module will be in auto changeover mode based on DVB-ASI only and where input Bank A has priority over Bank B.

This page left intentionally blank

7. JUMPERS

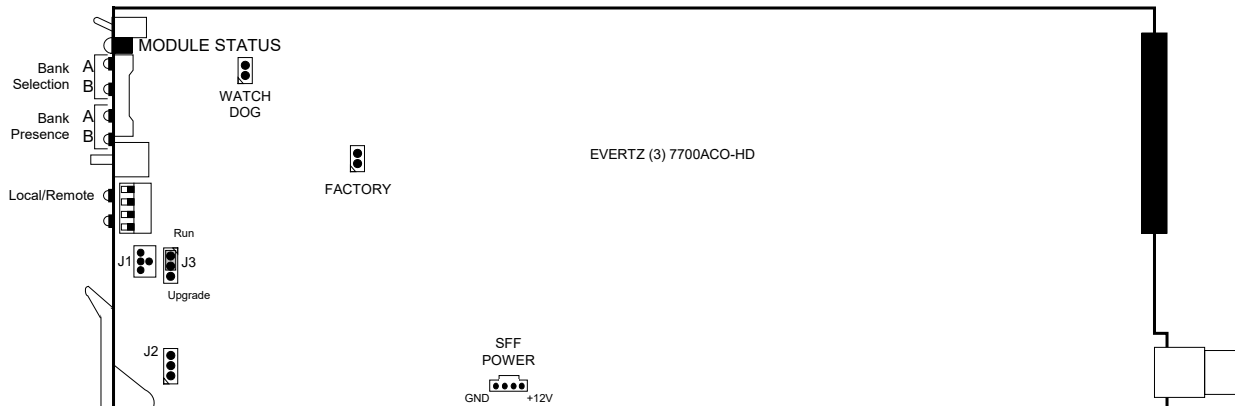

Figure 7-1: Location of Jumpers – Rev 3 Main Board

7.1. SELECTING WHETHER LOCAL FAULTS WILL BE MONITORED BY THE GLOBAL FRAME STATUS

FRAME STATUS: The FRAME STATUS jumper J2 located at the top near the front of the main module determines whether local faults (as shown by the Local Fault indicator) will be connected to the 7700FR frame's global status bus.

To monitor faults on this module with the frame status indicators (on the PS FRAME STATUS LED's and on the Frame's Fault Tally output) install this jumper in the On position. (Default). When this jumper is installed in the Off position, local faults on this module will not be monitored.

7.2. CONFIGURING THE MODULE FOR FIRMWARE UPGRADES

Firmware updates can be performed using the **UPGRADE** jumper.

UPGRADE: The UPGRADE switch is located at J3 jumper on the front side of the main module and is used when firmware upgrades are being done to the module. For normal operation it should be switched to the *RUN* position as shown in the diagrams above. See the *Upgrading Firmware* chapter in the front of the binder for more information.

To upgrade the firmware in the module unit pull it out of the frame. Move Jumper J3 into the *UPGRADE* position. (Install the Upgrade cable provided (located in the vinyl pouch in the front of this manual) onto header J1 at the card edge. Re-install the module into the frame. Run the upgrade as described in the *Upgrading Firmware* chapter. Once the upgrade is completed, remove the module from the frame, move J3 into the *RUN* position, remove the upgrade cable and re-install the module. The module is now ready for normal operation.



The Upgrade baud rate for the 7700ACO-HD module is 115,200 baud.

This page left intentionally blank

8. VISTALINK[®] REMOTE MONITORING/CONTROL

8.1. WHAT IS VISTALINK[®]?

VistaLINK[®] is Evertz's remote monitoring and configuration platform which operates over an Ethernet network using Simple Network Management Protocol (SNMP). SNMP is a standard computer network protocol that enables different devices sharing the same network to communicate with each other. VistaLINK[®] provides centralized alarm management, which monitors, reports, and logs all incoming alarm events and dispatches alerts to all the VLPro Clients connected to the server. Card configuration through VistaLINK[®] PRO can be performed on an individual or multi-card basis using simple copy and paste routines, which reduces the time to configure each module separately. Finally, VistaLINK[®] enables the user to configure devices in the network from a central station and receive feedback that the configuration has been carried out.

There are 3 components of SNMP:

1. An SNMP manager, also known as a Network Management System (NMS), is a computer running special software that communicates with the devices in the network. Evertz VistaLINK[®]Pro Manager graphical user interface (GUI), third party or custom manager software may be used to monitor and control Evertz VistaLINK[®] enabled fiber optic products.
2. Managed devices (such as 7700ACO-HD), each with a unique address (OID), communicate with the NMS through an SNMP Agent. Evertz VistaLINK[®] enabled 7700 series modules reside in the 3RU 7700FR-C MultiFrame and communicate with the manager via the 7700FC VistaLINK[®] frame controller module, which serves as the Agent.
3. A virtual database, known as the Management Information Base (MIB), lists all the variables being monitored, which both the Manager and Agent understand. Please contact Evertz for further information about obtaining a copy of the MIB for interfacing to a third party Manager/NMS.

For more information on connecting and configuring the VistaLINK[®] network, see the 7700FC Frame Controller chapter.

8.2. VISTALINK® MONITORED PARAMETERS

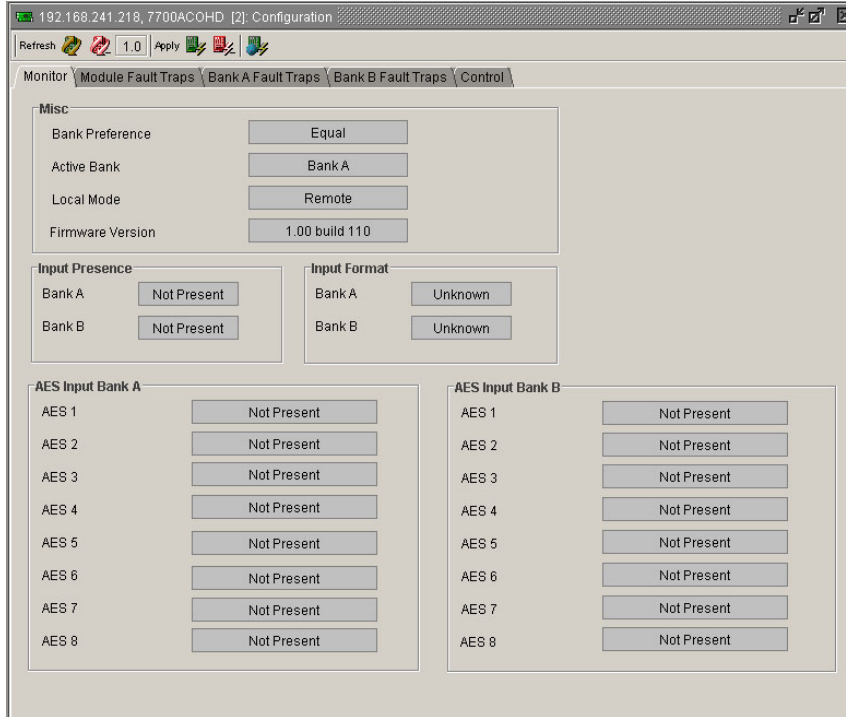

Figure 8-1: VistaLINK® Monitored Parameters

8.3. VISTALINK® CONTROLLED PARAMETERS

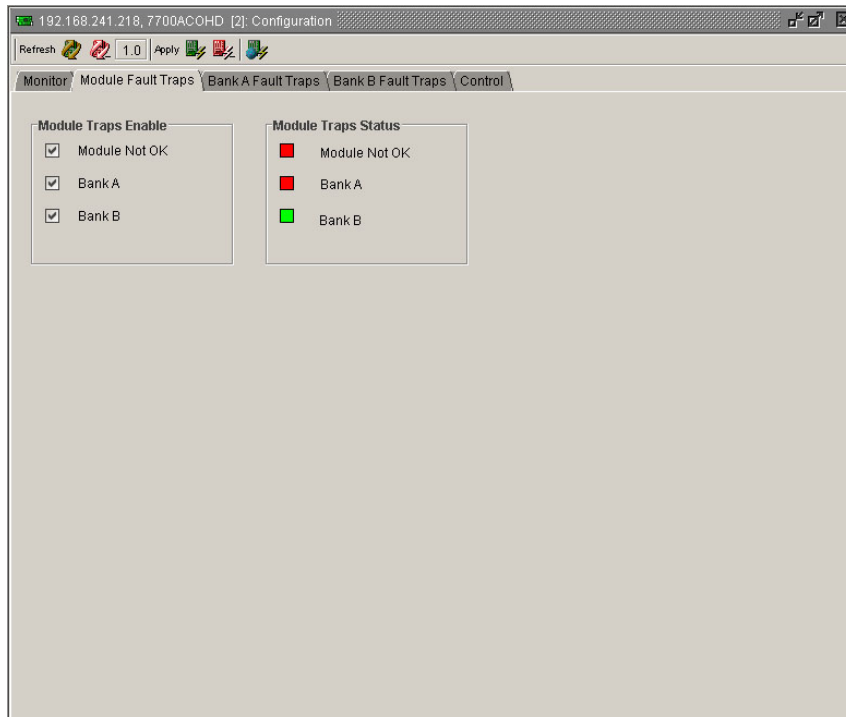

Figure 8-2: VistaLINK® Module Fault Traps

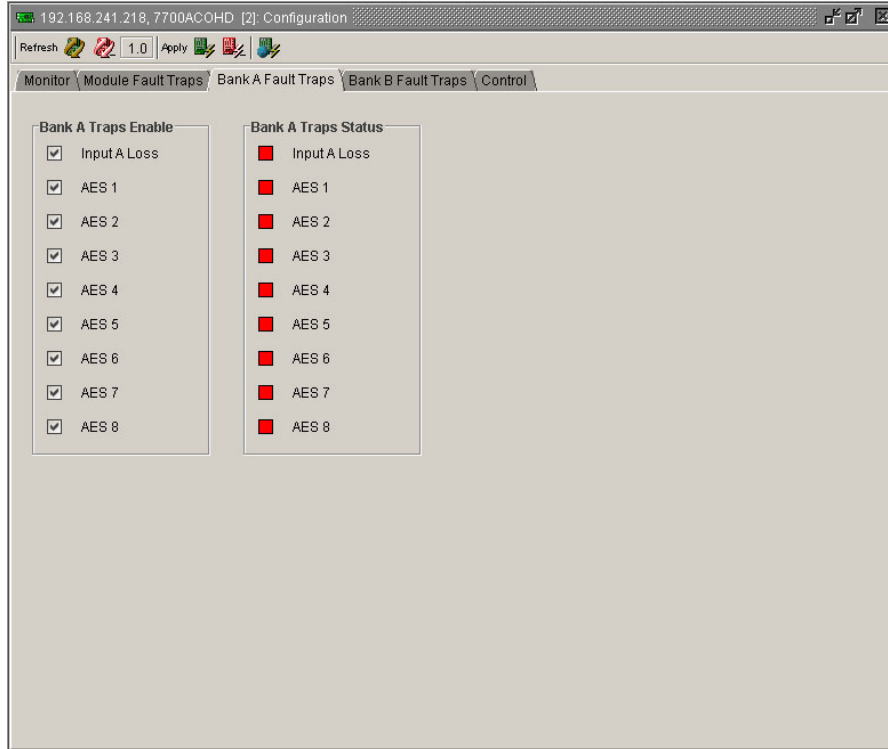

Figure 8-3: VistaLINK® Bank A Fault Traps

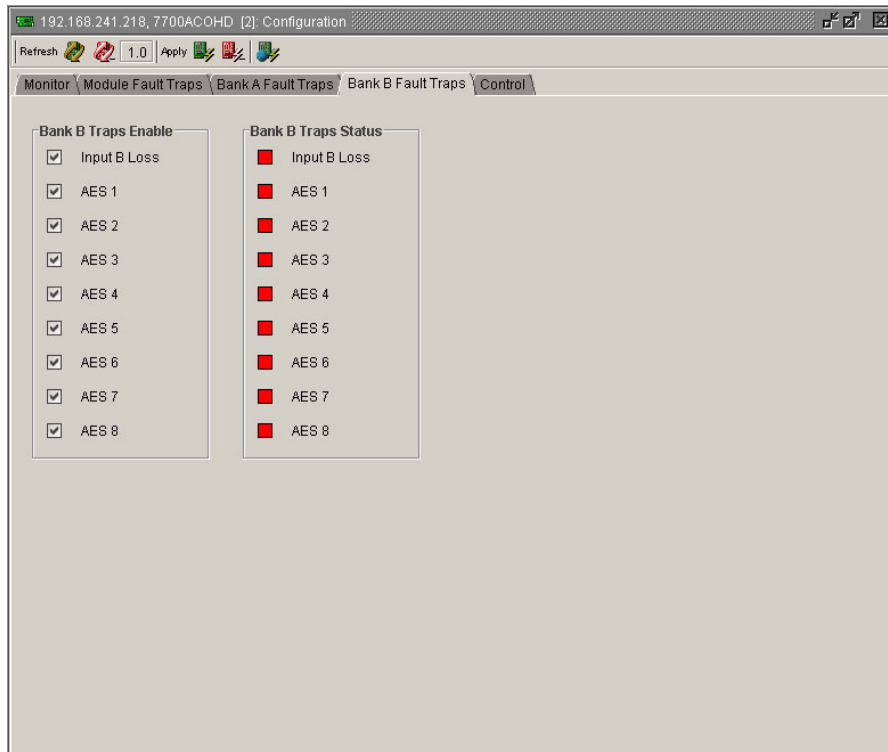

Figure 8-4: VistaLINK® Bank B Fault Traps

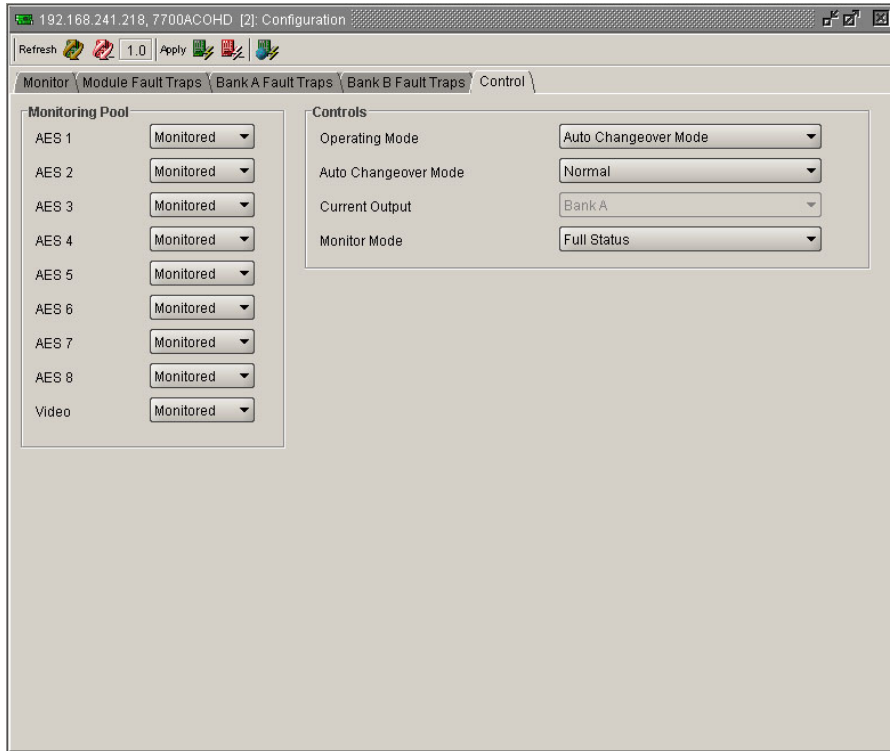

Figure 8-5: VistaLINK® Control

8.4. VISTALINK® TRAPS

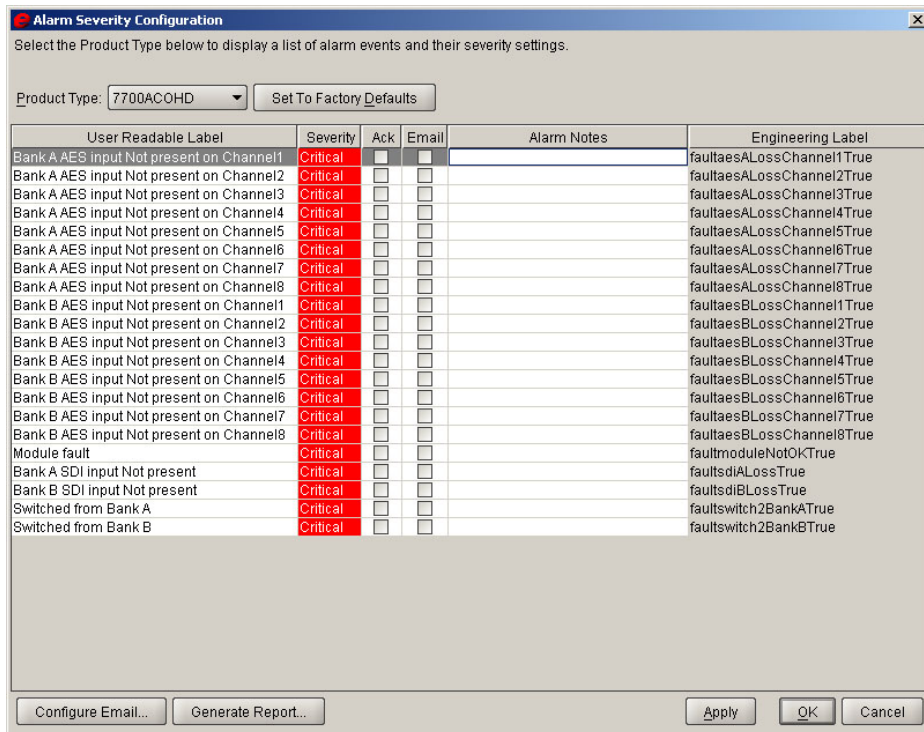

Figure 8-6: VistaLINK® Traps

9. MENU QUICK REFERENCE

Changeover Mode (MODE)

- AUTO
- GPI
- MAN

Factory Reset (FRST)

- YES
- NO

Firmware Version (VER)

Display Orientation (DISP)

- HORZ
- VERT

Monitor Mode (MONI)

- FULL
- BANK

Auto Changeover Mode (ACOM)

- ACO
- ACOA
- ACD
- ACDA

Input Signals to Monitor (POOL)

- VIDE
- AES1
- AES2
- AES3
- AES4
- AES5
- AES6
- AES6
- AES7
- AES8
- BACK

End of Document