

TABLE OF CONTENTS

1.	OVERVIEW.....	1
2.	INSTALLATION.....	3
2.1.	ELECTRICAL SIGNAL CONNECTIONS.....	3
2.2.	OPTICAL CONNECTIONS.....	4
2.3.	CARE AND HANDLING OF OPTICAL FIBER.....	4
3.	SPECIFICATIONS.....	6
3.1.	OPTICAL INPUT.....	6
3.2.	SERIAL VIDEO OUTPUTS.....	6
3.3.	GENERAL PURPOSE OUTPUTS.....	6
3.4.	ELECTRICAL.....	6
3.5.	COMPLIANCE.....	7
3.6.	PHYSICAL.....	7
4.	STATUS INDICATORS AND DISPLAYS.....	8
4.1.	STATUS INDICATOR LEDS.....	8
4.2.	DOT-MATRIX DISPLAY.....	9
4.2.1.	Displaying the Input Video Rate.....	10
4.2.2.	Displaying the Optical Power.....	10
4.2.3.	Displaying the Software Version.....	11
4.2.4.	Selecting Reclocking Rate.....	11
4.2.5.	Selecting GPO Triggers.....	11
4.2.6.	Selecting GPO Polarity.....	12
4.2.7.	Selecting Orientation.....	12
4.2.8.	Selecting Factory Reset.....	12
5.	JUMPERS AND LOCAL CONTROLS.....	13
5.1.	SELECTING WHETHER LOCAL FAULTS WILL BE MONITORED BY THE GLOBAL FRAME STATUS.....	13
5.2.	CONFIGURING THE MODULE FOR FIRMWARE UPGRADES.....	13
6.	VISTALINK® REMOTE MONITORING/CONTROL.....	14

6.1. WHAT IS VISTALINK®?	14
6.2. VISTALINK® MONITORED PARAMETERS	15
6.3. VISTALINK® CONTROLLED PARAMETERS	15
6.4. VISTALINK® TRAPS	15

Figures

Figure 1-1: 7707OE-3G-1 Block Diagram	2
Figure 2-1: 7707OE-3G-1 Rear Panel	3
Figure 2-2: General Purpose Output	4
Figure 4-1: 7707OE-3G-1 Status Indicator and Jumper Locations	8
Figure 4-2: 7707OE-3G-1 Card-edge Menu Quick Reference	9

Tables

Table 6-1: VistaLINK® Monitored Parameters	15
Table 6-2: VistaLINK® Controlled Parameters	15
Table 6-3: VistaLINK® Traps	15

REVISION HISTORY

<u>REVISION</u>	<u>DESCRIPTION</u>	<u>DATE</u>
1.0	First Release	Oct 09

Information contained in this manual is believed to be accurate and reliable. However, Evertz assumes no responsibility for the use thereof nor for the rights of third parties, which may be affected in any way by the use thereof. Any representations in this document concerning performance of Evertz products are for informational use only and are not warranties of future performance, either expressed or implied. The only warranty offered by Evertz in relation to this product is the Evertz standard limited warranty, stated in the sales contract or order confirmation form.

Although every attempt has been made to accurately describe the features, installation and operation of this product in this manual, no warranty is granted nor liability assumed in relation to any errors or omissions unless specifically undertaken in the Evertz sales contract or order confirmation. Information contained in this manual is periodically updated and changes will be incorporated into subsequent editions. If you encounter an error, please notify Evertz Customer Service department. Evertz reserves the right, without notice or liability, to make changes in equipment design or specifications.

WARNING



Never look directly into an optical fiber. Non-reversible damage to the eye can occur in a matter of milliseconds.



Do not hook up the 7707EO-3G-1 DWDM cards and any 7707OE-3G-1 series cards directly with a short fiber optic cable. The 7707EO-3G-1 DWDM card produces +7dBm of power, which will damage the receiver if connected directly.



Do not hook up the 7707EO-3G-1 cards that output more than -7dBm of power (see 7707EO-3G-1 specifications for output power of various laser types) and 7707OE-3G-1-H high sensitivity receiver cards directly with a short fiber optic cable. The 7707EO-3G-1 cards that produce more than -7dBm of power will damage the receiver if connected directly.

1. OVERVIEW

The 7707OE-3G-1 is a *VistaLINK*® enabled, optical to electrical converter for SMPTE 424M (2.970Gb/s), SMPTE 292M (1.485Gb/s), SMPTE 259M-C (270Mb/s), SMPTE 305M (SDTi), and DVB-ASI (270Mb/s). Automatic reclocking, data rate selection and data rate indication is provided for rates from 270Mb/s to 2.970Gb/s. Monitoring and control of card status and parameters is provided locally at the card edge, and remotely via *VistaLINK*®. The 7707OE-3G-1 accepts one fiber input and provides three reclocked coaxial outputs. Also, the 7707OE-3G-1 provides one user selectable GPO.

The 7707OE-3G-1 occupies one card slot and can be housed in either a 1RU frame, which will hold up to three modules, or a 3 RU frame, which will hold up to 15 modules.

Features:

- Supports all SMPTE 424M standards at 2.970Gb/s
- Supports all SMPTE 292M standards at 1.485Gb/s
- Supports all SMPTE 259M-C standards at 270Mb/s
- Supports DVB-ASI (270Mb/s), and SMPTE 305M (SDTi) rates
- Auto rate selection and indication for all SDI, HD-SDI, 3G-SDI data rates from 270Mb/s to 2.970Gb/s
- User enabled GPO configurable to normally open or normally closed
- Reclocked optical input, with selectable non-reclock mode – 3 outputs
- Both outputs maintain polarity from input to output for DVB-ASI applications
- Comprehensive signal and status monitoring via local four-digit card-edge display, or remotely via *VistaLINK*®
- Detection and display of optical input power, and video format
- Display of received optical power for continuous indication of link integrity
- Wide range optical input (1270nm–1610nm)
- Supports multi-mode and single-mode fiber
- Fully hot-swappable from front of frame
- *VistaLINK*® enabled for remote monitoring and control when installed in 7700FR-C frame with 7700FC Frame Controller

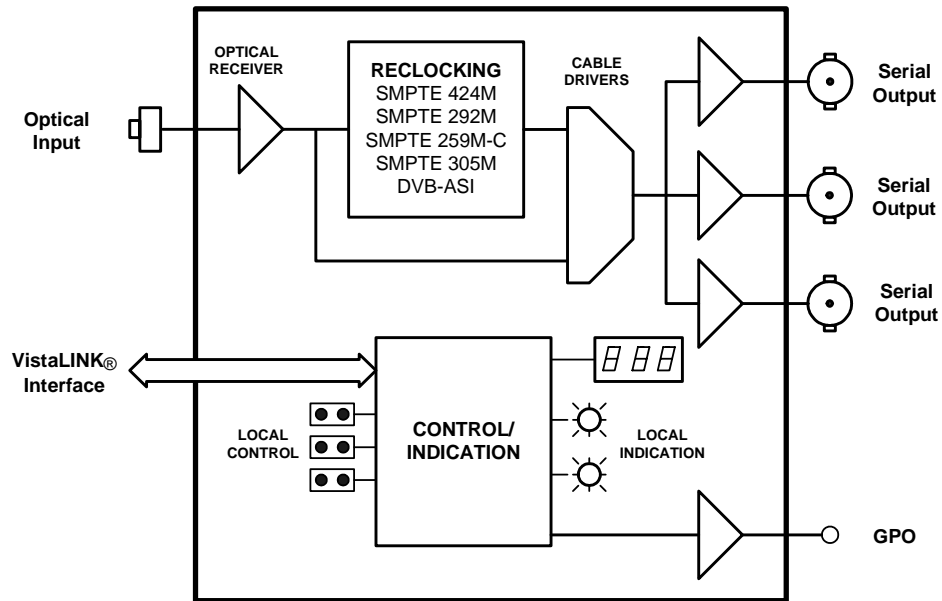

Figure 1-1: 7707OE-3G-1 Block Diagram

2. INSTALLATION

The 7707OE-3G-1 comes with a companion rear plate that has three BNC connectors and one SC/PC (shown), ST/PC or FC/PC optical connector. For information on mounting the rear plate and inserting the module into the frame see section 3 of the 7700FR chapter.

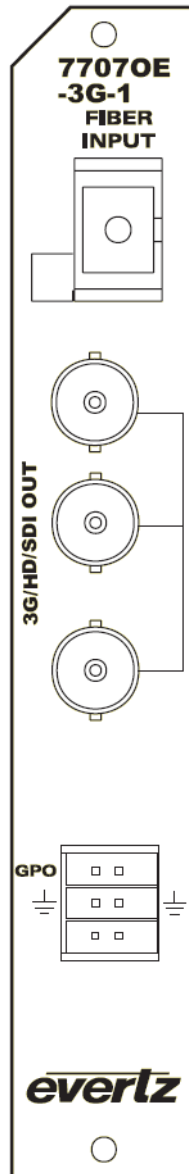

Figure 2-1: 7707OE-3G-1 Rear Panel

2.1. ELECTRICAL SIGNAL CONNECTIONS

3G/HD/SDI OUTPUT: The 7707OE-3G-1 provides three reclocked serial digital video outputs for signal distribution. All outputs maintain the same polarity as the input and is DVB-ASI compliant.

GPO:

The 7707OE-3G-1 provides the user with 1 General Purpose Output. It is dry-contact relay closure. The GPO polarity is user selectable normally open or normally closed, and always open on power loss. Figure 2-2 shows the output circuitry. Refer to section 3.3 for electrical specifications.

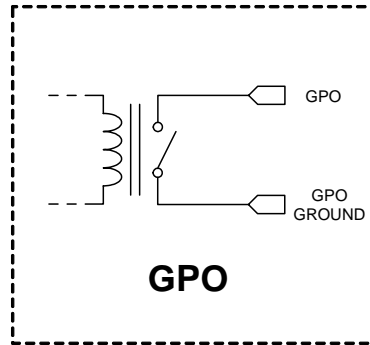

Figure 2-2: General Purpose Output

2.2. OPTICAL CONNECTIONS

OPTICAL INPUT:

Input for SDI optical signals. Available in SC/PC, ST/PC, FC/PC female connectors. Accepts SMPTE 424M, SMPTE 292M, SMPTE 259M, SMPTE 305M, and DVB-ASI optical signals and provides auto-rate selection and reclocking for rates from 270Mb/s to 2.970Gb/s. A non-reclocking mode is also selectable via card edge jumpers, or through the *VistaLINK*® interface. This wide range input accepts optical wavelengths of 1270nm to 1610nm, accommodating standard CWDM or DWDM transmission schemes.



Do not hook up the 7707EO-3G-1 DWDM cards and any 7707OE-3G-1 series cards directly with a short fiber optic cable. The 7707EO-3G-1 DWDM card produces +7dBm of power, which will damage the receiver if connected directly.



Do not hook up the 7707EO-3G-1 cards that output more than -7dBm of power (see 7707EO-3G-1 specifications for output power of various laser types) and 7707OE-3G-1-H high sensitivity receiver cards directly with a short fiber optic cable. The 7707EO-3G-1 cards that produce more than -7dBm of power will damage the receiver if connected directly.

2.3. CARE AND HANDLING OF OPTICAL FIBER



Never touch the end face of an optical fiber. Always keep dust caps on optical fiber connectors when not connected and always remember to properly clean the optical end face of a connector before making a connection.

The transmission characteristics of the fiber are dependent on the shape of the optical core and therefore care must be taken to prevent fiber damage due to heavy objects or abrupt fiber bending. Evertz recommends that you maintain a minimum bending radius of 5 cm to avoid fiber-bending loss that will decrease the maximum attainable distance of the fiber cable. The Evertz fiber optic modules come with cable lockout devices, to prevent the user from damaging the fiber by installing a module into a slot in the frame that does not have a suitable I/O module. For further information about care and handling of fiber optic cable see section 3 of the Fiber Optics System Design chapter in the front of the binder.

3. SPECIFICATIONS

3.1. OPTICAL INPUT

Standards:	SMPTE 297M
Reclocked:	SMPTE 424M, SMPTE 292M, SMPTE 259M C, SMPTE 305M, DVB-ASI, M2S
Non-Reclocked:	Any bi-level signal type at rates of 270Mb/s – 2.970Gb/s
Connector:	Female SC/PC, ST/PC or FC/PC
Wavelength:	1270nm -1610nm
Optical Sensitivity	
Standard:	-21dBm @ 2.970Gb/s
High Sensitivity (-H):	-28dBm @ 2.970Gb/s
Max. Input Power:	
Standard:	-1dBm
High Sensitivity (-H):	-8dBm
Fiber Size:	62 μ m core / 125 μ m overall

3.2. SERIAL VIDEO OUTPUTS

Number of Outputs:	3 Per Card (all outputs DVB-ASI/M2S compliant)
Connectors:	BNC per IEC 61169-8, Annex A
Impedance:	75 Ω (nominal)
Signal Level:	800mV(nominal)
DC Offset:	0V \pm 0.5V
Rise and Fall Time:	< 135ps (HD/3G) < 900ps (SD)
Overshoot:	< 10% of amplitude
Return Loss:	> 15dB to 1.5Ghz > 10dB to 3GHz
Alignment Jitter:	< 0.2UI (Reclocked) to 1.485Gb/s < 0.3UI (Reclocked) to 2.970Gb/s

3.3. GENERAL PURPOSE OUTPUTS

Number of Signals:	1 output
Connector at Breakout:	Multi-pin Removable Terminal Block
Output Type:	Dry contact relay closure to GPO ground, user selectable polarity (Normally Open or Normally Closed), normally open (without power).
Output Current (min):	100mA

3.4. ELECTRICAL

Voltage:	+12VDC
Power:	8 Watts

3.5. COMPLIANCE

Electrical Safety: CSA Listed to CSA C22.2 No. 60065-03, UL 60065-03
IEC 60065-(2001-12) 7th Edition
Complies with CE Low voltage directive 93/68/EEC

EMI/RFI: Complies with FCC regulations for class A devices
Complies with EU EMC directive 89/336/EEC

3.6. PHYSICAL

7700 or 7701 frame mounting:
Number of slots: 1

4. STATUS INDICATORS AND DISPLAYS

The 7707OE-3G-1 has 3 LED Status indicators and a 4 digit alphanumeric display on the front card edge to show operational status of the card at a glance. The card edge pushbutton is used to select various displays on the alphanumeric display. Figure 4-1 shows the location of the card edge status indicators, dot matrix display, pushbutton and jumpers.

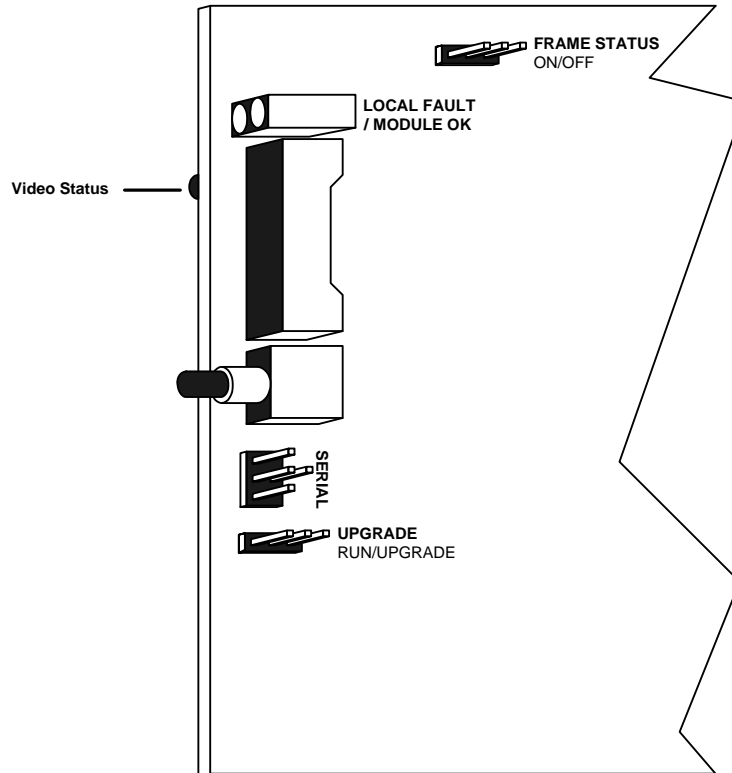

Figure 4-1: 7707OE-3G-1 Status Indicator and Jumper Locations

4.1. STATUS INDICATOR LEDS

LOCAL FAULT: This Red LED indicates poor module health and will be On during the absence of a valid input signal or if a local power fault exists (i.e.: a blown fuse). The LOCAL FAULT indication can also be reported to the frame through the FRAME STATUS jumper.

MODULE OK: This Green LED indicates good module health. It will be On when a valid input signal is present, and the board power is good.

VIDEO STATUS: This LED indicates the status of the optical input video signal. When a valid input video signal is detected the LED will be green. The LED will be yellow if Bypass Mode is selected. If no video is detected on the optical input of the 7707OE-3G-1 the LED will remain off.

4.2. DOT-MATRIX DISPLAY

Additional monitoring and control functions are implemented via the 4-digit dot-matrix display and controls located at the card-edge. The card-edge pushbutton and toggle-switch are used to navigate through the display menu. Figure 4-2 provides a quick reference to the display menu structure.

Pressing the pushbutton advances the display to the next menu level. The toggle-switch may then be used to move up or down through selections of that menu level. Select **BACK** to return to the previous menu level.

If a specific menu selection has a configuration value associated with it, then this may be changed using the toggle switch. Pressing the pushbutton will apply the displayed value and return the user to the previous menu level.



The most recent user selection will be maintained in non-volatile memory in the event of power loss to the module.

Pushbutton →				
	Menu Level 1	Menu Level 2	Menu Level 3	
↑ Toggle Switch ↓	Indications >			
	LOS (Video Loss) Supersedes OK (Okay)			
	Selections >	Selections >	Indications >	
	STAT (Status)	RATE (Signal Rate)	2970 (2970Mbps Rate) 1485 (1495Mbps Rate) 270 (270Mbps Rate) BYP (Reclocker Bypass) LOS (Loss of Signal)	
		PWR (Optical Power)	Indications > 0 to -40 (dBm) OVER (Over Power) LOW (Low Power)	
		VER (Software Version)	Indications > Software Version	
		BACK (Abort)		
	CTRL (Control)	Selections >	Indications >	
		RATE (Signal Rate)	AUTO (Auto Rate / Bypass) 2970 (2970Mbps Rate) 1485 (1495Mbps Rate) 270 (270Mbps Rate) BYP (Reclocker Bypass)	
		GPO (GPO Triggers)	Selections >	Selections >
LOS (Loss of Fiber Signal)			EN (Enable Trigger) DIS (Disable Trigger)	
		POL (GPO Polarity)	Selections > OPEN (Normally Open) CLOS (Normally Closed)	
DISP (Display Orientation)		Selections >	HORZ (Horizontal) VERT (Vertical)	
FRST (Factory Reset)	Selections >	NO (Abort) YES (Accept)		
	BACK (Abort)			

Figure 4-2: 77070E-3G-1 Card-edge Menu Quick Reference

4.2.1. Displaying the Input Video Rate

The card-edge display of the 7707OE-3G-1 can report the video rate present at the optical input. To indicate the input video rate, select the *STAT* (Status) menu item in menu level 1 followed by *RATE* (Input Video Rate).

<i>STAT</i>
<i>RATE</i>
2970
1485
270
<i>BYP</i>
<i>LOS</i>

The following list describes possible indications for this menu selection:

2970	SMPTE 424M: 2.97Gb/s 3G.
1485	SMPTE 305M: 1.485Gb/s HD.
270	SMPTE 259M C: 270Mb/s 525i or 625i, DVB-ASI.
<i>BYP</i>	Indicates reclocker is in non-reclock mode.
<i>LOS</i>	Indicates that no valid input signal is present.

4.2.2. Displaying the Optical Power

The 7707OE-3G-1 is equipped with an on-board optical power meter and can report the power to the card edge display in units of dBm. To indicate the input strength of the received signal, select the *STAT* (Status) menu item in menu level 1 followed by the *PWR* (Optical Power) menu option.

<i>STAT</i>
<i>PWR</i>
-40 to 0
<i>LOW</i>
<i>OVR</i>

The following list describes possible indications for this menu selection:

-40 to 0	Power monitoring range (in dBm units) for the standard optical receiver option.
-40 to -7	Power monitoring range (in dBm units) for the high sensitivity (-H) optical receiver option.
<i>LOW</i>	Received optical power is less than -40dBm.
<i>OVR</i>	Received optical power is greater than maximum.



Never exceed the maximum specified optical input power for the specific product option that you possess. See section 3.1 for optical input specifications. Exceeding the maximum optical input power can permanently damage the optical receiver.

4.2.3. Displaying the Software Version

Software operating on the 7707OE-3G-1 has a version number associated with it. This version number can be indicated to the display. By this means, it can be verified that the module is operating with the most recent software. To indicate the software version to the display, select the *STAT* (Status) menu item in menu level 1, followed by the *VER* (Software Version) menu item.

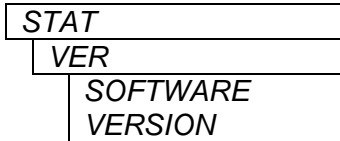

VER x.x BUILD xxx Software version. Character string scrolls across four digit display.

The user can select the *BACK* menu item to return to menu level 1.

4.2.4. Selecting Reclocking Rate

User configuration selects the reclocking rate. If the *AUTO* mode is selected, detected input rate will be reclocked. Otherwise, the reclocking rate will be as selected. To configure the reclocking rate by the 7707OE-3G-1, select the *CTRL* (Control) menu item in menu level 1, followed by the *RATE* (Video Rate) menu items.

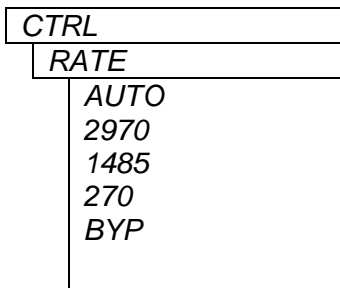

The following list describes possible user selections for this menu item:

- AUTO** Sets the reclocking rate to auto detect.
- 2970** Sets the reclocking rate to 2970Mb/s.
- 1485** Sets the reclocking rate to 1485Mb/s.
- 270** Sets the reclocking rate to 270Mb/s.
- BYP** Sets the reclocking rate to bypass mode.

4.2.5. Selecting GPO Triggers

The 7707OE-3G-1 provides a user-enabled GPO. The GPO has logical function for loss of fiber input signal. To configure the GPO enable mode, select the *CTRL* (Control) menu item in menu level 1 followed by the *GPO* (GPO) and *LOS* (Loss of Fiber Input) menu items.

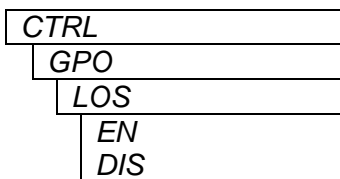

The following list describes possible user selections for this menu item:

- EN** Enables GPO.
- DIS** Disables GPO.

4.2.6. Selecting GPO Polarity

The GPO polarity of the 7707OE-3G-1 is user selectable. When set to *Normally Open*, GPO and GPO Ground are connected only when card fault exists. When set to *Normally Closed*, GPO and GPO Ground are connected until card fault exists, at which point GPO and GPO Ground become disconnected. To configure the GPO Polarity mode, select the CTRL (Control) menu item in menu level 1 followed by the GPO (GPO) and POL (Polarity) menu items.

CTRL
GPO
POL
OPEN
CLOS

The following list describes possible user selections for this menu item:

- OPEN** GPO Polarity Normally Open.
- CLOS** GPO Polarity Normally Close.

Note: Card fault exists when Fiber Input is Lost.

4.2.7. Selecting Orientation

The 7707OE-3G-1 provides the ability to adjust the orientation of the display. When using a 3RU frame it is convenient to have the text read vertical whereas when using a 1RU frame a horizontal display is desirable. To change the orientation of the display select the CTRL (Control) menu item in menu level 1, followed by the DISP (Display) menu option.

CTRL
DISP
HORZ
VERT

- HORZ** Sets the orientation of the text to horizontal.
- VERT** Sets the orientation of the text to vertical.

4.2.8. Selecting Factory Reset

It is convenient to have a quick method of returning all configuration settings to a known value. The 7707OE-3G-1 provides a factory reset for this purpose. All values which are user configurable will be returned to a known state, as indicated below. To initialize a factory reset, select the CTRL (Control) menu item in menu level 1, followed by the FRST (Factory Reset) menu item.

CTRL
FRST
NO
YES

- NO** Return to previous menu item, without modification of configuration settings.
- YES** Initialize factory reset.

The user can select the BACK menu item to return to menu level 1.

5. JUMPERS AND LOCAL CONTROLS

Several jumpers, located at the front of the module, are used to preset various operating modes. Figure 4-1 shows the locations of the jumpers.

5.1. SELECTING WHETHER LOCAL FAULTS WILL BE MONITORED BY THE GLOBAL FRAME STATUS

The FRAME STATUS jumper determines whether local faults (as shown by the Local Fault indicator) will be connected to the 7700FR frame's global status bus.

FRAME STATUS: To monitor faults on this module with the frame status indicators (on the Power Supply FRAME STATUS LED's and on the Frame's Fault Tally output) install this jumper in the On position (default)

When this jumper is installed in the Off position local faults on this module will not be monitored.

5.2. CONFIGURING THE MODULE FOR FIRMWARE UPGRADES

UPGRADE: The UPGRADE jumper is used when firmware upgrades are being done to the module. For normal operation it should be installed in the *RUN* position (see NOTE 1 below). See the *Upgrading Firmware* section of this manual for more information.

To upgrade the firmware in the module unit pull it out of the frame. Move the UPGRADE jumper into the *UPGRADE* position (see NOTE 1). Install the Upgrade cable provided (located in the vinyl pouch in the front of this manual) onto the SERIAL header at the card edge. Re-install the module into the frame. Run the upgrade as described in the *Upgrading Firmware* section of this manual. Once the upgrade is complete, remove the module from the frame, move the UPGRADE jumper into the *RUN* position, remove the upgrade cable and re-install the module. The module is now ready for normal operation.

6. VISTALINK® REMOTE MONITORING/CONTROL

6.1. WHAT IS VISTALINK®?

VistaLINK® is Evertz's remote monitoring and configuration platform which operates over an Ethernet network using Simple Network Management Protocol (SNMP). SNMP is a standard computer network protocol that enables different devices sharing the same network to communicate with each other. VistaLINK® provides centralized alarm management, which monitors, reports, and logs all incoming alarm events and dispatches alerts to all the VLPro Clients connected to the server. Card configuration through VistaLINK® PRO can be performed on an individual or multi-card basis using simple copy and paste routines, which reduces the time to configure each module separately. Finally, VistaLINK® enables the user to configure devices in the network from a central station and receive feedback that the configuration has been carried out.

There are 3 components of SNMP:

1. An SNMP manager, also known as a Network Management System (NMS), is a computer running special software that communicates with the devices in the network. Evertz VL-Fiber demo Manager graphical user interface (GUI), third party or custom manager software may be used to monitor and control Evertz *VistaLINK®* enabled fiber optic products.
2. Managed devices, (such as 7707EO-3G-1 and 7707OE-3G-1 cards), each with a unique address (OID), communicate with the NMS through an SNMP Agent. Evertz *VistaLINK®* enabled 7700 series modules reside in the 3RU 7700FR-C MultiFrame and communicate with the manager via the 7700FC *VistaLINK®* frame controller module, which serves as the Agent.
3. A virtual database, known as the Management information Base (MIB), lists all the variables being monitored, which both the Manager and Agent understand. Please contact Evertz for further information about obtaining a copy of the MIB for interfacing to a third party Manager/NMS.

For more information on connecting and configuring the *VistaLINK®* network, see the 7700FC Frame Controller chapter.

6.2. VISTALINK[®] MONITORED PARAMETERS

The following parameters can be remotely monitored through the *VistaLINK[®]* interface.

Parameter	Description
Signal Standard	A range of values describing the detected video signal rate.
Optical Power	A range of values describing optical power at the fiber input.

Table 6–1: VistaLINK[®] Monitored Parameters

6.3. VISTALINK[®] CONTROLLED PARAMETERS

The following parameters can be remotely controlled via the *VistaLINK[®]* interface.

Parameter	Description
Signal Rate	Sets reclocking rate.
Fiber LOS GPO Trigger	Sets loss of fiber signal GPO mode.
GPO Polarity	Sets GPO polarity.
Optical Power Alarm Threshold	Sets optical power level that triggers an alarm if the fiber signal is lost.

Table 6–2: VistaLINK[®] Controlled Parameters

6.4. VISTALINK[®] TRAPS

The following parameters can be remotely enabled and monitored through the *VistaLINK[®]* interface as traps in the *Alarm View*.

Trap	Description
Signal Loss	Triggers on loss of input video signal.
Optical Power Below Threshold	Triggers on optical power below set threshold.

Table 6–3: VistaLINK[®] Traps

This page left intentionally blank