

---

---

## TABLE OF CONTENTS

1.	OVERVIEW.....	1
2.	INSTALLATION.....	8
2.1.	ETHERNET CONNECTIONS .....	8
2.2.	T1/E1/J1 CONNECTIONS (TE1 VERSIONS ONLY) .....	9
2.3.	OPTICAL CONNECTIONS.....	10
2.3.1.	Single Fiber versions.....	10
2.3.2.	Dual Fiber Versions (-F2 versions).....	11
2.4.	CARE AND HANDLING OF OPTICAL FIBER.....	11
2.4.1.	Safety .....	11
2.4.2.	Assembly.....	11
2.4.3.	Labeling.....	11
2.4.4.	Handling and Connecting Fibers .....	12
3.	SPECIFICATIONS.....	13
3.1.	ETHERNET INPUT/OUTPUT .....	13
3.2.	T1/E1/J1 INPUT/OUTPUT (TE1 VERSIONS ONLY) .....	13
3.3.	OPTICAL INPUT/OUTPUT.....	14
3.4.	ELECTRICAL .....	14
3.5.	PHYSICAL.....	14
4.	STATUS INDICATORS AND DISPLAYS .....	15
4.1.	STATUS INDICATOR LEDES .....	15
4.1.1.	Module Health LEDs .....	15
4.1.2.	Fiber Link LED .....	15
4.1.3.	Card Edge Ethernet LEDs.....	15
4.1.4.	Rear Panel Ethernet LEDs.....	16
4.1.5.	Card Edge T1/E1/J1 LEDs (TE1 Versions Only).....	16
4.1.6.	Rear Panel T1/E1/J1 LEDs (TE1 Versions Only).....	17
4.2.	DOT-MATRIX DISPLAY .....	17
4.2.1.	Displaying optical power .....	17
4.2.2.	Displaying Ethernet Port Status (7707ET-4 and 7707ET-4-F2 only) .....	17
5.	JUMPERS AND USER ADJUSTMENTS.....	18
5.1.	DIP SWITCH SETTINGS (TE1 VERSION ONLY).....	19

5.2. SELECTING WHETHER LOCAL FAULTS WILL BE MONITORED BY THE GLOBAL FRAME STATUS.....	19
5.3. CONFIGURING THE MODULE FOR FIRMWARE UPGRADES .....	20
5.4. SELECTING THE CARD ADDRESS (SINGLE FIBER VERSION ONLY).....	20
6. <i>VISTA</i> LINK® REMOTE MONITORING/CONTROL .....	21
6.1. WHAT IS <i>VISTA</i> LINK®? .....	21
6.2. <i>VISTA</i> LINK® MONITORED PARAMETERS .....	22
6.3. <i>VISTA</i> LINK® CONTROLLED PARAMETERS .....	22

## Figures

Figure 1-1: 7707ET Block Diagram.....	4
Figure 1-2: 7707ET-F2 Block Diagram .....	4
Figure 1-3: 7707ET-TE1 Block Diagram .....	5
Figure 1-4: 7707ET-TE1-F2 Block Diagram .....	5
Figure 1-5: 7707ET-4 Block Diagram .....	6
Figure 1-6: 7707ET-4-F2 Block Diagram .....	7
Figure 2-1: 7707ET Rear Panels .....	8
Figure 2-2: Reproduction of Laser Certification and Identification Label.....	12
Figure 5-1: LED and Jumper Locations (ET versions).....	18
Figure 5-2: LED and Jumper Locations (ET-4 versions) .....	18
Figure 5-3: LED and Jumper Locations (TE1 versions).....	19

## Tables

Table 1-1: 7707ET Typical Application Configurations.....	2
Table 1-2: 7707ET-TE1 Typical Application Configurations .....	3
Table 1-3: 7707ET-4 Typical Application Configurations.....	3
Table 2-1: Ethernet Connector Pin Definitions and Cable Wiring.....	9
Table 2-2: T1/E1/J1 Connector Pin Definitions and Cable Wiring.....	10
Table 6-1: <i>Vista</i> LINK® Monitored Parameters .....	22

---

## REVISION HISTORY

<u>REVISION</u>	<u>DESCRIPTION</u>	<u>DATE</u>
0.1	Preliminary Version	Sept 2001
1.0	First release version Drawings and specs updated	Nov 2001
1.1	Specifications and drawing updated, Vistalink™ section added	Jan 2002
1.1.1	Specifications updated	Mar 2002
1.2	Changed model number of 7707ET-FC to 7707ET Added 7707ET-4 and 7707ET-TE1	Mar 2002
1.2.1	Updated Specifications for Optical I/O, updated info on Address Jumper	Jun 2002
1.3	Added 8 new CWDM wavelengths	Dec 2002
1.4	Added 7707ET-4-F2	May 2003
1.5	Added DIP switch to TE! Version, Updates TE1 version information	Jun 2003
1.6	Added Application Configuration tables	Aug 2003
1.7	Updated safety section and added assembly and labeling sections	Aug 2005
1.8	Added Impedance Specification	Sept 2007
1.9	General format cleanup	Apr 2009
1.10	Updated 7707ET Typical Application Configurations table	July 2011

Information contained in this manual is believed to be accurate and reliable. However, Evertz assumes no responsibility for the use thereof nor for the rights of third parties, which may be affected in any way by the use thereof. Any representations in this document concerning performance of Evertz products are for informational use only and are not warranties of future performance, either expressed or implied. The only warranty offered by Evertz in relation to this product is the Evertz standard limited warranty, stated in the sales contract or order confirmation form.

Although every attempt has been made to accurately describe the features, installation and operation of this product in this manual, no warranty is granted nor liability assumed in relation to any errors or omissions unless specifically undertaken in the Evertz sales contract or order confirmation. Information contained in this manual is periodically updated and changes will be incorporated into subsequent editions. If you encounter an error, please notify Evertz Customer Service department. Evertz reserves the right, without notice or liability, to make changes in equipment design or specifications.



**Never look directly into an optical fiber. Non-reversible damage to the eye can occur in a matter of milliseconds.**



**Do not hook up the 7707ET, 7707ET-TE1 or 7707ET-4 DWDM cards directly with a short fiber optic cable. These DWDM cards produce +7dBm of power, which will damage the receiver if connected directly.**

## 1. OVERVIEW

The 7707ET series Ethernet Fiber Transceivers provide an economical method of transmitting 10BaseT Ethernet channels or one 100Base-TX Ethernet channel over optical fiber. The transceivers are IEEE 802.3 10BASE-T and IEEE 802.3u 100BASE-TX compliant, and mediates between a 10/100BASE-TX segment. A pair of 7707ET transceivers permits full duplex communication over a single optical fiber or dual fiber. Diagnostic LEDs provide indication of power, linkage and data reception.

### Features:

- Auto negotiation for 10/100 speeds, half/full duplex modes
- Built in Ethernet switch for complete isolation of each transmission end
- Link status monitoring indicators
- VistaLINK<sup>®</sup> enabled for remote monitoring and control
- Optical output available in 1310nm, 1550nm and up to sixteen CWDM wavelengths in the 1270nm to 1610nm range
- Supports multi-mode or single-mode fiber
- Fully hot-swappable from front of frame with no fiber or Ethernet channel disconnect required
- SC/PC, ST/PC or FC/PC connector options

Four versions of the 7707ET allow the user to choose the optimal price / performance / features to suit a particular application. The “-F2” versions are designed to receive and transmit, on the same wavelength, over two different fibers and have the lowest insertion loss. These versions can operate with Multi-mode or Single-mode fiber. The other versions are designed to receive and transmit on the same wavelength over a single fiber and can operate with single mode fiber only. The “-TE1” version allows transmission of one Ethernet and one T1 signal over a single fiber.

Model	Optical Configuration	Ethernet	Other Signals
<b>7707ET</b> <b>(Formerly called</b> <b>7707ET-FC)</b>	Single Fiber	2 10BASE-T or 1 100BASE-TX	
<b>7707ET-F2</b>	Dual Fiber	2 10BASE-T or 1 100BASE-TX	
<b>7707ET-4</b>	Single Fiber	4 10BASE-T or 4 100BASE-TX	
<b>7707ET-4-F2</b>	Dual Fiber	4 10BASE-T or 4 100BASE-TX	
<b>7707ET-TE1</b>	Single Fiber	1 10BASE-T or 1 100BASE-TX	1 T1/E1/J1
<b>7707ET-TE1-F2</b>	Dual Fiber	1 10BASE-T or 1 100BASE-TX	1 T1/E1/J1

Each version of the 7707ET is available with different output laser options to meet a variety of applications. (See specifications for complete information):

- 7707ET13** 1310 nm FP Laser
- 7707ETM13** 1310 nm FP Laser (Higher output power – see specs)
- 7707ET15** 1550 nm DFB Laser

There are sixteen versions with built in isolators specifically suited to coarse wave-division multiplexing (CWDM) applications.

- 7707ET27** 1270 nm DFB
- 7707ET29** 1290 nm DFB
- 7707ET31** 1310 nm DFB
- 7707ET33** 1330 nm DFB
- 7707ET35** 1350 nm DFB
- 7707ET37** 1370 nm DFB
- 7707ET43** 1430 nm DFB
- 7707ET45** 1450 nm DFB
- 7707ET47** 1470 nm DFB
- 7707ET49** 1490 nm DFB
- 7707ET51** 1510 nm DFB
- 7707ET53** 1530 nm DFB
- 7707ET55** 1550 nm DFB
- 7707ET57** 1570 nm DFB
- 7707ET59** 1590 nm DFB
- 7707ET61** 1610 nm DFB

The following chart shows some typical applications and power budget calculations.

Fiber Type	Fiber Links	Optical/Link Budget	Transmit Side		Receive Side		Description
			Ordering Product Info	TX Power	Ordering Product Info	RX Sensitivity	
Multi-Mode	2	< 3km	7707ET13-F2	-7dBm	7707ET13-F2	-28dBm	1310nm on Tx & Rx fibers
Single-Mode	2	21dB/50km	7707ET13-F2	-7dBm	7707ET13-F2	-28dBm	1310nm on Tx & Rx fibers
Single-Mode	1	14dB/30km*	7707ET13	-10dBm	7707ET13	-24dBm	1310nm, bi-directional, one fiber
Single-Mode	1(WDM)	25dB/60km	7707ET13M-W	-1dBm	7707ET15-W	-26dBm	1310nm/1550nm, WDM, bi-directional on one fiber
Single-Mode	1(CWDM)	24dB/80km**	7707ETxx-F2	0dBm	7707ETyy-F2	-28dBm	Different CWDM wavelengths on Tx & Rx, with 8 channel CWDM Mux/Demux**
Single-Mode	1(DWDM)	31dB/105km**	7707ETxxxx-F2	+7dBm	7707ETyyyy-F2	-28dBm	Different DWDM wavelengths on Tx & Rx, with 8 channel DWDM Mux/Demux**

\*With >20dB return loss on fiber Interface  
\*\*Assume 8 Ch Mux/Demux loss of 3.5dB

Tx Power/Rx Sensitivity are nominal values ± 1dBm  
Fiber Loss = 0.4/0.3dB per km @ 1310nm/1550nm

**Table 1-1: 7707ET Typical Application Configurations**

Fiber Type	Fiber Links	Optical/Link Budget	Transmit Side		Receive Side		Description
			Ordering Product Info	TX Power	Ordering Product Info	RX Sensitivity	
Multi-Mode	2	< 3km	7707ET13-TE1-F2	-7dBm	7707ET13-TE1-F2	-28dBm	1310nm on Tx & Rx fibers
Single-Mode	2	21dB/50km	7707ET13-TE1-F2	-7dBm	7707ET13-TE1-F2	-28dBm	1310nm on Tx & Rx fibers
Single-Mode	1	14dB/30km*	7707ET13-TE1	-10dBm	7707ET13-TE1	-24dBm	1310nm, bi-directional, one fiber
Single-Mode	1(WDM)	25dB/60km	7707ET13M-TE1-W	-1dBm	7707ET15-TE1-W	-26dBm	1310nm/1550nm, WDM, bi-directional on one fiber
Single-Mode	1(CWDM)	24dB/80km**	7707ETxx-TE1-F2	0dBm	7707ETyy-TE1-F2	-28dBm	Different CWDM wavelengths on Tx & Rx, with 8 channel CWDM Mux/Demux**
Single-Mode	1(DWDM)	31dB/105km**	7707ETxxxx-TE1-F2	+7dBm	7707ETyyyy-TE1-F2	-28dBm	Different DWDM wavelengths on Tx & Rx, with 8 channel DWDM Mux/Demux**

\*With >20dB return loss on fiber interface  
\*\*Assume 8 Ch Mux/Demux loss of 3.5dB

Tx Power/Rx Sensitivity are nominal values ± 1dB  
Fiber Loss = 0.4/0.3dB per km @ 1310nm/1550nm

**Table 1-2: 7707ET-TE1 Typical Application Configurations**

Fiber Type	Fiber Links	Optical/Link Budget	Transmit Side		Receive Side		Description
			Ordering Product Info	TX Power	Ordering Product Info	RX Sensitivity	
Multi-Mode	2	< 2km	7707ET13-4-F2	-7dBm	7707ET13-4-F2	-23dBm	1310nm on Tx & Rx fibers
Single-Mode	2	16dB/40km	7707ET13-4-F2	-7dBm	7707ET13-4-F2	-23dBm	1310nm on Tx & Rx fibers
Single-Mode	1	10dB/25km*	7707ET13-4	-9dBm	7707ET13-4	-19dBm	1310nm, bi-directional, one fiber
Single-Mode	1(WDM)	20dB/50km	7707ET13M-4-W	-1dBm	7707ET15-4-W	-21dBm	1310nm/1550nm, WDM, bi-directional on one fiber
Single-Mode	1(CWDM)	19dB/60km**	7707ETxx-4-F2	0dBm	7707ETyy-4-F2	-23dBm	Different CWDM wavelengths on Tx & Rx, with 8 channel CWDM Mux/Demux**
Single-Mode	1(CWDM)	24dB/80km**	7707ETxx-4-F2-H	0dBm	7707ETyy-4-F2-H	-28dBm	Different CWDM wavelengths on Tx & Rx, with 8 channel CWDM Mux/Demux**
Single-Mode	1(DWDM)	31dB/105km**	7707ETxxxx-4-F2	+7dBm	7707ETyyyy-4-F2	-23dBm	Different DWDM wavelengths on Tx & Rx, with 8 channel DWDM Mux/Demux**
Single-Mode	1(DWDM)	31dB/105km**	7707ETxxxx-4-F2-H	+7dBm	7707ETyyyy-4-F2-H	-28dBm	Different DWDM wavelengths on Tx & Rx, with 8 channel DWDM Mux/Demux**

\*With >20dB return loss on fiber interface  
\*\*Assume 8 Ch Mux/Demux loss of 3.5dB

Tx Power/Rx Sensitivity are nominal values ± 1dB  
Fiber Loss = 0.4/0.3dB per km @ 1310nm/1550nm

**Table 1-3: 7707ET-4 Typical Application Configurations**

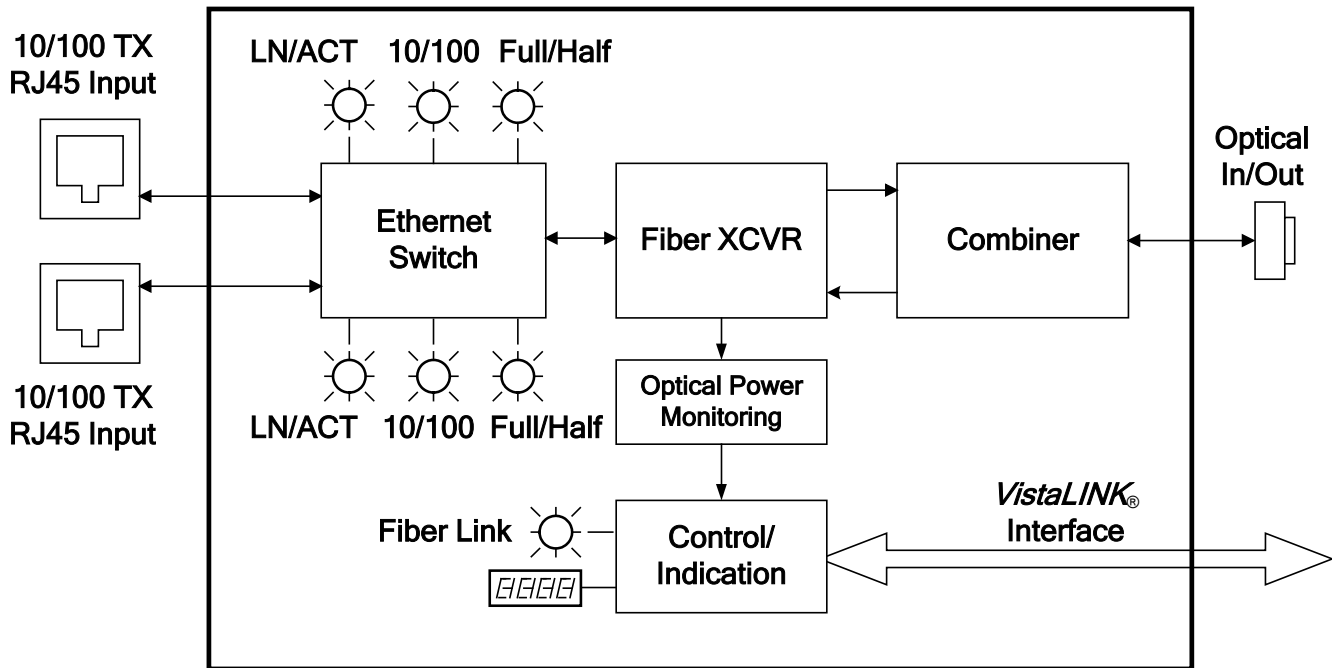

Figure 1-1: 7707ET Block Diagram

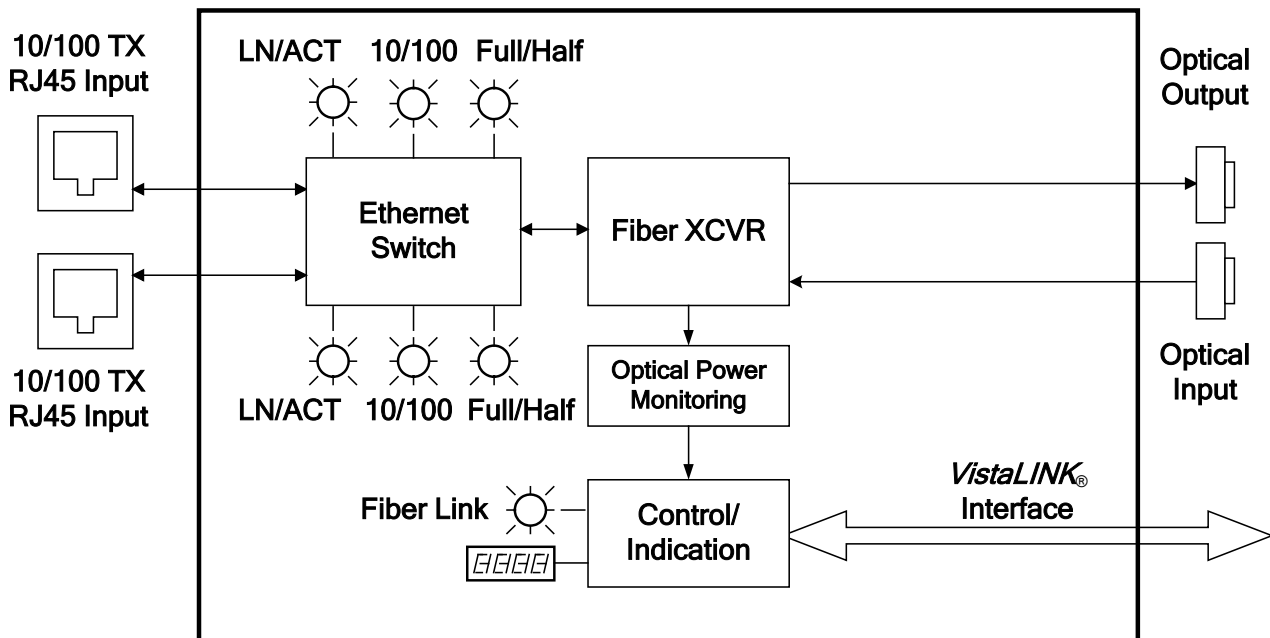
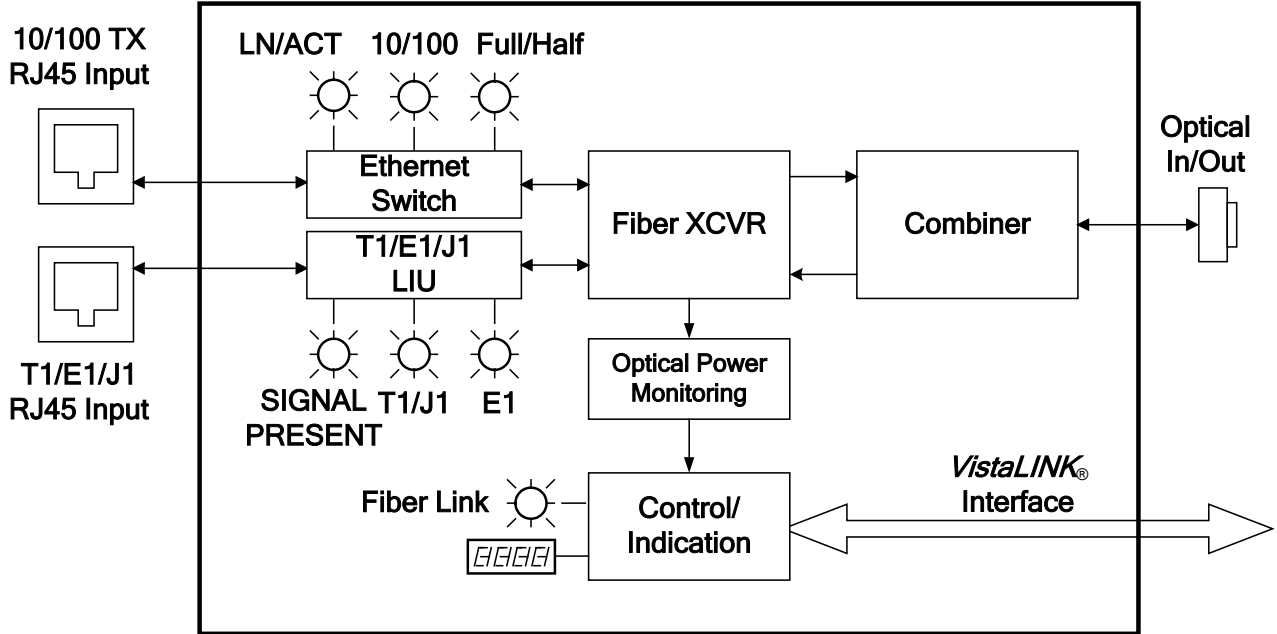
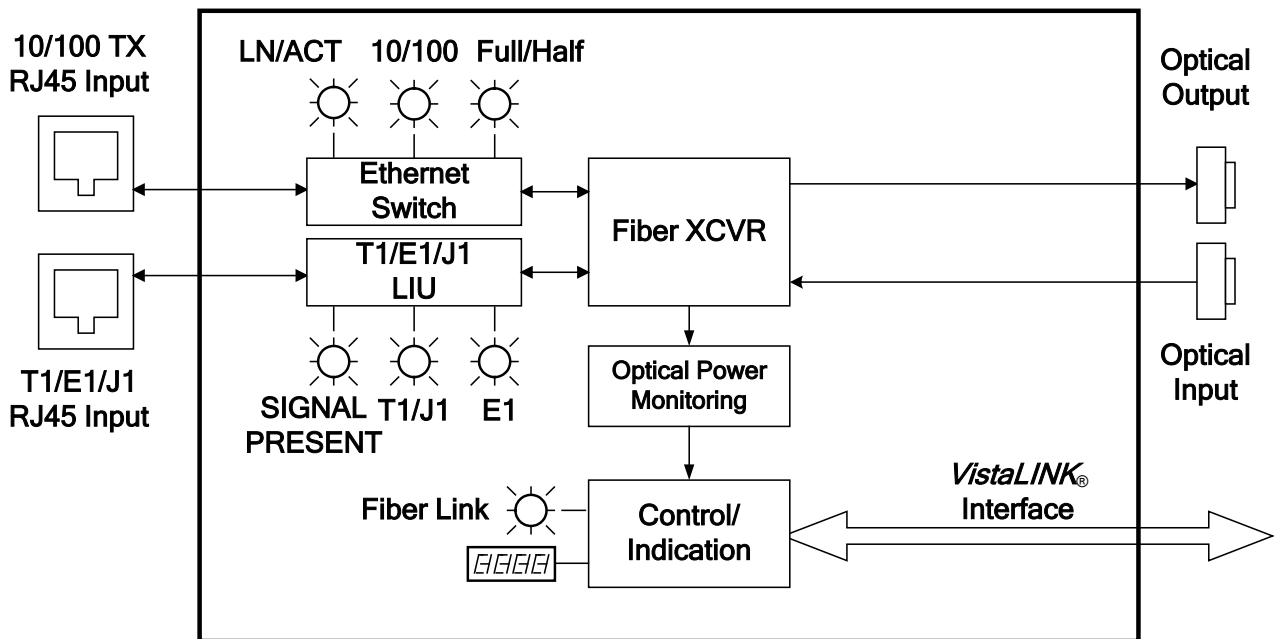

Figure 1-2: 7707ET-F2 Block Diagram





**Figure 1-3: 7707ET-TE1 Block Diagram**



**Figure 1-4: 7707ET-TE1-F2 Block Diagram**

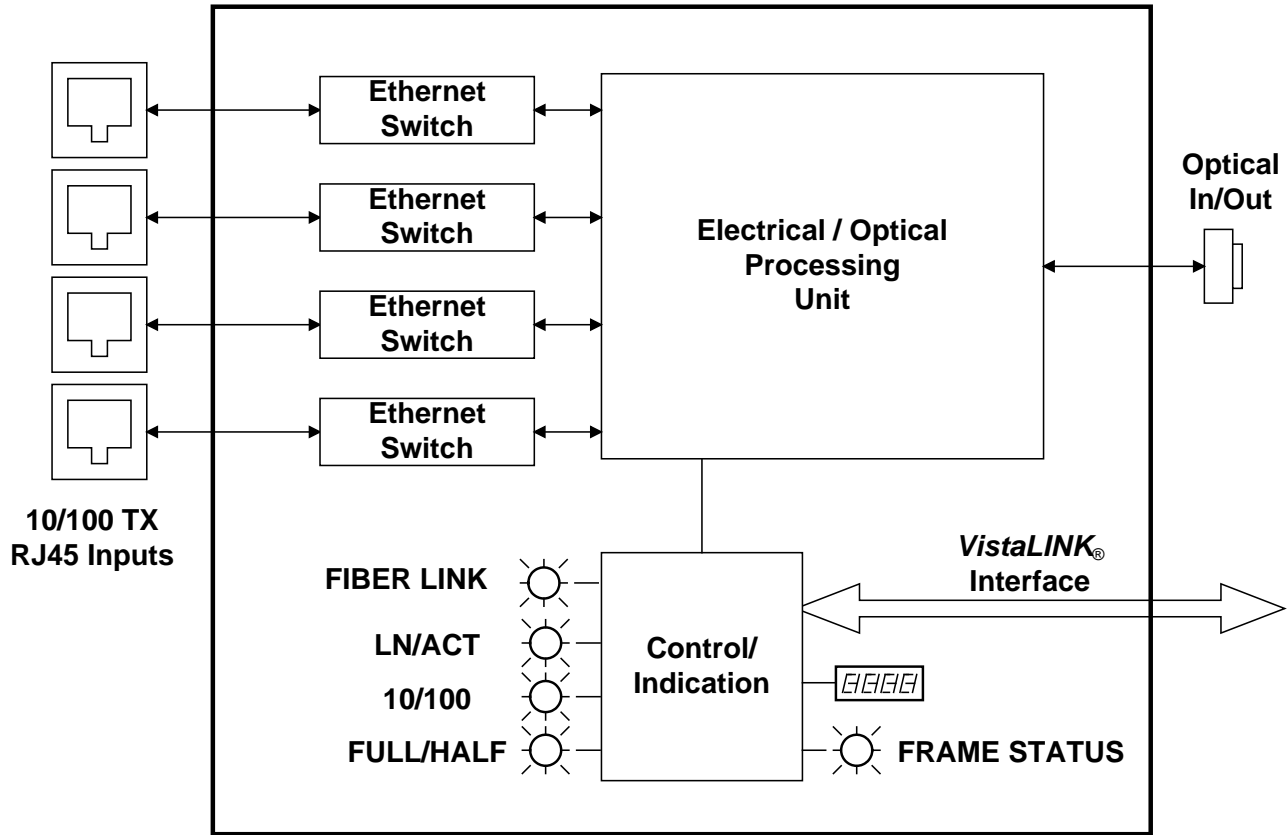
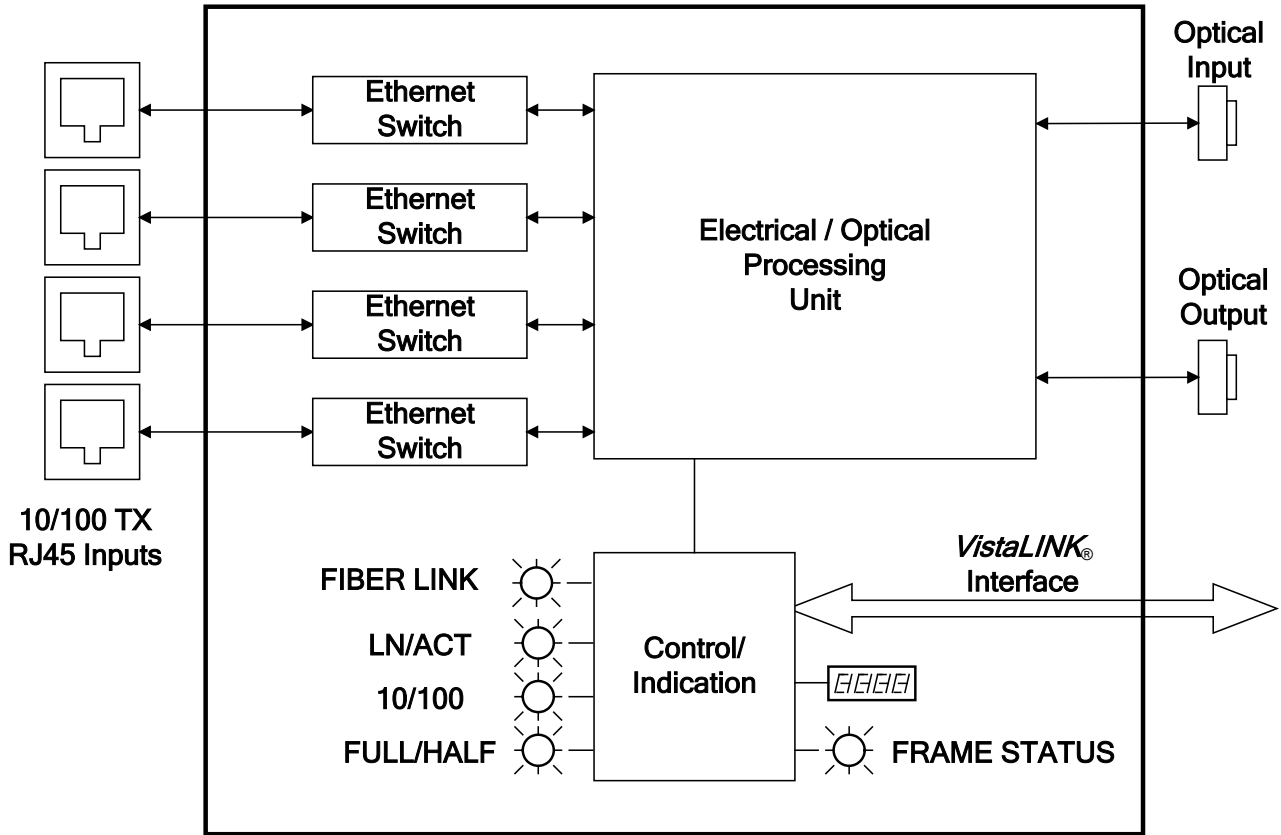

Figure 1-5: 7707ET-4 Block Diagram



**Figure 1-6: 7707ET-4-F2 Block Diagram**

## 2. INSTALLATION

The single fiber version 7707ET modules come with a companion rear plate that has two or four RJ45 input connectors and one SC/PC (shown), ST/PC or FC/PC optical connector. The dual fiber versions come with a companion rear plate that has two RJ45 input connectors and two SC/PC, ST/PC or FC/PC optical connectors. For information on mounting the rear plate and inserting the module into the frame see the 7700FR chapter section 3.

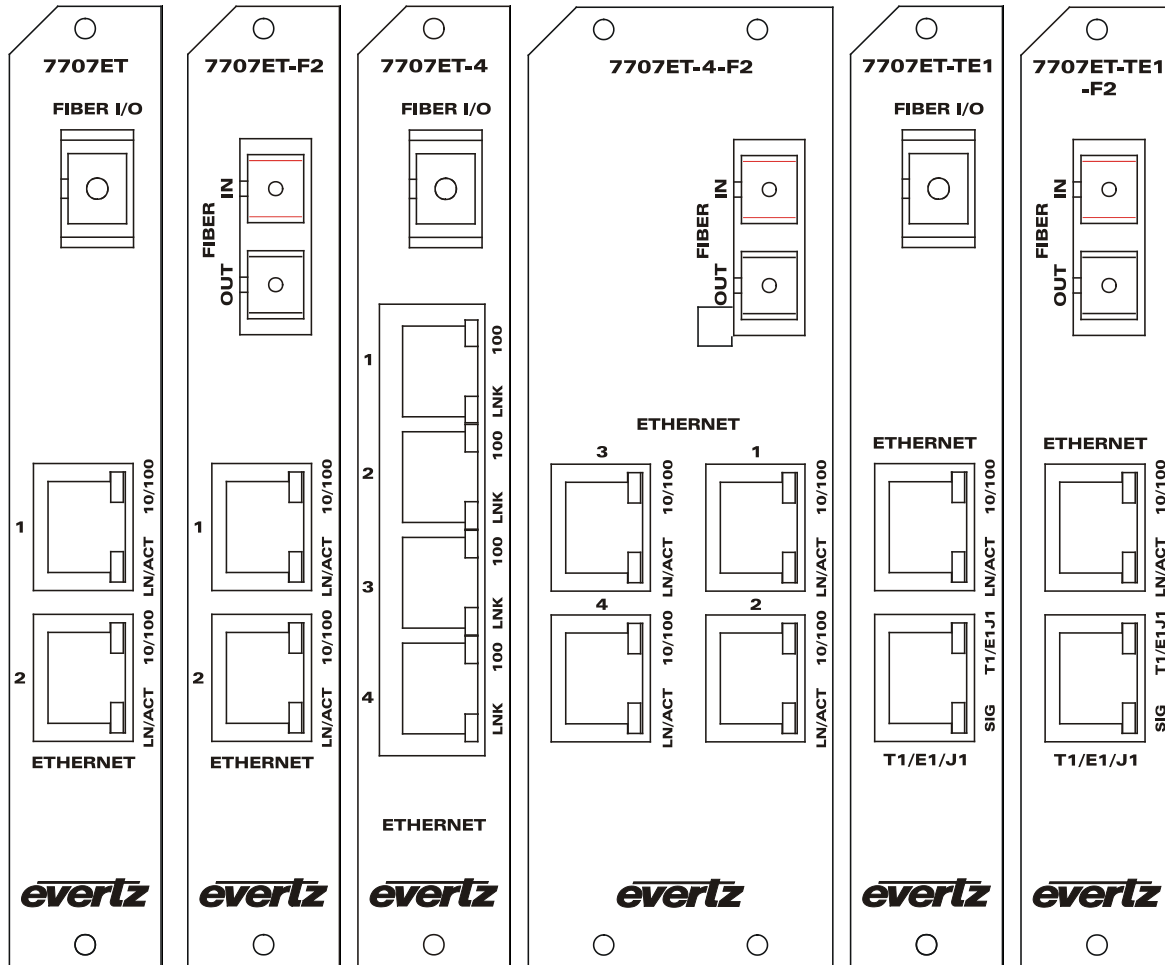

Figure 2-1: 7707ET Rear Panels

### 2.1. ETHERNET CONNECTIONS

The RJ-45 connectors on the rear panel are for connection to network devices (server, workstation, router switch, etc.) with a 10/100BASE-TX port through a twisted pair cable. On the 7707ET and 7707ET-F2, while both RJ-45 ports will auto-negotiate between 10 and 100 Mb/sec, the fiber port runs at only 100 Mb/sec. This means that while both RJ-45 ports can run at 100 Mb/sec at the same time, packets may be lost if both ports have a high traffic load. Therefore we recommend that only one RJ-45 port be used if it is to run at 100 Mb/sec. If you need to run both Ethernet ports at 100 Mb/sec then you will need to use the 7707ET-4 or 7707ET-4-F2 which has a 400 Mb/s fiber link and can handle four 100 Mb/sec Ethernet connections at the same time.

The 7707ET Ethernet Transceiver is designed for use with 10/100Base-TX twisted pair Ethernet cabling systems. When connecting for 100Base-TX systems, category 5 UTP cable is required. The maximum cable run between the Ethernet Fiber Transceiver and the supporting hub is 100 metres. Make the network connection by plugging one end of the cable into the RJ-45 receptacle of the Ethernet Fiber Transceiver and the other end into a port of the supporting hub.

When connecting the 7707ET to a hub or switch a “straight through” cable must be used. When connecting the 7707ET to the Evertz 7700FC VistaLINK<sup>®</sup> Frame Controller, another 7707ET, or the network interface card of a computer, a “crossover” cable must be used.

Pin #	Name	Cable Pair	Description
1	TX+	-----1a-----	Transmit + Output
2	TX-	-----1b-----	Transmit – Output
3	RX+	-----2a-----	Receive + Input
4	not used		
5	not used		
6	RX-	-----2b-----	Receive – Input
7	not used		
8	not used		

**Table 2-1: Ethernet Connector Pin Definitions and Cable Wiring**

Devices on the Ethernet network continually monitor the receive data path for activity as a means of checking that the link is working correctly. When the network is idle, the devices also send a carrier signal to one another to maintain the link. The 7707ET rear panel is fitted with two LEDs on each RJ-45 connector to monitor the Ethernet connection on each port.

**10/100:** This Green LED is On when a 100Base-TX link is established. The LED is Off when a 10Base-T link is established (the LINK LED is On) or if there is no link established (the LINK LED is Off). This LED should show the same information as the respective **10/100** LED on the card edge.

**LN/ACT:** This dual purpose Green LED indicates that the 7707ET has established a valid link, and whether the 7707ET is sending or receiving data. The LED will be On when the 7707ET has established a good link, providing a good indication that the segment is wired correctly. The LED will BLINK when the 7707ET is sending or receiving data. The LED will be Off if there is no valid connection.

## 2.2. T1/E1/J1 CONNECTIONS (TE1 VERSIONS ONLY)

On the 7707ET-TE1 and 7707ET-TE1-F2 versions, the lower RJ-45 connector on the rear panel is for connection to devices with a T1/E1/J1 port through a twisted pair cable. When connecting for T1/E1/J1 devices, 22 AWG (0.63mm) cable is required. The maximum cable run between the 7707ET-TE1 and the device is 1000 metres. Make the connection by plugging one end of the cable into the T1/E1/J1 RJ-45 receptacle of the Ethernet Fiber Transceiver and the other end into a port on the device.

Pin #	Name	Cable Pair	Description
1	Rx Ring	-----1a-----	Receive Ring Input
2	Rx Tip	-----1b-----	Receive Tip Input
3	not used		
4	Tx Ring	-----2a-----	Transmit Ring Output
5	Tx Tip	-----2b-----	Transmit Tip Output
6	not used		
7	not used		
8	not used		

**Table 2-2: T1/E1/J1 Connector Pin Definitions and Cable Wiring**

**T1/E1/J1:** This Red LED is On when a T1/J1 is the selected standard. The LED is Off when E1 is the selected standard. This LED may be green on some early production cards.

**SIG:** This Green LED indicates that a T1, E1 or J1 signal is present at the input. Standard selection does not effect this LED (i.e. with T1 selected an E1 signal will still cause this LED to light). This LED show's the same information as the **SIGNAL** LED on the card edge. This LED may be green on some early production cards.

### 2.3. OPTICAL CONNECTIONS



The 7707ET modules are designed to work with single-mode or multi-mode optical fiber depending on the version ordered.

#### 2.3.1. Single Fiber versions



In order to establish a valid link between a pair of single fiber 7707ET modules, one module must be configured as 'Address A', and the other as 'Address B'. Selection of the correct address is achieved by setting jumper J6. See section 5.4.

**FIBER I/O:** There is one SC/PC (shown), SC/PC with cover flap, ST/PC or FC/PC female connector with the optical input/output from the 7707ET. This connector should be connected to the matching connector of a matching single fiber 7707ET module at the destination end with a suitable fiber optic cable.

All single fiber versions of the 7707ET have their associated transmit wavelength marked on the rear panel and are designed to work with single-mode fiber optic cable.

### 2.3.2. Dual Fiber Versions (-F2 versions)

**FIBER IN:** There is one SC/PC (shown), ST/PC or FC/PC female connector with the optical input to the module. This connector should be connected to the FIBER OUT connector of a matching dual fiber 7707ET module at the destination end with a suitable fiber optic cable. The dual fiber 7707ET versions receive on wavelengths in the 1310 to 1610nm range.

**FIBER OUT:** There is one SC/PC (shown), ST/PC or FC/PC female connector with the optical output from the module. This connector should be connected to the FIBER IN connector of a matching dual fiber 7707ET module at the destination end with a suitable fiber optic cable. The dual fiber 7707ET versions transmit on the wavelength marked on the rear panel and are designed to work with either single-mode or multi-mode fiber optic cable.

## 2.4. CARE AND HANDLING OF OPTICAL FIBER

### 2.4.1. Safety



Background colour: yellow  
Triangular band: black  
Symbol: black

**CLASS 1 LASER PRODUCT**

### 2.4.2. Assembly

Assembly or repair of the laser sub-module is done only at Evertz facility and performed only by qualified Evertz technical personnel.

### 2.4.3. Labeling

Certification and Identification labels are combined into one label. As there is not enough room on the product to place the label it is reproduced here in the manuals.

- There is no date of manufacture on this label as it can be traced by bar code label placed on the Printed circuit board of each Evertz plug-in module
- The Model number is one of: 7707ET-13, 7707ET13M-W, 7707ET13-F2, 7707ET15-W, 7707ET-TE1, 7707ET13M-TE1-W, 7707ET15-TE1-W, 7707ET13-TE1-F2, 7707ET13-4, 7707ET13M-4-W, 7707ET15-4-W, 7707ET13-4-F2
- 7707ETxx (xx = 27, 29, 31, 33, 35, 37, 43, 45, 47, 49, 51, 53, 55, 57, 59, 61)  
7707ETDyyy (Dyyy represents ITU Grid Channel: D200, D210, D220, D230, D240, D250, D260, D270, D280, D290, D300, D310, D320, D330, D340, D350, D360, D370, D380, D390, D400, D410, D420, D430, D440, D450, D460, D470, D480, D490, D500, D510, D520, D530, D540, D550, D570, D580, D590, D600)



Figure 2-2: Reproduction of Laser Certification and Identification Label

#### 2.4.4. Handling and Connecting Fibers



**Never touch the end face of an optical fiber. Always keep dust caps on optical fiber connectors when not connected and always remember to properly clean the optical end face of a connector before making a connection.**

The transmission characteristics of the fiber are dependent on the shape of the optical core and therefore care must be taken to prevent fiber damage due to heavy objects or abrupt fiber bending. Evertz recommends that you maintain a minimum bending radius of 5 cm to avoid fiber-bending loss that will decrease the maximum attainable distance of the fiber cable. The Evertz fiber optic modules come with cable lockout devices, to prevent the user from damaging the fiber by installing a module into a slot in the frame that does not have a suitable I/O module. For further information about care and handling of fiber optic cable see section 3 of the Fiber Optics System Design chapter of this manual binder.



### 3. SPECIFICATIONS

#### 3.1. ETHERNET INPUT/OUTPUT

<b>Standard:</b>	IEEE 802.3 10BASE-T, 802.3u 100BASE-TX - auto-negotiation 10/100Mbps
<b>Connector:</b>	RJ-45
<b>Impedance:</b>	100 $\Omega$
<b>Number of Channels:</b>	
<b>7707ET, 7707ET-F2:</b>	2 10Base T or 1 100Base-TX (Max bandwidth is 100 Mb/sec – see section 2.1)
<b>7707ET-TE1, 7707ET-TE1-F2:</b>	1 10Base T or 1 100Base-TX
<b>7707ET-4, 7707ET-4-F2:</b>	4 10Base T or 100Base-TX
<b>Cable Requirements:</b>	
<b>10BASE-T:</b>	UTP category 3, 4, or 5 cable up to 328 ft/100m
<b>100BASE-TX:</b>	UTP category 5 cable up to 328 ft/100m

**Straight-through or Crossover cable:** Whether you use "straight-through" or "crossover cable" to connect to the 7707ET will depend on the device you are connecting to. When devices connect to each other on a network, they connect through a transmit and a receive line. When connecting the 7707ET to a hub or switch a "straight through" cable must be used. When connecting the 7707ET to the Evertz 7700FC VistaLINK<sup>®</sup> Frame Controller, another 7707ET, or the network interface card of a computer, a "crossover cable" must be used.

#### 3.2. T1/E1/J1 INPUT/OUTPUT (TE1 versions only)

<b>Standard:</b>	G.703 T1/E1/J1
<b>Connector:</b>	RJ-45 ports
<b>Number of Channels:</b>	1
<b>Cable Requirements:</b>	22 AWG (0.63mm) twisted pair cable is required (max. 1000 meters)

### **3.3. OPTICAL INPUT/OUTPUT**

**Connector:**

Single Fiber versions: 1 Bi-directional optical connector: SC/PC, SC/PC with cover flap, ST/PC or FC/PC female housing

Dual Fiber (F2) versions: 2 optical connector: SC/PC, ST/PC or FC/PC female housing

**Maximum Input Power:** 0 dBm

**Input Optical Sensitivity:**

Single fiber versions: -25 dBm

Dual fiber (F2) versions: -28 dBm

**Fiber Size and Type:**

Single Fiber versions: 9  $\mu$ m core / single mode

Dual Fiber (F2) versions: 9  $\mu$ m core / single-mode on TX, 62.5  $\mu$ m core / multi-mode on RX

**Output Wavelengths:**

Standard: 1310nm, 1550nm (nominal)

CWDM: 1270nm to 1610nm

**Output Power:**

**Single fiber versions:**

1310nm FP (Standard): -7.5 dBm  $\pm$ 1dBm

1310nm FP (M Version): -1.0 dBm  $\pm$ 1dBm

1550nm & CWDM DFB: -3.0 dBm  $\pm$ 1dBm

**Dual fiber versions:**

1310nm FP (Standard): -4.0 dBm  $\pm$ 1dBm

1310nm FP (M Version): 0 dBm  $\pm$ 1dBm

1550nm & CWDM DFB: 0 dBm  $\pm$ 1dBm

### **3.4. ELECTRICAL**

**Voltage:** + 12VDC

**Power:** 6 Watts

**EMI/RFI:** Complies with FCC regulations for class A devices  
Complies with EU EMC directive

### **3.5. PHYSICAL**

**7700 or 7701 frame mounting:**

Number of slots: 1

## 4. STATUS INDICATORS AND DISPLAYS

The 7707ET has LED Status indicators and a 4 digit alphanumeric display on the front card edge to show operational status of the card at a glance. There are also LED indicators on the RJ-45 connectors. Figure 5-1 to Figure 5-3 show the location of the LEDs.

### 4.1. STATUS INDICATOR LEDs

#### 4.1.1. Module Health LEDs

Two large LEDs on the front of the board indicate the general health of the module:

**LOCAL FAULT:** This Red LED indicates poor module health and will be On when there is insufficient optical input power, an optical transmitter failure or if a local input power fault exists (i.e.: a blown fuse). When the FRAME STATUS jumper is set to the ON position the LOCAL FAULT indication will also be reported to the FRAME STATUS bus.

**MODULE OK:** This Green LED indicates good module health. It will be On when a valid optical input signal is present, and the laser and board power are good.

#### 4.1.2. Fiber Link LED

The LED on the back of the board closest to the top card edge indicates the status of the Fiber link.

**FIBER LINK:** On the single fiber versions this Green LED indicates the presence of a valid optical link between a pair of 7707ET series single fiber modules.



**In order to establish a valid link between a pair of single fiber 7707ET modules, one module must be configured as 'Address A', and the other as 'Address B'. Selection of the correct address is achieved by setting jumper J6. See section 5.4.**

On the dual fiber versions this Green LED indicates that one 7707ET series dual fiber module has established a valid link with a similar 7707ET series dual fiber module, and whether the module is sending or receiving data on the fiber link. The LED will be ON when the module has established a good link, providing a good indication that the fiber segment is connected correctly. The LED will BLINK when the module is sending or receiving data. The LED will be OFF if there is no valid connection.

#### 4.1.3. Card Edge Ethernet LEDs

The three LEDs on the back side of the module closest to the center of the module indicate the status of the Ethernet 1 port. On the dual Ethernet versions (7707ET-4 and 7707ET-4-F2) these LEDs are assigned to one of the Ethernet ports using the toggle switch and LED Dot matrix display (See section 4.2.2). On the dual Ethernet versions (7707ET and 7707ET-F2) there are three LEDs on the front side of the module that indicate the status of the Ethernet 2 port.

- LN/ACT:** This dual purpose Green LED indicates that the module has established a valid Ethernet link, and whether the module is sending or receiving data on the respective Ethernet port. The LED will be ON when the module has established a good link, providing a good indication that the segment is wired correctly. The LED will BLINK when the module is sending or receiving data. The LED will be OFF if there is no valid connection. This LED should show the same information as the **LN/ACT** LED beside the respective RJ-45 connector on the rear panel
- 10/100:** This Green LED is On when a 100Base-TX link is established. The LED is Off when a 10Base-T link is established (the LINK LED is On) or if there is no link established (the LINK LED is Off). This LED should show the same information as the **10/100** LED beside the respective RJ-45 connector on the rear panel.
- HALF/FULL:** This Green LED is Off when the Ethernet link is operating in the half duplex mode, and On when it is operating in the Full duplex mode. In half duplex mode the LED will blink On when a collision occurs on the Ethernet link.

#### **4.1.4. Rear Panel Ethernet LEDs**

There are two LEDs adjacent to each of the Ethernet RJ-45 connectors on the rear panel that allow you to monitor the Ethernet connections while you are connected to the cables.

- LN/ACT:** This dual purpose Green LED indicates that the module has established a valid Ethernet link, and whether the module is sending or receiving data on the respective Ethernet port. The LED will be ON when the module has established a good link, providing a good indication that the segment is wired correctly. The LED will BLINK when the module is sending or receiving data. The LED will be OFF if there is no valid connection. This LED should show the same information as the respective **LN/ACT** LED on the card edge
- 10/100:** This Green LED is On when a 100Base-TX link is established. The LED is Off when a 10Base-T link is established (the LINK LED is On) or if there is no link established (the LINK LED is Off). This LED should show the same information as the respective **10/100** LED on the card edge.

#### **4.1.5. Card Edge T1/E1/J1 LEDs (TE1 Versions Only)**

The three LEDs on the front of the module near the dot matrix display indicate the status of the T1/E1/J1 port.

- SIGNAL:** This Green LED indicates that the T1, E1 or J1 signal is present at the input. Standard selection does not affect this LED (i.e. with T1 selected an E1 signal will cause this LED to light). This LED shows the same information as the **SIGNAL** LED beside the T1/E1/J1 RJ-45 connector on the rear panel.
- T1/J1:** This Green LED is On when T1/J1 is the standard selected. This LED will be On when the T1/E1/J1 LED beside the T1/E1/J1 RJ-45 connector on the rear panel is On.

**E1:** This Green LED is On when a E1 is the standard selected. This LED should be On when the T1/E1/J1 LED beside the T1/E1/J1 RJ-45 connector on the rear panel is Off.

#### 4.1.6. Rear Panel T1/E1/J1 LEDs (TE1 Versions Only)

There are two LEDs adjacent to each of the Ethernet RJ-45 connectors on the rear panel that allow you to monitor the Ethernet connections while you are connected to the cables.

**T1/E1/J1:** This Red LED is On when T1/J1 is the selected standard. The LED is Off when a E1 is the selected standard. This LED should show the same information as the **T1/J1** LED on the card edge. This LED may be green on some early production cards.

**SIG:** This Amber LED indicates that a T1, E1 or J1 signal is present at the input. This LED should show the same information as the **SIGNAL** LED on the card edge.

## 4.2. DOT-MATRIX DISPLAY

Additional status monitoring is provided via the 4-digit dot-matrix display located on the card edge. The card edge toggle switch is used to select which data is being displayed in the alphanumeric display. Each time the toggle switch is pressed up/down, the display advances to the next/previous display. A message indicating what display mode is active is shown for one second. After one second without the toggle switch being pressed, the selected display data is shown.

The following display messages indicate what is being displayed.

<b>PWR</b>	Input Optical Power
<b>EPT1</b>	LEDs show status for Ethernet port 1
<b>EPT2</b>	LEDs show status for Ethernet port 2
<b>EPT3</b>	LEDs show status for Ethernet port 3
<b>EPT4</b>	LEDs show status for Ethernet port 4

### 4.2.1. Displaying optical power

The 7707ET detects the input optical power and displays this on the four-digit card edge display. The following list describes possible displays.

<b>LOS</b>	Indicates no valid optical link established.
<b>OK</b>	Indicates optical input power is within acceptable range (> -10 dB for –FC versions, > -16 dB for –F2 versions).
<b>-10 to -25</b>	Numerical value of optical input power in dBm (-16 to –30 for –F2 version).

### 4.2.2. Displaying Ethernet Port Status (7707ET-4 and 7707ET-4-F2 only)

Use the toggle switch to select which Ethernet port the card edge LEDs are assigned to. See section 4.1.3 for information about the operation of the card edge LEDs.

## 5. JUMPERS AND USER ADJUSTMENTS

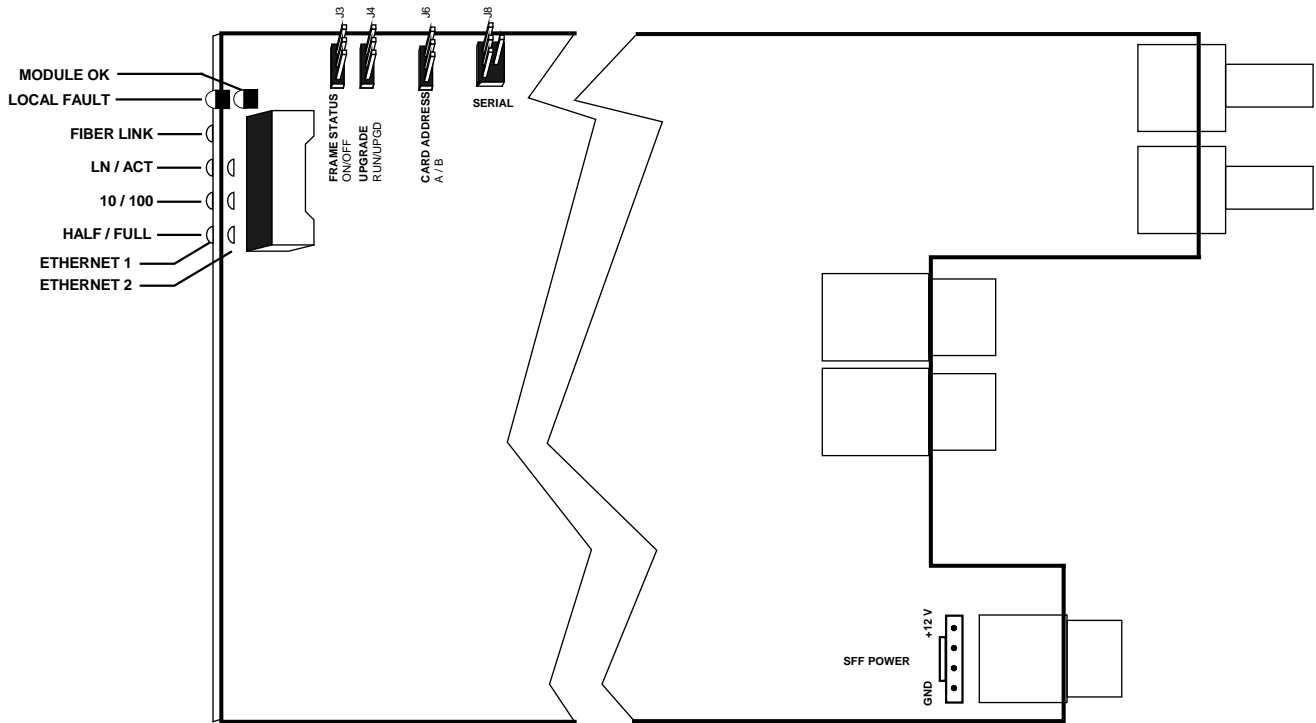

**Note:** standard version has one fiber connector, -F2 version has two fiber connectors

**Figure 5-1: LED and Jumper Locations (ET versions)**

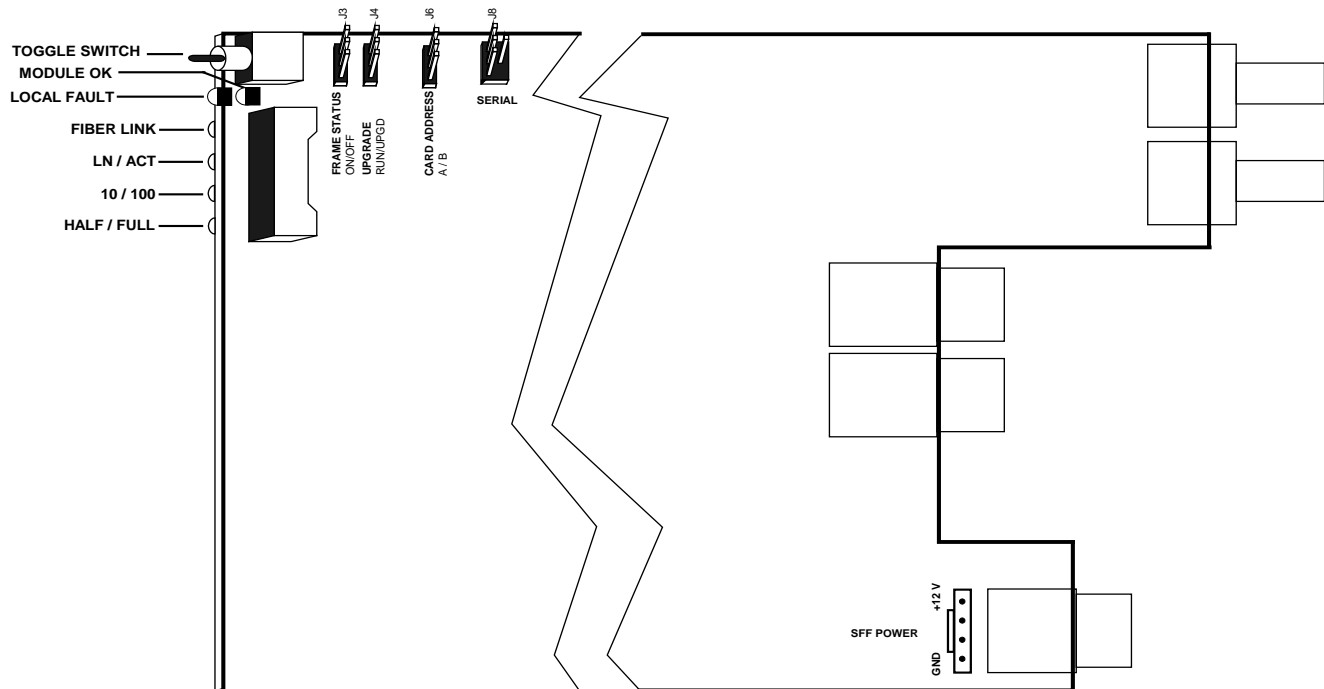

**Note:** standard version has one fiber connector; -F2 version has two fiber connectors

**Figure 5-2: LED and Jumper Locations (ET-4 versions)**

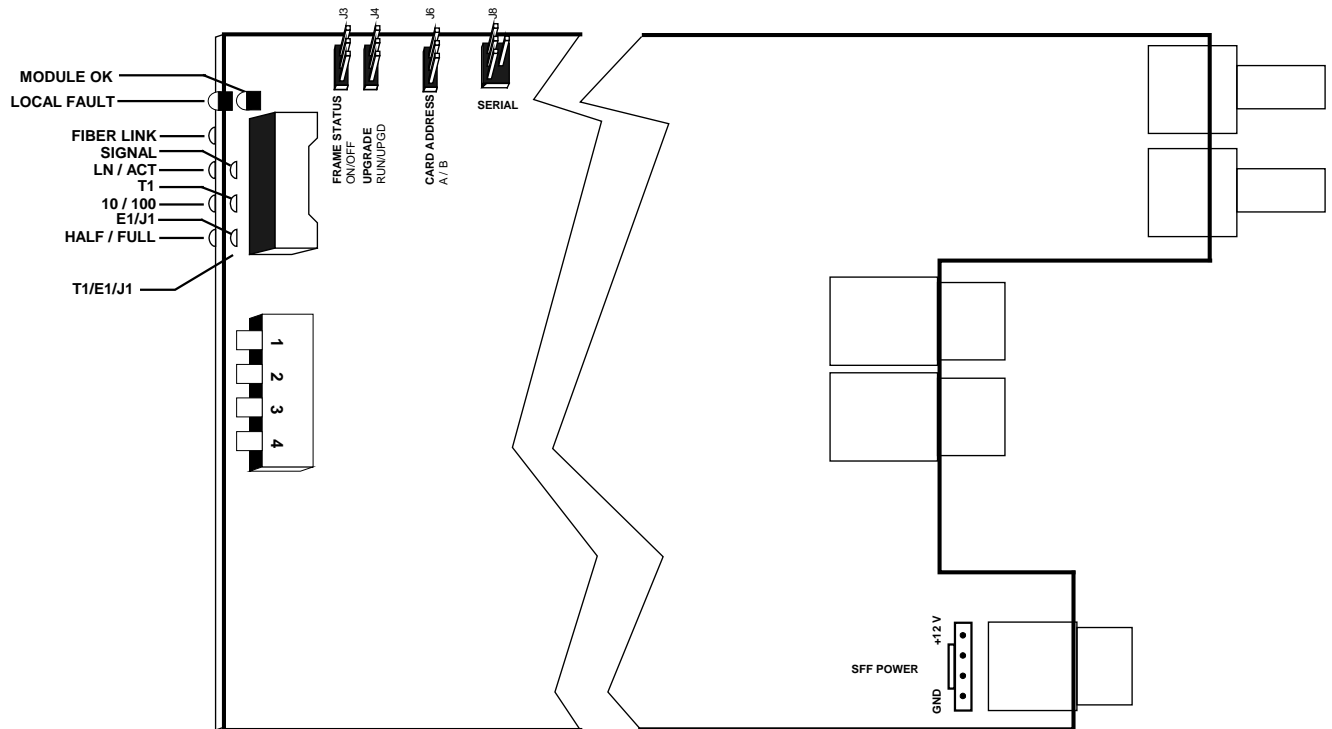

**Note:** standard version has one fiber connector; -F2 version has two fiber connectors

**Figure 5-3: LED and Jumper Locations (TE1 versions)**

**5.1. DIP SWITCH SETTINGS (TE1 VERSION ONLY)**

Only DIP switch one currently performs a function. The remaining three switches should remain in the “on” position for future upgrade compatibility.

DIP 1	T1/J1/E1 Selection
Off	E1 mode
On	T1/J1 mode

**5.2. SELECTING WHETHER LOCAL FAULTS WILL BE MONITORED BY THE GLOBAL FRAME STATUS**

The FRAME STATUS jumper J1 located at the front of the module determines whether local faults (as shown by the Local Fault indicator) will be connected to the 7700FR frame's global status bus.

**FRAME STATUS:** To monitor faults on this module with the frame status indicators (on the Power Supply FRAME STATUS LED's and on the Frame's Fault Tally output) install this jumper in the On position. (default)

When this jumper is installed in the Off position local faults on this module will not be monitored.

---

### **5.3. CONFIGURING THE MODULE FOR FIRMWARE UPGRADES**

**UPGRADE:** The UPGRADE jumper J4 is used when firmware upgrades are being done to the module. For normal operation it should be installed in the *RUN* position. See the *Upgrading Firmware* section in the front of the binder for more information.

To upgrade the firmware in the module unit pull it out of the frame. Move Jumper J4 into the *UPGRADE* position. Install the Upgrade cable provided (located in the vinyl pouch in the front of this manual) onto SERIAL header J8 at the top edge of the card. Re-install the module into the frame. Run the upgrade as described in the *Upgrading Firmware* section in the front of the binder. Once the upgrade is complete, remove the module from the frame, move J4 into the *RUN* position, remove the upgrade cable and re-install the module. The module is now ready for normal operation.

### **5.4. SELECTING THE CARD ADDRESS (SINGLE FIBER VERSION ONLY)**

The Card Address jumper allows each 7707ET module to distinguish its own signal, and that of a sister card at the other end of a fiber link. In the case of an incomplete or damaged fiber link each 7707ET module will see reflections or its own signal. In order to establish a valid link between a pair of 7707ET modules, one module must be configured as 'Address A', and the other as 'Address B'. Selection of the correct mode is achieved by setting jumper J6, at the front of the board. It does not matter which card is selected as Address A and which as Address B, as long as they are different.



## 6. VISTALINK<sup>®</sup> REMOTE MONITORING/CONTROL

### 6.1. WHAT IS VISTALINK<sup>®</sup>?

VistaLINK<sup>®</sup> is Evertz's remote monitoring and configuration platform which operates over an Ethernet network using Simple Network Management Protocol (SNMP). SNMP is a standard computer network protocol that enables different devices sharing the same network to communicate with each other. VistaLINK<sup>®</sup> provides centralized alarm management, which monitors, reports, and logs all incoming alarm events and dispatches alerts to all the VLPro Clients connected to the server. Card configuration through VistaLINK<sup>®</sup> PRO can be performed on an individual or multi-card basis using simple copy and paste routines, which reduces the time to configure each module separately. Finally, VistaLINK<sup>®</sup> enables the user to configure devices in the network from a central station and receive feedback that the configuration has been carried out.

There are 3 components of SNMP:

1. An SNMP manager, also known as a Network Management System (NMS), is a computer running special software that communicates with the devices in the network. Evertz VL-Fiber demo Manager graphical user interface (GUI), third party or custom manager software may be used to monitor and control Evertz *VistaLINK<sup>®</sup>* enabled fiber optic products.
2. Managed devices (such as 7707ET), each with a unique address (OID), communicate with the NMS through an SNMP Agent. Evertz *VistaLINK<sup>®</sup>* enabled 7700 series modules reside in the 3RU 7700FR-C MultiFrame and communicate with the manager via the 7700FC *VistaLINK<sup>®</sup>* frame controller module, which serves as the Agent.
3. A virtual database, known as the Management information Base (MIB), lists all the variables being monitored and which both the Manager and Agent understand. Please contact Evertz for further information about obtaining a copy of the MIB for interfacing to a third party Manager/NMS.

For more information on connecting and configuring the *VistaLINK<sup>®</sup>* network, see the 7700FC Frame Controller chapter.

## 6.2. VISTALINK® MONITORED PARAMETERS

The following parameters can be remotely monitored through the VistaLINK® interface.

Parameter	Description
<b>Link OK</b>	Indicates presence of a valid optical link with another 7707ET module (the state of the FIBER LINK LED)
<b>Optical Power</b>	A range of values describing received optical power at the fiber input.
<b>Ethernet 1 Link</b>	Indicates the presence of a valid link on the Ethernet 1 port. (the state of the ETHERNET 1 LN/ACT LED)
<b>Ethernet 1 Speed</b>	Indicates the detected speed of the link on the Ethernet 1 port. (the state of the ETHERNET 1 10/100 LED)
<b>Ethernet 1 Mode</b>	Indicates whether the Ethernet 1 port is operating in the half duplex or full duplex mode. (the state of the ETHERNET 1 HALF/FULL LED)
<b>Ethernet 2 Link</b>	Indicates the presence of a valid link on the Ethernet 2 port. (the state of the ETHERNET 2 LN/ACT LED) ET and ET-4 versions only.
<b>Ethernet 2 Speed</b>	Indicates the detected speed of the link on the Ethernet 2 port. (the state of the ETHERNET 2 10/100 LED) ET and ET-4 versions only.
<b>Ethernet 2 Mode</b>	Indicates whether the Ethernet 2 port is operating in the half duplex or full duplex mode. (the state of the ETHERNET 2 HALF/FULL LED) ET and ET-4 versions only.
<b>Ethernet 3 Link</b>	Indicates the presence of a valid link on the Ethernet 3 port. (the state of the ETHERNET 3 LN/ACT LED) ET-4 version only.
<b>Ethernet 3 Speed</b>	Indicates the detected speed of the link on the Ethernet 3 port. (the state of the ETHERNET 3 10/100 LED) ET-4 version only.
<b>Ethernet 3 Mode</b>	Indicates whether the Ethernet 3 port is operating in the half duplex or full duplex mode. (the state of the ETHERNET 3 HALF/FULL LED) ET-4 versions only.
<b>Ethernet 4 Link</b>	Indicates the presence of a valid link on the Ethernet 4 port. (the state of the ETHERNET 4 LN/ACT LED) ET-4 version only.
<b>Ethernet 4 Speed</b>	Indicates the detected speed of the link on the Ethernet 4 port. (the state of the ETHERNET 4 10/100 LED) ET-4 version only.
<b>Ethernet 4 Mode</b>	Indicates whether the Ethernet 4 port is operating in the half duplex or full duplex mode. (the state of the ETHERNET 4 HALF/FULL LED) ET-4 version only.
<b>T1/E1/J1 Signal Present</b>	Indicates the presence of a valid T1/E1/J1 signal on the T1/E1/J1 port. (the state of the SIGNAL LED) TE1 version only.
<b>T1/E1/J1 Signal Type</b>	Indicates the type of signal on the T1/E1/J1 port. (the state of the T1/E1J1 LED) TE1 version only.
<b>Card Address</b>	Indicates the state of the CARD ADDRESS jumper. On –F2 versions it always returns a value of zero.

**Table 6-1: VistaLINK® Monitored Parameters**

## 6.3. VISTALINK® CONTROLLED PARAMETERS

There are no parameters that can be controlled through the VistaLINK® interface.