

## TABLE OF CONTENTS

1. OVERVIEW .....	1
2. INSTALLATION .....	3
2.1. 7702 / 7703LPS-2 / 7803LPS-2 CONNECTIONS.....	4
3. 7702 / 7703LPS-2 SPECIFICATIONS .....	5
3.1. RF INPUT.....	5
3.2. RF OUTPUT.....	5
3.3. LNB VOLTAGE.....	5
3.4. ELECTRICAL.....	5
3.5. PHYSICAL .....	5
4. STATUS INDICATORS .....	6
4.1. MODULE OK / FAULT .....	6
4.2. LNB STATUS.....	6
4.3. RF LEVEL INDICATOR .....	6
5. USER CONTROLS .....	7
5.1. SHORT CIRCUIT/OVERLOAD PROTECTION MODES .....	7
5.2. DIP SWITCH CONTROL.....	8
5.2.1. 7702LPS-2 DIP Switch Control.....	8
5.2.2. 7703LPS-2 / 7803LPS-2 DIP Switch Control .....	9
5.3. CARD EDGE INTERFACE (7703/7803 VERSIONS ONLY).....	10
5.3.1. CTRL – (Control) MENU STRUCTURE .....	10
5.3.1.1. LNBV Control.....	10
5.3.1.2. 22kHz Tone Control.....	10
5.3.1.3. Short Circuit Mode Control .....	11
5.3.1.4. LNB STATIC Mode Short Circuit/Overload Reset Control .....	11
5.3.1.5. Dot Matrix Display Control.....	11
5.3.2. STAT – (Status) MENU STRUCTURE.....	11
5.3.2.1. LNB Voltage Monitoring.....	12
5.3.2.2. LNB Current Monitoring.....	12
5.3.2.3. RF Power Monitoring.....	12
5.3.2.4. VER Monitoring .....	12
6. JUMPER CONTROLS.....	13
6.1. SELECTING WHETHER LOCAL FAULTS WILL BE MONITORED BY THE GLOBAL FRAME STATUS .....	13
6.2. CONFIGURING THE MODULE FOR FIRMWARE UPGRADES.....	13
7. VISTALINK® REMOTE MONITORING/CONTROL (7703/7803 ONLY).....	14
7.1. WHAT IS VISTALINK®?.....	14

---

7.2.	VISTALINK® MONITORED PARAMETERS .....	15
7.3.	VISTALINK® CONTROLLED PARAMETERS .....	15
7.4.	VISTALINK® TRAPS.....	15
8.	APPENDIX A .....	16
8.1.	HARDWARE OPTIONS .....	16

**Figures**

Figure 1-1: 7702/3LPS-2 and 7803LPS-2 Block Diagram .....	2
Figure 2-1: 7702 / 7703LPS-2 / 7803LPS-2 3RU Rear Panels.....	3

**Tables**

Table 5-1: DIP Switch Functionality for 7702LPS-2 .....	8
Table 5-2: DIP Switch Functionality for 7703/7803 LPS-2.....	9
Table 7-1: VistaLINK® Monitored Parameters.....	15
Table 7-2: VistaLINK® Controlled Parameters .....	15
Table 7-3: VistaLINK®Traps .....	15

## REVISION HISTORY

<u>REVISION</u>	<u>DESCRIPTION</u>	<u>DATE</u>
1.0	First Release	Jan 07
1.1	Updated DIP switch settings, spec updates, and minor corrections Added section 5.1 on short circuit/overload protection modes	Oct 07
1.2	Updated formatting and specifications	Oct 09
1.3	Added the 7803LPS-2 product and specs	Jan 15

Information contained in this manual is believed to be accurate and reliable. However, Evertz assumes no responsibility for the use thereof nor for the rights of third parties, which may be effected in any way by the use thereof. Any representations in this document concerning performance of Evertz products are for informational use only and are not warranties of future performance, either express or implied. The only warranty offered by Evertz in relation to this product is the Evertz standard limited warranty, stated in the sales contract or order confirmation form.

Although every attempt has been made to accurately describe the features, installation and operation of this product in this manual, no warranty is granted nor liability assumed in relation to any errors or omissions unless specifically undertaken in the Evertz sales contract or order confirmation. Information contained in this manual is periodically updated and changes will be incorporated into subsequent editions. If you encounter an error, please notify Evertz Customer Service department. Evertz reserves the right, without notice or liability, to make changes in equipment design or specifications.

## CAUTION

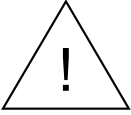

If the LNB STATUS LED is green, there will be DC voltage for LNB power at the RF IN connector. This can damage some test equipment.

## 1. OVERVIEW

The 7702LPS-2, 7703LPS-2 & 7803LPS-2 dual port LNB power inserters offer a modular, high performance and compact platform for inserting DC power via coaxial cable to two LNBs. Housed in the 7800FR 3RU frame with dual power supplies, up to 30 (7702) or 28 (7703, 7803) LNBs can be powered with a single frame. On their RF input connectors, the cards provide +13/+18V DC power and 22kHz tone generation with low RF insertion loss. The 7703 and 7803 versions include SNMP support for remote monitoring and control via VistaLINK<sup>®</sup> software, including LNB current and RF input power monitoring. The 7702LPS-2, 7703LPS-2 & 7803LPS-2 each occupy one card slot and can be housed in a 1RU frame which will hold up to three modules, a 3RU frame which will hold up to 15 modules, a 350FR portable frame, which will hold up to seven modules, or a standalone frame that will hold 1 module.

### Features:

- Provide DC voltage of +13/+18V DC with available +1V DC (+14/+19V DC) cable compensation for long cable runs
- 22kHz tone generation available on both ports for LNB control
- DC voltage level and 22kHz tone generation are independently controllable on each port
- Dynamic or static short circuit current protection. Dynamic mode features continuous short circuit check and automatic recovery, while static mode disables DC voltage until a reset is performed. Both modes indicate the short circuit condition on card edge LEDs and VistaLINK<sup>®</sup> (7703 version)
- For system diagnostics and troubleshooting, the 7703 version provides RF input power and LNB current monitoring with adjustable thresholds for SNMP/VistaLINK<sup>®</sup> alarming
- 7800FR frame power supplies are redundant, front-loading and hot swappable for reliability and ease of maintenance
- 7803LPS-2 provides extra current capacity to supply high demand LNB's or additional series devices such as fiber optic transmitters
- 7702 and 7703 and 7803 cards are front loading and hot swappable for simple installation and maintenance
- 7703 and 7803 cards feature full SNMP/VistaLINK<sup>®</sup> support and local card edge monitoring and control via the dot matrix display and toggle switch/pushbutton

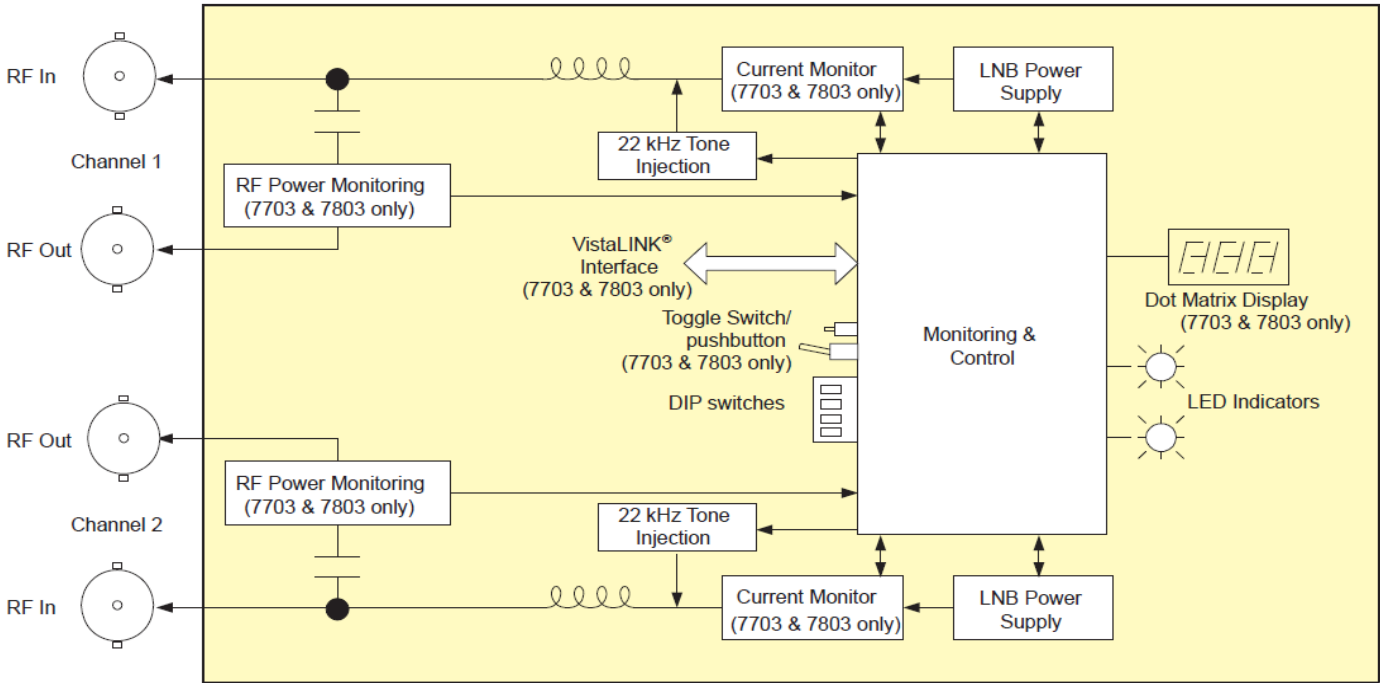

Figure 1-1: 7702/3LPS-2 and 7803LPS-2 Block Diagram

## 2. INSTALLATION

The 7702/3LPS-2 and 7803LPS-2 comes with a companion rear plate that has four BNC (F type optional) connectors. For information on mounting the rear plate and inserting the module into the frame see section 3 of the 7700FR chapter. Figure 2-1 illustrates the different rear panels which is used for installation in the 7700FR or 7800 frame.

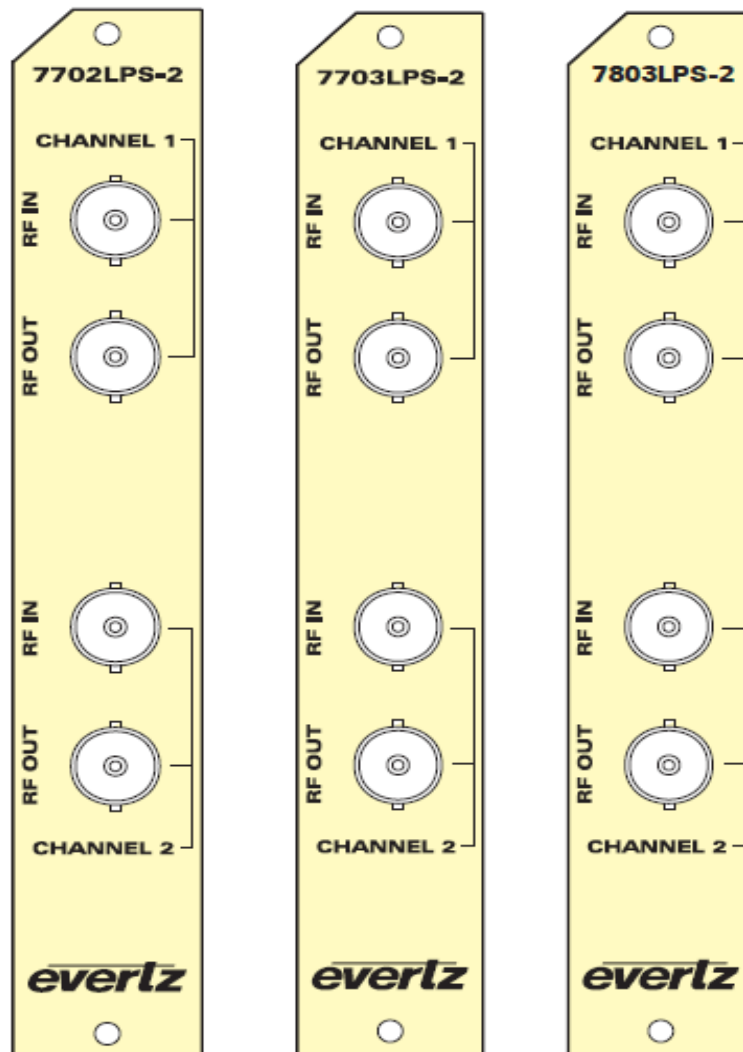

Figure 2-1: 7702 / 7703LPS-2 / 7803LPS-2 3RU Rear Panels

## 2.1. 7702 / 7703LPS-2 / 7803LPS-2 CONNECTIONS

**RF IN:** Input BNC (F-Type and SMA optional) connector that accepts RF input from an LNB while providing DC power back to the LNB.



**If the LNB STATUS LED is green, there will be DC voltage for LNB power at the RF IN connector. This can damage some test equipment.**

**RF OUT:** Output BNC (F-Type and SMA optional) connector provides RF signal while blocking the DC voltage provided to the LNB.



### 3. 7702 / 7703LPS-2 SPECIFICATIONS

#### 3.1. RF INPUT

<b>Connector:</b>	BNC per IEC 61169-8 Annex A (F type and SMA connector optional)
<b>I/O Impedance:</b>	75 $\Omega$ , 50 $\Omega$ optional
<b>Return Loss:</b>	>15dB
<b>Isolation:</b>	> 60dB
<b>Input Frequency Range:</b>	250MHz – 2250MHz
<b>Input Power Range:</b>	0 to –70dBm

#### 3.2. RF OUTPUT

<b>Connector:</b>	BNC (F type optional and SMA connector optional)
<b>I/O Impedance:</b>	75 $\Omega$ , 50 $\Omega$ optional
<b>Return Loss:</b>	>15dB
<b>Output Frequency Range:</b>	250MHz – 2250MHz
<b>Insertion Loss:</b>	<1.6dB
<b>Frequency Response:</b>	+/- 0.2dB

#### 3.3. LNB VOLTAGE

<b>Output Voltage:</b>	+13, +14, +18, +19Vdc
<b>Maximum Output Current:</b>	400mA (7702 &7703) 600mA (7803)

#### 3.4. ELECTRICAL

<b>Voltage:</b>	+12VDC
<b>Power:</b>	3 Watts with no LNB load
<b>EMI/RFI:</b>	Complies with FCC regulations for class A devices Complies with EU EMC directive.

#### 3.5. PHYSICAL

<b>7700 / 7701 / 7800FR / 7801FR frame mounting:</b>	
<b>Number of slots:</b>	1

## 4. STATUS INDICATORS

The 7702/3LPS-2 and 7803LPS-2 has two module status LEDs and four smaller edge operational status LEDs for monitoring and diagnostics at a glance.

### 4.1. MODULE OK / FAULT

There is one red and one green large LED located at the top of the PCB when inserted into the frame. Only one of these LEDs will be on at any time.

**MODULE OK:** This green LED will be ON to indicate overall module health.

**FAULT:** This red LED will be ON when there is a fuse failure or the LNB voltage on one port is below the desired level.

### 4.2. LNB STATUS

There are two small LEDs at the top of the PCB that indicate the LNB status on each side of the PCB. The CH1 LNB status LED is on the DIP switch side of the PCB and the CH2 LNB status LED is on the opposite side.

**LNB SHORT:** The LNB status LED will be red when a short circuit condition is present on the RF IN port providing the LNB voltage.

**LNB POWER ON:** The LNB status LED will be green when the LNB DC voltage is present at the RF IN port.

**LNB POWER OFF:** The LNB status LED will be OFF when the LNB DC voltage is turned OFF.



**If the LNB STATUS LED is green, there will be DC voltage for LNB power at the RF IN connector. This can damage some test equipment.**

### 4.3. RF LEVEL INDICATOR

There are two small LEDs at the top of the PCB that indicate the RF LEVEL status on each side of the PCB just below the LNB STATUS LEDs mentioned in section 4.2. The CH1 RF LEVEL status LED is on the DIP switch side of the PCB and the CH2 RF LEVEL status LED is on the opposite side.

**RF HIGH:** The RF LEVEL LED will be red when the RF level is above the RF HIGH threshold. The default level is 0dBm.

**RF OK:** The RF LEVEL LED will be green when the RF level is above the RF LOW threshold and below the RF HIGH threshold.

**RF LOW:** The RF LEVEL LED will be orange when the RF level is below the RF LOW threshold.

## 5. USER CONTROLS

The 7703LPS-2 or 7803LPS-2 can be controlled using either the card edge control and SNMP or through the octal DIP switch located on the top of the PCB. The selection of these two control methods is provided by DIP switch 8.

The 7702LPS-2 is controlled via the octal DIP switch. There is no card edge interface (dot matrix display, pushbutton, and toggle switch).

### 5.1. SHORT CIRCUIT/OVERLOAD PROTECTION MODES

The 7702 and 7703LPS-2 and 7803LPS-2 offer two modes of short circuit/overload protection in the event of LNB failure, cable fault or other short circuit or overload events.

**DYNAMIC:** When in dynamic mode, the card will periodically apply power to the LNB load to determine if the short circuit/overload condition has been corrected. When the short circuit/overload has been removed, LNB power will automatically be restored.

**STATIC:** In static mode, when a short circuit or overload condition is encountered, LNB output voltage will remain switched off until such time as a user-reset is performed on the card.

Descriptions of how to select the desired protection mode and how to perform a reset when in static mode are provided in the following sections.

## 5.2. DIP SWITCH CONTROL

### 5.2.1. 7702LPS-2 DIP Switch Control

The octal DIP switch is located on the top of the PCB. These switches are the method of control on the 7702LPS-2. Table 5-1 illustrates the function of each switch.

DIP Switch 1	ON	LNB POWER ON Port 1	Also performs LNB reset by toggling after a short occurs in STATIC mode.
	OFF	LNB POWER OFF Port 1	
DIP Switch 2	ON	LNB port 1 voltage = +18Vdc	This switch is valid only when DIP Switch 1 is ON.
	OFF	LNB port 1 voltage = +13Vdc	
DIP Switch 3	ON	22kHz tone port 1 ON	This switch is valid only when DIP Switch 1 is ON.
	OFF	22kHz tone port 1 OFF	
DIP Switch 4	ON	Dynamic Short circuit mode	Short circuit/overload protection mode on PORT 1
	OFF	Static Short circuit mode	
DIP Switch 5	ON	LNB POWER ON Port 2	Also performs LNB reset by toggling after a short occurs in STATIC mode.
	OFF	LNB POWER OFF Port 2	
DIP Switch 6	ON	LNB port 2 voltage = +18Vdc	This switch is valid only when DIP Switch 5 is ON.
	OFF	LNB port 2 voltage = +13Vdc	
DIP Switch 7	ON	22kHz tone port 2 ON	This switch is valid only when DIP Switch 5 is ON.
	OFF	22kHz tone port 2 OFF	
DIP Switch 8	ON	Dynamic Short circuit mode	Short circuit/overload protection mode on PORT 2
	OFF	Static Short circuit mode	

**Table 5-1: DIP Switch Functionality for 7702LPS-2**

### 5.2.2. 7703LPS-2 / 7803LPS-2 DIP Switch Control

The octal DIP switch is located on the top of the PCB. DIP switch 8 selects the control mode, which may be LOCAL or SNMP. In LOCAL control mode, the DIP switches are used to control the card. In SNMP control mode, the card edge interface or SNMP can simultaneously be used to control the card and the DIP switch settings (other than switch 8) are ignored.

DIP Switch 1	ON	LNB POWER ON Port 1	Also performs LNB reset by toggling after a short/overload occurs in STATIC mode.
	OFF	LNB POWER OFF Port 1	
DIP Switch 2	ON	LNB port 1 voltage = +18Vdc	This switch is valid only when DIP Switch 1 is ON.
	OFF	LNB port 1 voltage = +13Vdc	
DIP Switch 3	ON	22kHz tone port 1 ON	This switch is valid only when DIP Switch 1 is ON.
	OFF	22kHz tone port 1 OFF	
DIP Switch 4	ON	LNB POWER ON Port 2	Also performs LNB reset by toggling after a short/overload occurs in STATIC mode.
	OFF	LNB POWER OFF Port 2	
DIP Switch 5	ON	LNB port 2 voltage = +18Vdc	This switch is valid only when DIP Switch 4 is ON.
	OFF	LNB port 2 voltage = +13Vdc	
DIP Switch 6	ON	22kHz tone port 2 ON	This switch is valid only when DIP Switch 4 is ON.
	OFF	22kHz tone port 2 OFF	
DIP Switch 7	ON	Dynamic Short circuit mode	Selects short circuit/overload protection mode – applies to both ports.
	OFF	Static Short circuit mode	
DIP Switch 8	ON	SNMP CONTROL	Applicable only for 7703LPS-2
	OFF	LOCAL CONTROL	

**Table 5-2: DIP Switch Functionality for 7703/7803 LPS-2**

### 5.3. CARD EDGE INTERFACE (7703/7803 VERSIONS ONLY)

The card edge interface (toggle switch, push button and dot matrix display) is available on the 7703LPS-2 and 7803LPS-2 for control. The user menus in this interface are detailed below. In local control mode, only the STAT menu will be available through this interface. In normal operation, the display will show OK. Upon pressing the pushbutton, the top level menu is entered and the selections are BACK, STAT and CTRL.

#### 5.3.1. CTRL – (Control) MENU STRUCTURE

<b>LNBV</b>	LNB voltage control
<b>22kT</b>	22kHz tone control
<b>SHCM</b>	Short Circuit Mode
<b>LRST</b>	LNB reset control
<b>DISP</b>	Dot matrix display orientation control

##### 5.3.1.1. LNBV Control

<b>LNBV</b>	This control enables the user to set the LNB voltage control for Channel 1.
<b>CH1</b>	
OFF	Turns off DC voltage at RF IN port 1.
+13	Sets LNB port 1 voltage to +13Vdc.
+14	Sets LNB port 1 voltage to +14Vdc.
+18	Sets LNB port 1 voltage to +18Vdc.
+19	Sets LNB port 1 voltage to +19Vdc.

<b>LNBV</b>	This control enables the user to set the LNB voltage control for Channel 2.
<b>CH2</b>	
OFF	Turns off DC voltage at RF IN port 2.
+13	Sets LNB port 2 voltage to +13Vdc.
+14	Sets LNB port 2 voltage to +14Vdc.
+18	Sets LNB port 2 voltage to +18Vdc.
+19	Sets LNB port 2 voltage to +19Vdc.

##### 5.3.1.2. 22kHz Tone Control

<b>22kT</b>	This control enables the user to set the 22kHz Tone Control for Channel 1.
<b>CH1</b>	
ON	Turns ON 22kHz tone at RF IN port 1.
OFF	Turns OFF 22kHz tone at RF IN port 1.

<b>22kT</b>	This control enables the user to set the 22kHz Tone control for Channel 2.
<b>CH2</b>	
ON	Turns ON 22kHz tone at RF IN port 2.
OFF	Turns OFF 22kHz tone at RF IN port 2.

### 5.3.1.3. Short Circuit Mode Control

SHCM
CH1
DYNM
STC

This control enables the user to set the short circuit mode control for Channel 1.

Enables Dynamic short circuit mode on channel 1.  
Enables Static short circuit mode on channel 1.

SHCM
CH2
DYNM
STC

This control enables the user to set the short circuit mode control for Channel 2.

Enables Dynamic short circuit mode on channel 2.  
Enables Static short circuit mode on channel 2

### 5.3.1.4. LNB STATIC Mode Short Circuit/Overload Reset Control

LRST
CH1
RST

This control enables the user to reset the LNB voltage on Channel 1.

Resets LNB voltage on channel 1.

LRST
CH2
RST

This control enables the user to reset the LNB voltage on Channel 2.

Resets LNB voltage on channel 2.

### 5.3.1.5. Dot Matrix Display Control

DISP
HORZ
VERT

This control enables the user to set the orientation of the Dot Matrix Display.

Sets Dot matrix display to horizontal orientation.  
Sets Dot matrix display to vertical orientation.

### 5.3.2. STAT – (Status) MENU STRUCTURE

LNBV
LNBC
PWR
VER

LNB voltage monitoring

LNB current monitoring

RF power monitoring

Firmware version

### 5.3.2.1. LNB Voltage Monitoring

LNBV
CH1
0, +1 to +19, >+19

This control enables the user to monitor the LNB Voltage for Channel 1.  
Measurement of DC voltage at RF IN port 1. Values range from 0 to +19Vdc.

LNBV
CH2
0, +1 to +19, >+19

This control enables the user to monitor the LNB Voltage for Channel 2.  
Measurement of DC voltage at RF IN port 2. Values range from 0 to +19Vdc.

### 5.3.2.2. LNB Current Monitoring

LNBC
CH1
0-550

This control enables the user to monitor the LNB Current for Channel 1.  
Measurement of DC current at RF IN port 1. Values range from 0 to 550mA.

LNBC
CH2
0-550

This control enables the user to monitor the LNB Current for Channel 2.  
Measurement of DC current at RF IN port 2. Values range from 0 to 550mA.

### 5.3.2.3. RF Power Monitoring

PWR
CH1
-10 to -65

This control enables the user to monitor the RF Power for Channel 1.  
Measurement of RF power at RF IN port 1. Values range from -10 to -65dBm.

PWR
CH2
-10 to -65

This control enables the user to monitor the RF Power for Channel 2.  
Measurement of RF power at RF IN port 2. Values range from -10 to -65dBm.

### 5.3.2.4. VER Monitoring

VER
x.xx build y

This control enables the user to view the firmware version.



## **6. JUMPER CONTROLS**

### **6.1. SELECTING WHETHER LOCAL FAULTS WILL BE MONITORED BY THE GLOBAL FRAME STATUS**

The FRAME STATUS jumper, J3, determines whether local faults (as shown by the Local Fault indicator) will be connected to the 7700FR or 7800FR frame's global status bus.

**FRAME STATUS:** To monitor faults on this module with the frame status indicators (on the Power Supply FRAME STATUS LED's and on the Frame's Fault Tally output) install this jumper in the On position. (Default)

When this jumper is installed in the Off position local faults on this module will not be monitored.

### **6.2. CONFIGURING THE MODULE FOR FIRMWARE UPGRADES**

**UPGRADE:** The UPGRADE jumper J5 is used when firmware upgrades are being performed on the module. For normal operation it should be installed in the *RUN* position. See the *Upgrading Firmware* section of this manual for more information.

To upgrade the firmware in the module unit pull it out of the frame. Move the UPGRADE jumper into the *UPGRADE* position. Install the Upgrade cable provided (located in the vinyl pouch in the front of this manual) onto the SERIAL header (J7) at the card edge. Re-install the module into the frame. Run the upgrade as described in the *Upgrading Firmware* section of this manual binder. Once the upgrade is completed, remove the module from the frame, move the UPGRADE jumper into the *RUN* position, remove the upgrade cable and re-install the module. The module is now ready for normal operation.

## **7. VISTALINK<sup>®</sup> REMOTE MONITORING/CONTROL (7703/7803 ONLY)**

### **7.1. WHAT IS VISTALINK<sup>®</sup>?**

VistaLINK<sup>®</sup> is Evertz's remote monitoring and configuration platform which operates over an Ethernet network using Simple Network Management Protocol (SNMP). SNMP is a standard computer network protocol that enables different devices sharing the same network to communicate with each other. VistaLINK<sup>®</sup> provides centralized alarm management, which monitors, reports, and logs all incoming alarm events and dispatches alerts to all the VLPro Clients connected to the server. Card configuration through VistaLINK<sup>®</sup> PRO can be performed on an individual or multi-card basis using simple copy and paste routines, which reduces the time to configure each module separately. Finally, VistaLINK<sup>®</sup> enables the user to configure devices in the network from a central station and receive feedback that the configuration has been carried out.

There are 3 components of SNMP:

1. An SNMP manager, also known as a Network Management System (NMS), is a computer running special software that communicates with the devices in the network. Evertz VistaLINK<sup>®</sup> Pro Manager graphical user interface (GUI), third party or custom manager software may be used to monitor and control Evertz VistaLINK<sup>®</sup> enabled fiber optic products.
2. Managed devices (such as 7703LPS-2 and 7803LPS-2 cards), each with a unique address (OID), communicate with the NMS through an SNMP Agent. Evertz VistaLINK<sup>®</sup> enabled 7700 and 7800 series modules reside in the 3RU 7700/7800FR-C MultiFrame and communicate with the manager via the 7700FC VistaLINK<sup>®</sup> frame controller module, which serves as the Agent.
3. A virtual database, known as the Management Information Base (MIB), lists all the variables being monitored, which both the Manager and Agent understand. Please contact Evertz for further information about obtaining a copy of the MIB for interfacing to a third party Manager/NMS.

For more information on connecting and configuring the VistaLINK<sup>®</sup> network, see the 7700FC Frame Controller chapter.

## 7.2. VISTALINK® MONITORED PARAMETERS

The following parameters can be remotely monitored via the *VistaLINK®* interface.

Parameter	Description
LNB Current	LNB current on each port
RF Power	RF power on each port
LNB Voltage	LNB voltage on each port

**Table 7-1: VistaLINK® Monitored Parameters**

## 7.3. VISTALINK® CONTROLLED PARAMETERS

The following parameters can be remotely controlled via the *VistaLINK®* interface.

Parameter	Description
LNB Voltage	Set LNB voltage on each port
22kHz Tone generation	Enables 22kHz tone on each port
Short Circuit Mode	Enables dynamic or static short circuit mode
LNB current monitor upper threshold	Sets the upper threshold for LNB current
LNB current monitor lower threshold	Sets the lower threshold for LNB current
RF input power monitor upper threshold	Sets the upper threshold for RF input power
RF input power monitor lower threshold	Sets the lower threshold for RF input power

**Table 7-2: VistaLINK® Controlled Parameters**

## 7.4. VISTALINK® TRAPS

The following traps can be remotely enabled and monitored through *VistaLINK®* interface.

Trap	Description
LNB Short	Short detected on channel 1 or 2
LNB Current above Threshold	LNB current has risen above the threshold level on channel 1 or 2
LNB Current below Threshold	LNB current has risen above the threshold level on channel 1 or 2
RF power above Threshold	RF power has risen above the threshold level on channel 1 or 2
RF power below Threshold	LNB current has risen above the threshold level on channel 1 or 2

**Table 7-3: VistaLINK® Traps**

## **8. APPENDIX A**

### **8.1. HARDWARE OPTIONS**

This manual covers the following base hardware and all connector options:

- 7702LPS-2
- 7703LPS-2
- 7803LPS-2