

TABLE OF CONTENTS

1.	OVERVIEW	1
2.	INSTALLATION.....	3
3.	SPECIFICATIONS.....	5
3.1.	RF INPUT.....	5
3.2.	RF OUTPUTS	5
3.3.	ELECTRICAL.....	5
3.4.	PHYSICAL.....	5
4.	STATUS INDICATORS AND DISPLAY	6
4.1.	CARD EDGE LEDs	6
4.2.	DOT-MATRIX DISPLAY (7703 VERSIONS ONLY).....	6
4.2.1.	RF Threshold Levels	8
4.2.2.	Setting the Mode	8
4.2.3.	Setting the Gain.....	8
4.2.4.	AGC RF Output Target Level	9
4.2.5.	LNB Voltage Level.....	9
4.2.6.	22KHz Tone	9
4.2.7.	LNB Current Threshold Levels	9
4.2.8.	Default Card-Edge Display	9
4.2.9.	Setting the Display Orientation	10
4.2.10.	Displaying the RF Input Power	10
4.2.11.	Displaying the RF Threshold	10
4.2.12.	Displaying the Gain Mode Setting.....	10
4.2.13.	Displaying the Gain Setting	10
4.2.14.	Displaying the AGC RF Output Level	11
4.2.15.	Displaying the LNB Voltage Level.....	11
4.2.16.	22KHz Tone Status	11
4.2.17.	Displaying the LNB Current	11
4.2.18.	Displaying the LNB Current Threshold Level	11
4.2.19.	Displaying the Firmware Version	11
5.	JUMPERS AND USER ADJUSTMENTS.....	12
5.1.	SELECTING WHETHER LOCAL FAULTS WILL BE MONITORED BY THE GLOBAL FRAME STATUS.....	12
5.2.	CONFIGURING THE MODULE FOR FIRMWARE UPGRADES.....	13

- 5.3. SELECTING WHETHER THE MODULE WILL BE CONTROLLED FROM THE LOCAL CONTROLS OR THROUGH THE VISTALINK® INTERFACE - 7703 VERSIONS 13
- 5.4. FACTORY AND BDM JUMPERS 13
- 6. VISTALINK® REMOTE MONITORING/CONTROL - 7703 VERSIONS 14
 - 6.1. WHAT IS VISTALINK®? 14
 - 6.2. VISTALINK® MONITORED PARAMETERS 15
 - 6.3. VISTALINK® CONTROLLED PARAMETERS 15
 - 6.4. VISTALINK® TRAPS 16

Figures

- Figure 1-1: 7702(3)DA4A-RF Block Diagram 2
- Figure 1-2: 7702(3)DA8A-RF & 7702(3)DA16-RF Block Diagram 2
- Figure 2-1: 7702(3)DA4A-RF Rear Panels..... 3
- Figure 2-2: 7702(3)DA8A-RF & 7702(3)DA16-RF Rear Panels..... 4
- Figure 5-1: Jumper / LED Locations..... 12

Tables

- Table 4-1: Card Edge Menu Structure..... 8
- Table 6-1: VistaLINK® Monitored Parameters 15
- Table 6-2: VistaLINK® Controlled Parameters..... 15
- Table 6-3: VistaLINK® Traps 16

REVISION HISTORY

<u>REVISION</u>	<u>DESCRIPTION</u>	<u>DATE</u>
1.0	First Release	Nov 09
1.1	Added note in Installation section	Aug 13

Information contained in this manual is believed to be accurate and reliable. However, Evertz assumes no responsibility for the use thereof nor for the rights of third parties, which may be affected in any way by the use thereof. Any representations in this document concerning performance of Evertz products are for informational use only and are not warranties of future performance, either expressed or implied. The only warranty offered by Evertz in relation to this product is the Evertz standard limited warranty, stated in the sales contract or order confirmation form.

Although every attempt has been made to accurately describe the features, installation and operation of this product in this manual, no warranty is granted nor liability assumed in relation to any errors or omissions unless specifically undertaken in the Evertz sales contract or order confirmation. Information contained in this manual is periodically updated and changes will be incorporated into subsequent editions. If you encounter an error, please notify Evertz Customer Service department. Evertz reserves the right, without notice or liability, to make changes in equipment design or specifications.

This page left intentionally blank

1. OVERVIEW

The 7702(3)DA4A-RF, 7702(3)DA8A-RF, and 7702(3)DA16-RF 1 x 4, 1 x 8, and 1 x 16 Active Splitters provide amplification and distribution of RF signals from 40MHz to 3GHz. They handle any RF input modulation format and provide 4, 8, or 16 isolated outputs for further signal distribution. Typical applications include amplification and distribution of 950MHz-2150MHz L-Band and 70MHz-140MHz IF signals.

The 7702 card versions are simple, unity-gain (zero loss), single-input active splitters. The 7703 versions add adjustable gain/attenuation, monitoring of RF input power and card status and control of gain/attenuation is provided remotely via VistaLINK[®] capability on the 7703 versions. Optional LNB power is available at the input connector on the 7703 versions.

The 7702DA4A-RF & 7703DA4A-RF occupy one card slot and can be housed in a 1RU frame which holds up to 3 modules, a 3RU frame which holds up to 15 modules, a 350FR which holds up to 7 modules or a standalone enclosure which holds 1 module. The 7702DA8A-RF, 7702DA16-RF, 7703DA8A-RF & 7703DA16-RF occupy two card slots and can be housed in either a 1RU frame which holds up to 3 modules, a 3RU frame which holds up to 7 modules, a 350FR which holds up to 3 modules or a standalone enclosure which holds 1 module.

Features:

- Low noise amplification and distribution of RF signals from 40MHz to 3GHz
- Wideband frequency response for use with L-Band, 70/140MHz IF and off-air DTV signals
- Wide dynamic range (-10 to -60dBm)
- Adjustable output gain of -10dB to +20dB on 7703 versions
- AGC mode with adjustable target level on 7703 versions
- Fixed gain of 0dB on 7702 versions
- Protocol independent - handles all modulation formats
- Input RF signal strength and LNB current monitoring indication on 7703 versions
- Fully hot-swappable from front of frame
- Optional LNB power (@ +13 or +17V DC with built-in current limiting) and 22kHz (for LO control) on 7703 versions
- 7703-LNB versions include LNB current monitoring with adjustable alarm thresholds for early warning of LNB failure
- Comprehensive signal and card status monitoring via four digit card edge display or remotely through SNMP and VistaLINK[®] on 7703 versions.
- VistaLINK[®] capability is available when 7703 modules are used with the 3RU 7800FR frame and a 7700FC VistaLINK[®] Frame Controller module in slot 1 of the frame

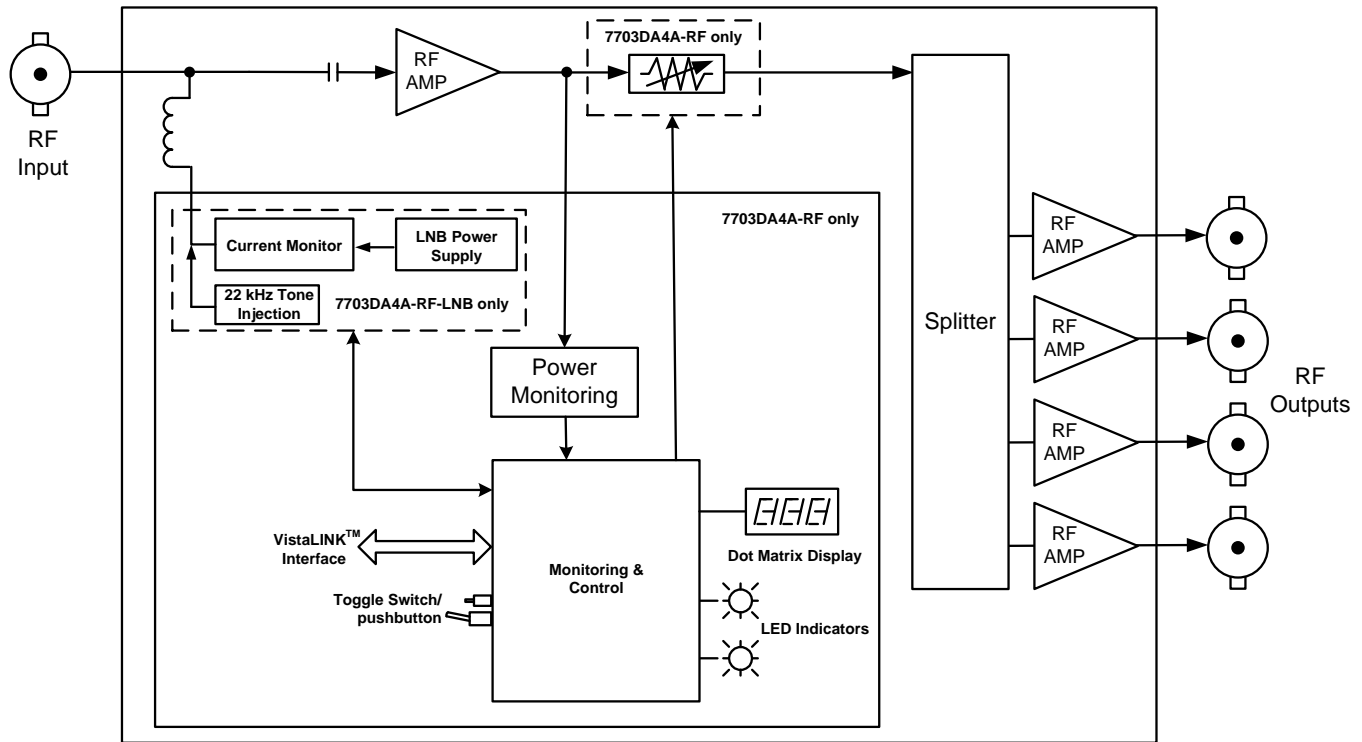

Figure 1-1: 7702(3)DA4A-RF Block Diagram

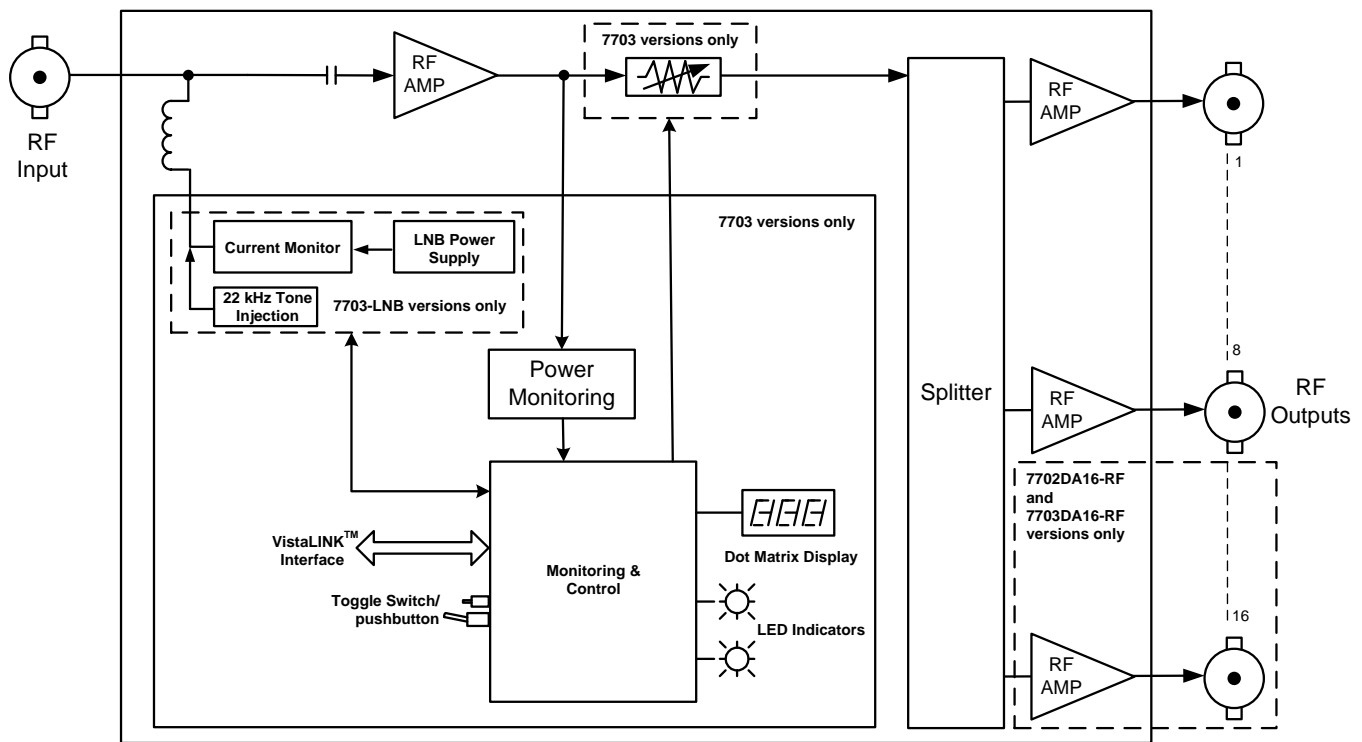

Figure 1-2: 7702(3)DA8A-RF & 7702(3)DA16-RF Block Diagram

2. INSTALLATION

The 7702/7703DA4A-RF active splitters come with a companion rear plate that has 5 BNC type 75Ω connectors (F type connectors are optional). The 7702/7703DA8A-RF active splitters come with a companion rear plate that has 9 BNC type 75Ω connectors (F type connectors are optional). The 7702/7703DA16-RF active splitters come with a companion rear plate that has 17 BNC type 75Ω connectors (F type connectors are optional). For information on mounting the rear plate and inserting the module into the frame see the 7700FR manual.

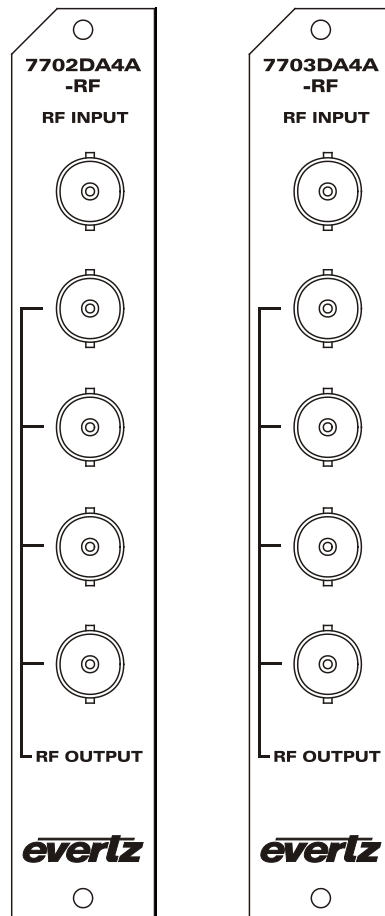

Figure 2-1: 7702(3)DA4A-RF Rear Panels

RF INPUT:

Input BNC type (F type optional) connector for satellite IF or L-Band RF signals. This signal can be an analog signal with frequency from 40MHz to 3GHz, with any modulation format.



The RF input is protected to the same degree as other professional RF devices, and will withstand a degree of ESD from handling, etc. Regardless, proper precautions should be taken during handling, such as the use of static bags and wrist straps. The input is not protected against lightning or other coupling of large energy spikes. If the installation is such that the RF input may be susceptible to spikes (e.g. direct connection to the antenna/LNB) then appropriate supplemental surge protection should be installed (e.g. Polyphaser).

RF OUTPUT: Four (DA4A) BNC (F type optional) connectors with amplified outputs for signal distribution. This signal can be an analog signal with frequency from 40MHz to 3GHz, with any modulation format.

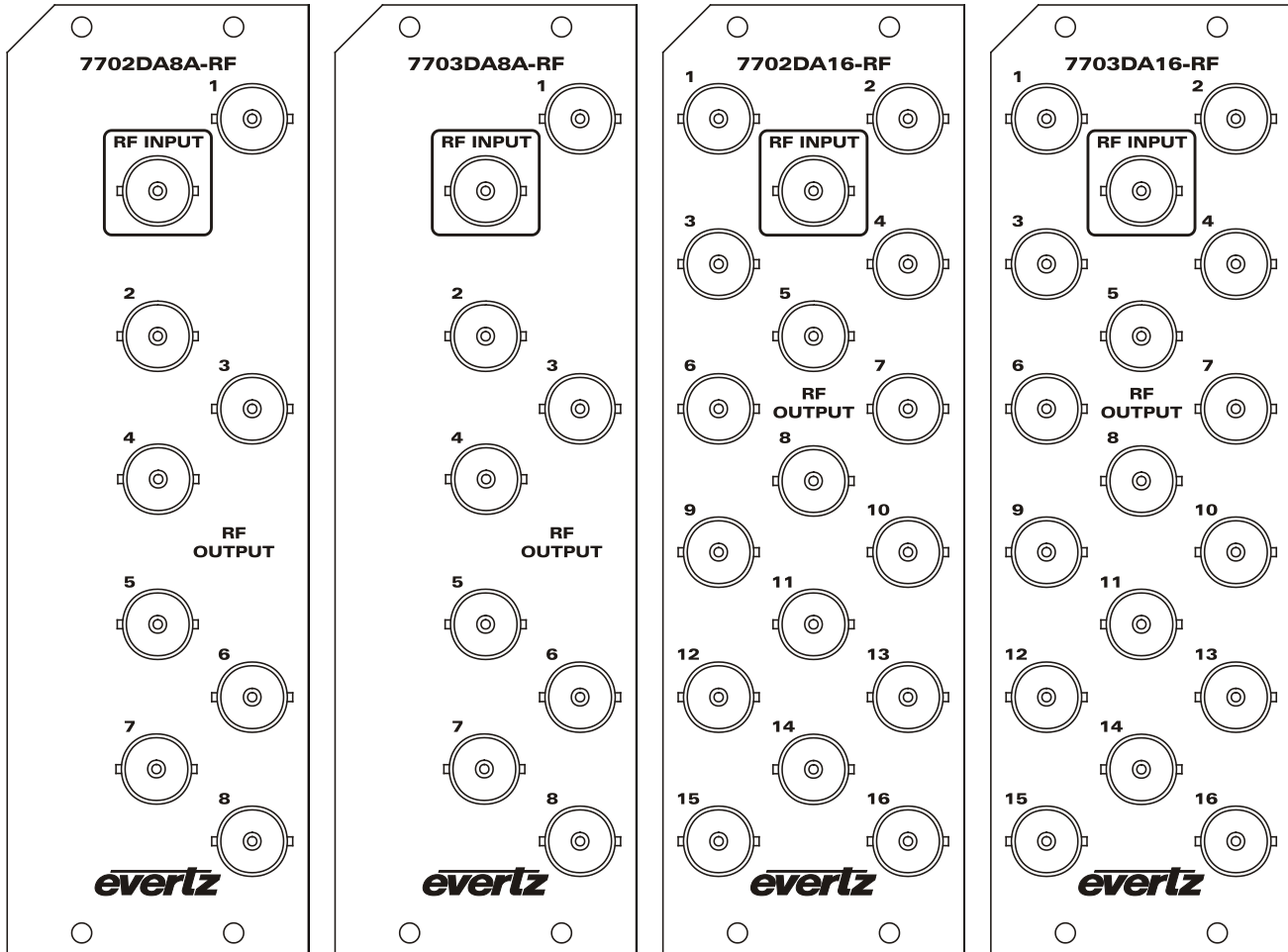

Figure 2-2: 7702(3)DA8A-RF & 7702(3)DA16-RF Rear Panels

RF INPUT: Input BNC type (F type optional) connector for satellite IF or L-Band RF signals. This signal can be an analog signal with frequency from 40MHz to 3GHz, with any modulation format.

RF OUTPUT: Eight (DA8A) or sixteen (DA16) BNC (F type optional) connectors with amplified outputs for signal distribution. This signal can be an analog signal with frequency from 40MHz to 3GHz, with any modulation format.

3. SPECIFICATIONS

3.1. RF INPUT

Connector:	1 BNC per IEC 61169-8 Annex A 2 (F-Type and SMA optional)
I/O Impedance:	75Ω (50Ω optional)
Return Loss:	> 13 dB
Input Frequency Range:	40MHz – 3GHz
Input Power Range:	-10 to -60 dBm
LNB Power:	+13/+17 VDC selectable
Current Limit:	400mA
LO Control:	22KHz on/off

3.2. RF OUTPUTS

Number of Outputs:	
7702(3)DA4A-RF:	4
7702(3)DA8A-RF:	8
7702(3)DA16-RF:	16
Connector:	BNC per IEC 61169-8 Annex A (F-Type and SMA optional)
I/O Impedance:	75Ω (50Ω optional)
Return Loss:	> 15 dB
Gain:	
7702 Versions:	0dB ± 2dB
7703 Versions:	-10dB to +20dB in 1/2 dB steps
Intermodulation Products:	< -50dBc (@ -10dBm input power and 0dB gain)
Frequency Response:	
7702(3)DA4A-RF:	40MHz - 200MHz ± 0.25dB 50MHz - 850MHz ± 0.25dB 850MHz - 2250MHz ± 0.5dB 40MHz - 3GHz ± 0.75dB
7702(3)DA8A-RF/ 7702(3)DA16-RF:	± 1.5dB
Isolation (Output to Output):	> 40 dB

3.3. ELECTRICAL

Voltage:	+ 12V DC
Power:	6 Watts (not including LNB power)

3.4. PHYSICAL

7700FR-C frame mounting:

Number of slots:	
7702(3)DA4A-RF:	1
7702(3)DA8A-RF/ DA16-RF:	2

4. STATUS INDICATORS AND DISPLAY

4.1. CARD EDGE LEDS

There are two large LEDs at the top of all the 7702(3)DA4A/8A/16-RF(-LNB) modules that indicate general module status:

MODULE OK: This Green LED will be On when the module is operating properly.

LOCAL FAULT: This Red LED will be On when there is a fault in the module power supply (e.g. blown fuse).

On the 7703 versions there are 5 small LEDs on the edge of the cards below the two large LEDs that indicate the RF input and output threshold alarms as well as AGC and LNB indications.

LED	Indication	Function
RF INPUT	HIGH	This Red LED will be On when there is a RF input signal that is above the upper threshold.
	OK	This Green LED will be On when there is a RF input signal that is within the lower and upper thresholds.
	LOW	This Yellow LED will be ON when there is a RF input signal that is below the lower threshold.

AGC	RED	AGC is on but unable to maintain output power setting.
	GREEN	AGC is on and can maintain output power setting.
	OFF	AGC is off (manual mode).

LNB	RED	LNB Short (fault).
	GREEN	LNB OK (no short).
	OFF	LNB OFF.

4.2. DOT-MATRIX DISPLAY (7703 VERSIONS ONLY)

Additional signal and status monitoring and control over the card's parameters are provided via the 4-digit alphanumeric display located on the card edge. To select one of two menu display modes, press the toggle switch. To go to the sub-menu press the pushbutton once and press the toggle switch to select the sub-menu. When in a particular display mode, press the pushbutton to display the value and use the toggle switch to change values (if applicable) and to see what status is being displayed for the particular menu item. Table 4-1 provides a quick reference to the display menu structure.

Level 1	Level 2	Level 3	Level 4	Level 5	
DEFD Selection	BACK				
	CTRL	BACK			
		RFTH	LWR	0 to -60 dBm Default -60 dBm	
			UPPR	0 to -60 dBm Default 0 dBm	
		MODE	AGC		
			MAN (default)		
		GAIN (visible in manual mode only)	-10 to 20dB default: 0dB		
		OUTL (visible in AGC mode only)	0 to -50dBm default: -20dBm		
		LNBV (visible only for -LNB versions)	17V		
			13V		
			OFF (default)		
		22KT (visible only for -LNB versions)	ON		
			OFF (default, also can only be off if LNBV is off)		
		LNTH (visible only for -LNB versions)	LWR	0 to 500mA default = 0	
			UPPR	0 to 500mA default = 500	
		DEFD	Fault status(default)		
			PWR		
			MODE		
	GAIN				
	OUTL				
	LNBV (-LNB only)				
	22KT (-LNB only)				
	LNBC (-LNB only)				
	DISP	HORZ			
		VERT (default)			
	STAT	BACK			
		PWR	0 to -60dBm		
		RFTH	LWR	0 to -60 dBm	
			UPPR	0 to -60 dBm	
		MODE	AGC		
			MAN		
		GAIN (visible in manual mode only)	-10 to 20dB		
OUTL (visible in AGC mode only)	0 to -50dBm				

		LNBV (visible only for - LNB versions)	17V	
			13V	
			OFF	
		22KT (visible only for - LNB versions)	ON	
			OFF	
		LNBC (visible only for - LNB versions)	0 to 500mA	
		LNTH (visible only for - LNB versions)	LWR	0 to 500mA
			UPPR	0 to 500mA
		VER	Firmware version	

Table 4-1: Card Edge Menu Structure

4.2.1. RF Threshold Levels

The input RF level thresholds can be set by entering into the *RFTH* menu. From here, the user can select either the *LWR* or *UPPR* option. Toggling the switch will move through a range of values in 1dBm increments. Hitting the pushbutton will select the displayed value.

CTRL	<i>LWR</i>	Sets the lower RF threshold level. Default of -60dBm.
RFTH	<i>UPPR</i>	Sets the upper RF threshold level. Default of 0 dBm.
LWR / UPPR	<i>0 to -60dBm</i>	RF threshold range (in dBm units).

4.2.2. Setting the Mode

To adjust the gain mode, enter the *Mode* menu setting. In AGC mode, the card will automatically apply up to 20dB of gain or 10dB of attenuation to the input signal in order to maintain the AGC target output level (see section 4.2.4 for information on setting this level). In manual gain control mode, the output level will be offset from the input level by the amount of applied gain/attenuation (see section 4.2.3 for information on setting the gain).

CTRL	AGC	Enables Automatic Gain Control mode.
MODE	MAN	Enables manual control. (default)
AGC		
MAN		

4.2.3. Setting the Gain

CTRL		Sets the fixed amount of applied gain. Visible in manual mode only.
GAIN	<i>-10 to 20 dB</i>	RF Gain range (in dB units). Default of 0 dB.

4.2.4. AGC RF Output Target Level

CTRL
OUTL
0 to -50dBm

Sets the RF output power target in AGC mode. Visible in AGC mode only.

0 to -50dBm RF output power range. Default of -20dBm.

4.2.5. LNB Voltage Level

CTRL
LNBV
18V
13V
OFF

Sets the LNB output voltage. Visible on -LNB versions only.

18V Sets the LNB output voltage to 18 volts.
13V Sets the LNB output voltage to 13 volts.
OFF Disables the LNB output voltage.

4.2.6. 22KHz Tone

CTRL
22KT
ON
OFF

Enables the 22KHz tone for LNB LO control on the RF Input. Visible on -LNB versions only. The default setting is OFF.

ON Enables the 22KHz tone.
OFF Disables the 22KHz tone.

4.2.7. LNB Current Threshold Levels

CTRL
LNTH
LWR / UPPR
0 to 500mA

LWR Sets the low LNB current alarm threshold. Default of 0.
UPPR Sets the high LNB current alarm threshold. Default of 500.

0 to 500mA RF threshold range.

4.2.8. Default Card-Edge Display

This allows the user to select which operating condition will be the top-level item on the dot-matrix display. The default is NORM, which displays "OK" as long as local power to the board is available. The table below provides a list of alternate parameters.

CTRL
DEFD
NORM
PWR
MODE
GAIN
OUTL
LNBV
22KT
LNBC

NORM Local power status
PWR Measured RF Input power
MODE Gain mode
GAIN Gain setting (manual mode only)
OUTL AGC output level setting (AGC mode only)
LNBV LNB voltage setting
22KT 22kHz tone setting
LNBC Measured LNB current

4.2.9. Setting the Display Orientation

The *DISP* option allows the user to set a horizontal or vertical orientation for the card edge display. To set the display orientation, select the *CTRL* menu item in the first menu level, then use the toggle switch to show the *DISP* menu selection and use the pushbutton to select it. Use the toggle switch to change between *HORZ* and *VERT*. Press the push button to make your selection.

<i>CTRL</i>		<i>HORZ</i>	Horizontal display used when the module is housed in the one-rack unit 7701FR frame or the stand-alone enclosure.
<i>DISP</i>		<i>VERT</i>	
<i>HORZ</i>			
<i>VERT</i>			

4.2.10. Displaying the RF Input Power

The 7703DA4A/8A/16-RF detects the RF input power level and displays this on the four-digit card edge display.

<i>STAT</i>		Displays the RF input power level.	
<i>PWR</i>		<i>0 to -60dBm</i>	RF input power range (in dBm units).
<i>0 to -60dBm</i>			

4.2.11. Displaying the RF Threshold

<i>STAT</i>		<i>LWR</i>	Indicates the low RF alarm threshold level.
<i>RFTH</i>		<i>UPPR</i>	Indicates the high RF alarm threshold level.
<i>LWR / UPPR</i>		<i>0 to -60dBm</i>	RF threshold range (in dBm units).
<i>0 to -60dBm</i>			

4.2.12. Displaying the Gain Mode Setting

<i>STAT</i>		Indicates whether the gain mode setting is in AGC or manual.	
<i>MODE</i>			
<i>AGC</i>			
<i>MAN</i>			

4.2.13. Displaying the Gain Setting

<i>STAT</i>		Indicates the amount of gain applied to the input signal.	
<i>GAIN</i>		<i>-10 to 20 dB</i>	RF Gain range (in dB units).
<i>-10 to 20 dB</i>			

4.2.14. Displaying the AGC RF Output Level

CTRL	Indicates the RF output power target in AGC mode. Visible in AGC mode only.
OUTL	
0 to -50dBm	

0 to -50dBm RF output power range. Default of -20dBm.

4.2.15. Displaying the LNB Voltage Level

STAT	Indicates the LNB output voltage.	
LNBV		
18V		18V Sets the LNB output voltage to 18 volts.
13V		13V Sets the LNB output voltage to 13 volts.
OFF	OFF Disables the LNB output voltage.	

4.2.16. 22KHz Tone Status

CTRL	Indicates whether the 22KHz tone on LNB output is enabled or disabled.
22KT	
ON	
OFF	OFF 22KHz tone is disabled.

4.2.17. Displaying the LNB Current

STAT	Indicates the LNB current. Visible for -LNB versions only.
LNBC	
0 to 500A	

4.2.18. Displaying the LNB Current Threshold Level

STAT	LWR Indicates the lower RF threshold level. UPPR Indicates the upper RF threshold level.
LNTH	
LWR / UPPR	0 to 500A RF threshold range.
0 to 500A	

4.2.19. Displaying the Firmware Version

The *VER* display shows the firmware version and build number of the 7703DA4A/8A/16-RF firmware. The message will scroll across the display.

For example: *VER 1.0 BLD 067*

5. JUMPERS AND USER ADJUSTMENTS

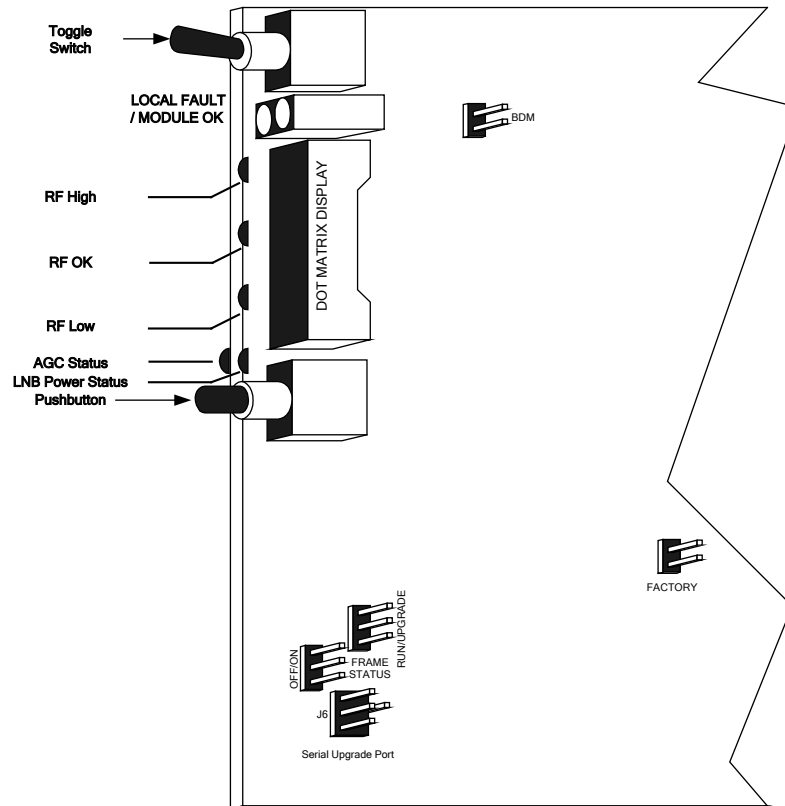

Figure 5-1: Jumper / LED Locations

5.1. SELECTING WHETHER LOCAL FAULTS WILL BE MONITORED BY THE GLOBAL FRAME STATUS

The FRAME STATUS jumper J9, located at the front of the module determines whether local faults (as shown by the Local Fault indicator) will be connected to the 7700FR frame's global status bus.

FRAME STATUS: To monitor faults on this module with the frame status indicators (on the PS FRAME STATUS LED's and on the Frame's Fault Tally output) install this jumper in the On position. On Rev 1 and A boards install the jumper. (default)

When this jumper is installed in the Off position local faults on this module will not be monitored.

5.2. CONFIGURING THE MODULE FOR FIRMWARE UPGRADES

UPGRADE: The UPGRADE jumper J12 is used when firmware upgrades are being done to the module. For normal operation it should be installed in the *RUN* position. See the *Upgrading Firmware* chapter in the front of the manual binder for more information.

To upgrade the firmware in the module unit pull it out of the frame. Move the UPGRADE jumper into the *UPGRADE* position. Install the Upgrade cable provided (located in the vinyl pouch in the front of this manual) onto the SERIAL header J14 at the card edge. Re-install the module into the frame. Run the upgrade as described in the *Upgrading Firmware* chapter of this manual. Once the upgrade is completed, remove the module from the frame, move the UPGRADE jumper into the *RUN* position, remove the upgrade cable and re-install the module. The module is now ready for normal operation.

5.3. SELECTING WHETHER THE MODULE WILL BE CONTROLLED FROM THE LOCAL CONTROLS OR THROUGH THE VISTALINK[®] INTERFACE - 7703 VERSIONS

The MASTER/SLAVE jumper J11 selects whether the module will be controlled from the local user controls or through the VistaLINK[®] interface.

MASTER/SLAVE: When this jumper is installed in the MASTER position, the card functions are controlled through the local controls.

When this jumper is installed in the SLAVE position, the card functions are controlled through the VistaLINK[®] interface.

5.4. FACTORY AND BDM JUMPERS

When shipped from the Evertz facility, the FACTORY and BDM jumpers will not be installed. These jumpers ***should not*** be installed for any reason. If jumpers are on these positions they should be removed.

6. VISTALINK® REMOTE MONITORING/CONTROL - 7703 VERSIONS

6.1. WHAT IS VISTALINK®?

VistaLINK® is Evertz's remote monitoring and configuration platform which operates over an Ethernet network using Simple Network Management Protocol (SNMP). SNMP is a standard computer network protocol that enables different devices sharing the same network to communicate with each other. VistaLINK® provides centralized alarm management, which monitors, reports, and logs all incoming alarm events and dispatches alerts to all the VLPro Clients connected to the server. Card configuration through VistaLINK® PRO can be performed on an individual or multi-card basis using simple copy and paste routines, which reduces the time to configure each module separately. Finally, VistaLINK® enables the user to configure devices in the network from a central station and receive feedback that the configuration has been carried out.

There are 3 components of SNMP:

1. An SNMP manager, also known as a Network Management System (NMS), is a computer running special software that communicates with the devices in the network. Evertz VistaLINK® Pro Manager graphical user interface (GUI), third party or custom manager software may be used to monitor and control Evertz VistaLINK® enabled fiber optic products.
2. Managed devices (such as 7703DA4A/8A/16-RF cards), each with a unique address (OID), communicate with the NMS through an SNMP Agent. Evertz VistaLINK® enabled 7700 series modules reside in the 3RU 7700FR-C MultiFrame and communicate with the manager via the 7700FC VistaLINK® frame controller module, which serves as the Agent.
3. A virtual database, known as the Management Information Base (MIB), lists all the variables being monitored, which both the Manager and Agent understand. Please contact Evertz for further information about obtaining a copy of the MIB for interfacing to a third party Manager/NMS.

For more information on connecting and configuring the VistaLINK® network, see the 7700FC Frame Controller chapter.

6.2. VISTALINK® MONITORED PARAMETERS

The following parameters can be remotely monitored through the VistaLINK® interface.

Parameter	Description
RF Input Power	A range of values describing received RF power at the input.
RF Input Power Threshold	A range of values indicating the lower/upper RF threshold levels.
Gain Mode	Indicates RF mode setting.
RF Gain	A range of values indicating RF gain setting.
RF Output Level	A range of values indicating RF power target setting.
LNB Voltage Level	Indicates LNB voltage levels.
22KHz Tone	Indicates the on/off status of the 22KHz tone.
LNB Current	A range of values indicating the LNB current.
LNB Current Threshold	A range of values indicating the LNB current threshold.
Firmware Version	Displays firmware version number.

Table 6-1: VistaLINK® Monitored Parameters

6.3. VISTALINK® CONTROLLED PARAMETERS

The following parameter can be remotely controlled through the VistaLINK® interface.

Parameter	Description
RF Threshold	Sets the value of the input upper/lower thresholds.
Mode	Set the mode level.
Gain	Set the gain level.
OUTL	Sets the RF power target level.
LNbv	Sets the LNB voltage level.
22KT	Enables the 22KHz tone.
LNTH	Sets the LNB threshold level.
DISP	Sets the horizontal/vertical display orientation.

Table 6-2: VistaLINK® Controlled Parameters

6.4. VISTALINK[®] TRAPS

The following traps can be controlled through the VistaLINK[®] interface. Each trap will indicate a fault condition when its value is True.

Trap	Description
RF Input Power High	Input power is above the threshold.
RF Input Power Low	Input power is below the threshold.
AGC Out of Range	AGC is out of range.
LNB Short	Short on LNB DC supply (for -L version only).
LNB Current High	LNB current is above the threshold.
LNB Current Low	LNB current is below the threshold.

Table 6-3: VistaLINK[®] Traps