TABLE OF CONTENTS

1.	OVERVIEW.....	1
2.	INSTALLATION.....	3
3.	SPECIFICATIONS.....	4
3.1.	SERIAL VIDEO INPUT	4
3.2.	SERIAL VIDEO OUTPUTS.....	4
3.3.	ANALOG VIDEO OUTPUTS	4
3.4.	ELECTRICAL	4
3.5.	PHYSICAL.....	4
4.	STATUS LEADS.....	5
5.	JUMPERS AND USER ADJUSTMENTS.....	6
5.1.	SELECTING WHETHER LOCAL FAULTS WILL BE MONITORED BY THE GLOBAL FRAME STATUS.....	7
5.2.	SELECTING THE NTSC SETUP PEDESTAL	7
5.3.	SELECTING THE FUNCTION OF OUTPUTS.....	7

Figures

Figure 1-1:	500VMDA Block Diagram – PCB Rev A.....	1
Figure 1-2:	500VMDA Block Diagram – PCB Rev B.....	2
Figure 2-1:	500VMDA Rear Panel Overlay	3
Figure 5-1:	LED and Jumper Locations for PCB Rev A.....	6
Figure 5-2:	LED and Jumper Locations for PCB Rev B.....	6

REVISION HISTORY

<u>REVISION</u>	<u>DESCRIPTION</u>	<u>DATE</u>
1.0	Original Version	Nov 02
1.1	Update for Rev B boards with 9 configurable outputs.	Feb 03
1.2	Additional updates for PCB Rev B boards with 9 configurable outputs.	Dec 06

Information contained in this manual is believed to be accurate and reliable. However, Evertz assumes no responsibility for the use thereof nor for the rights of third parties, which may be effected in any way by the use thereof. Any representations in this document concerning performance of Evertz products are for informational use only and are not warranties of future performance, either express or implied. The only warranty offered by Evertz in relation to this product is the Evertz standard limited warranty, stated in the sales contract or order confirmation form.

Although every attempt has been made to accurately describe the features, installation and operation of this product in this manual, no warranty is granted nor liability assumed in relation to any errors or omissions unless specifically undertaken in the Evertz sales contract or order confirmation. Information contained in this manual is periodically updated and changes will be incorporated into subsequent editions. If you encounter an error, please notify Evertz Customer Service department. Evertz reserves the right, without notice or liability, to make changes in equipment design or specifications.

1. OVERVIEW

The Evertz 500VMDA Reclocking Distribution Amplifier provides inexpensive distribution and monitoring of your SMPTE 259M serial digital video signal at rates of 270 Mb/s. The DA features an auto-equalized input with nine outputs that can be selected as either reclocked SD-SDI or composite analog. (Early versions of the DA feature an auto-equalized input with five reclocked SD-SDI outputs and four outputs that can be selected as either SD-SDI or composite analog.)

The 500VMDA is housed in the 500FR **exponent** Frame that will hold up to 16 modules.

Features:

- Supports SMPTE 259M (270 Mb/s) video
- 9 outputs selectable as SD-SDI or composite analog (NTSC/PAL)
- Selectable NTSC pedestal on/off
- Fully hot-swappable from front of frame with no BNC disconnect required
- Independent isolated output drivers to ensure no cross channel loading effects (i.e. no need to terminate unused outputs)
- Video present, cable length warning, and video standard LEDs
- Tally output on Frame Status bus upon loss of input signal

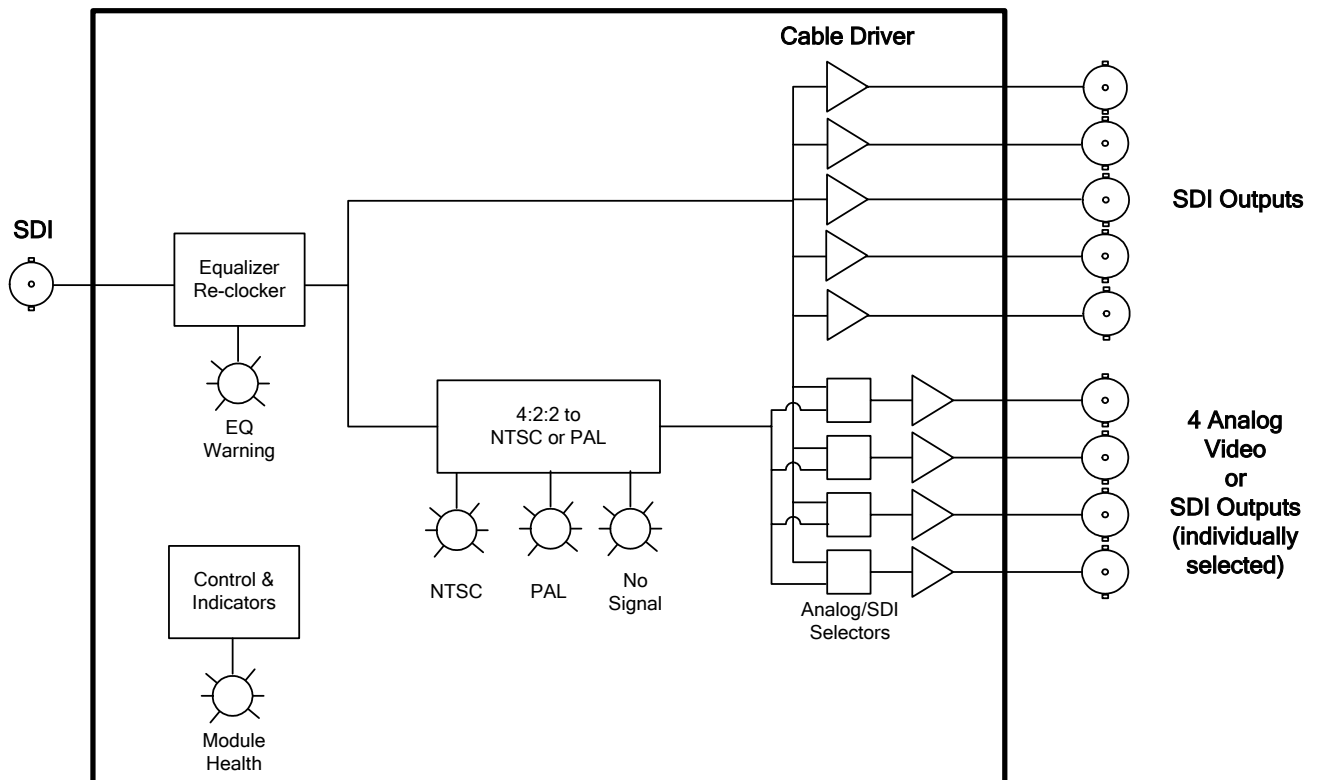

Figure 1-1: 500VMDA Block Diagram – PCB Rev A

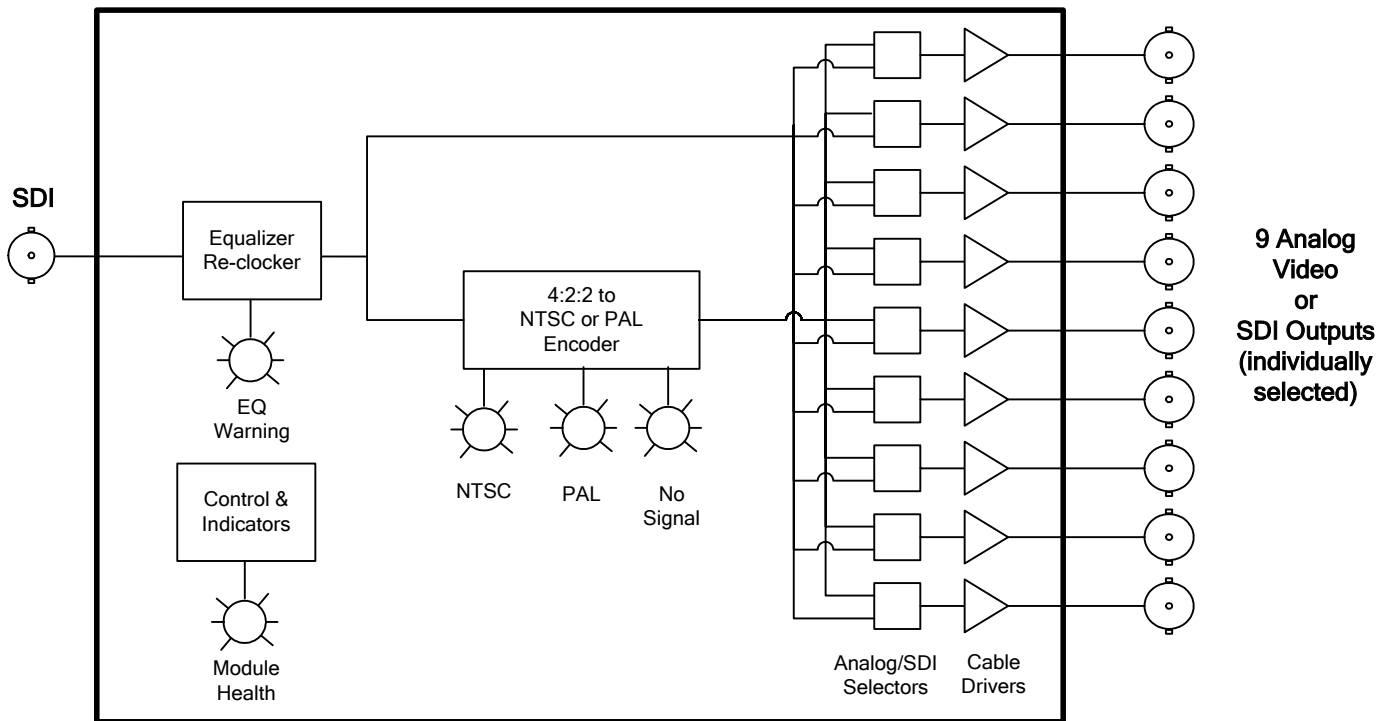

Figure 1-2: 500VMDA Block Diagram – PCB Rev B

2. INSTALLATION

The 500VMDA comes with a companion rear panel overlay that can be placed over the rear panel BNC connectors to identify their function. For information on inserting the module into the frame see section 3 of the 500FR chapter.

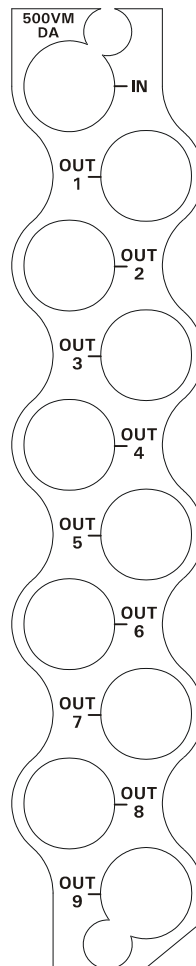

Figure 2-1: 500VMDA Rear Panel Overlay

IN Input BNC connector for 10-bit serial digital video signals compatible with the SMPTE 259M-C standard.

OUT 1 to 9 These BNC connectors can be individually configured either as reclocked serial component video outputs, compatible with the SMPTE 259M-C standard, or as composite analog (NTSC/PAL) video outputs. On Rev A boards, outputs 1 to 5 are reclocked SD-SDI only and outputs 6 to 9 can be configured. See section 5.3 for information on selecting the output type.

3. SPECIFICATIONS

3.1. SERIAL VIDEO INPUT

Standards: SMPTE 259M-C (270 Mb/s) 525 or 625 line.
Connector: 1 BNC per IEC 169-8
Equalization: Automatic to 430m @ 270 Mb/s with Belden 1694A or equivalent cable (340m with HD-SDI modules within 500 FR frame)
Return Loss: > 15 dB up to 270 Mb/s

3.2. SERIAL VIDEO OUTPUTS

Number of Outputs: Up to 9 reclocked outputs (jumper selectable)
Connector: BNC per IEC 169-8
Signal Level: 800mV nominal
DC Offset: 0V \pm 0.5V
Rise and Fall Time: 470ps nominal
Overshoot: < 10% of amplitude
Return Loss: > 15 dB up to 270 Mb/s
Wide Band Jitter: < 0.2 UI

3.3. ANALOG VIDEO OUTPUTS

Number of Outputs: Up to 9 (jumper selectable)
Standards: NTSC, SMPTE 170M if input is 525i/59.94
PAL-B ITY 624-4 if input is 625i/50
Connectors: BNC per IEC 169-8
Signal Level: 1 V p-p nominal
DC Offset: 0V \pm 0.1V
Return Loss: > 35 dB up to 5 MHz

3.4. ELECTRICAL

Voltage: + 12VDC
Power: 6 Watts
EMI/RFI: Complies with FCC Part 15 Class A, EU EMC Directive

3.5. PHYSICAL

Number of slots: 1

4. STATUS LEDS

The 500VMDA has six LED Status indicators on the front card edge to show operational status of the card at a glance. Figure 5-1 shows the location of the LEDs.

Two large LEDs on the front of the board indicate the general health of the module:

LOCAL FAULT: This Red LED indicates poor module health and will be On during the absence of a valid input signal or if a local input power fault exists (i.e.: a blown fuse). The LOCAL FAULT indication can also be reported to the frame through the FRAME STATUS jumper.

MODULE OK: This Green LED indicates good module health. It will be On when a valid input signal is present, and board power is good.

There are four small LEDs that indicate the status of the equalizer and reclocker:

LOCK: This Green LED will be On when there is a valid signal present at the module input.

CABLE LENGTH WARNING: This Yellow LED will be On when the cable equalizer detects that the cable length is greater than a preset threshold (factory set for 325 meters of Belden 1694A or equivalent cable).

NTSC: This Green LED will be On when there is a valid 525 line SD-SDI signal present at the module input.

PAL: This Green LED will be On when there is a valid 625 line SD-SDI signal present at the module input.

5. JUMPERS AND USER ADJUSTMENTS



Figure 5-1: LED and Jumper Locations for PCB Rev A



Figure 5-2: LED and Jumper Locations for PCB Rev B

5.1. SELECTING WHETHER LOCAL FAULTS WILL BE MONITORED BY THE GLOBAL FRAME STATUS

The FRAME STATUS jumper J1, located at the front of the module, determines whether local faults (as shown by the Local Fault indicator) will be connected to the 500FR frame's global status bus.

FRAME STATUS: To monitor faults on this module with the frame status indicators (on the power supply's FRAME STATUS LED's and on the Frame's Fault Tally output) install this jumper in the On position.

When this jumper is installed in the Off position local faults on this module will not be monitored.

5.2. SELECTING THE NTSC SETUP PEDESTAL

SETUP PEDESTAL: Jumper J11 is used to select whether the 500VMDA will add a 7.5 IRE Setup pedestal to the NTSC outputs. The setup pedestal should not be present when operating in Japan.

To set the module to add the Setup pedestal, install the jumper in the On position.

To set the module to not add the Setup pedestal, install the jumper in the Off position.



The card must be power-cycled after changing this jumper.

5.3. SELECTING THE FUNCTION OF OUTPUTS

OUTPUT SELECT: Four jumpers J7 to J10 are used to select whether outputs 6 to 9 will output reclocked SD-SDI video or composite analog (NTSC/PAL) video on PCB Rev A only.

Jumpers J12 to J16 are used to select whether outputs 1 to 5 will output reclocked SD-SDI video or composite analog (NTSC/PAL) video on PCB Rev B.

To select SD-SDI on the output, install the respective jumper in the SD-SDI position (closest to the bottom edge of the card). Refer to Figure 5-1 and Figure 5-2.

To select composite analog on the output, install the respective jumper in the NTSC/PAL position (toward the top card edge). Refer to Figure 5-1 and Figure 5-2.



The VBI is blanked on the composite outputs.

This page left intentionally blank