

3505FR Series Fiber Optic SFP Frame Installation and Operating Manual

© Copyright 2014 - 2015

EVERTZ MICROSYSTEMS LTD.

5288 John Lucas Drive,
Burlington, Ontario,
Canada L7L 5Z9

Phone: 905-335-3700

Sales: sales@evertz.com Fax: 905-335-3573

Tech Support: service@evertz.com Fax: 905-335-7571

Web Page: <http://www.evertz.com>



Version 1.2, February 2015

The material contained in this manual consists of information that is the property of Evertz Microsystems and is intended solely for the use of purchasers of the 3505FR Series. Evertz Microsystems expressly prohibits the use of this manual for any purpose other than the operation of the device. Due to on going research and development, features and specifications in this manual are subject to change without notice.

All rights reserved. No part of this publication may be reproduced without the express written permission of Evertz Microsystems Ltd. Copies of this manual can be ordered from your Evertz dealer or from Evertz Microsystems.

This page left intentionally blank

IMPORTANT SAFETY INSTRUCTIONS

	The lightning flash with arrowhead symbol within an equilateral triangle is intended to alert the user to the presence of un-insulated, dangerous voltage within the product's enclosure that may be of sufficient magnitude to constitute a risk of electric shock to persons.
	The exclamation point within an equilateral triangle is intended to alert the user to the presence of important operating and maintenance (i.e.: servicing) instructions in the literature accompanying the product.

- Read these instructions.
- Keep these instructions.
- Heed all warnings.
- Follow all instructions.
- Don't use this apparatus near water.
- Clean only with a dry cloth.
- Don't block any ventilation openings.
- Install in accordance with the manufacturer's instructions.
- Don't install near any heat sources such as radiators, heat registers, stoves, or other apparatuses (including amplifiers) that produce heat.
- Don't defeat the safety purpose of the polarized or grounding-type plug. A polarized plug has two blades with one wider than other. A grounding-type plug has two blades and a third grounding prong. The wide blade or third prong is provided for your safety. If the plug provided does not fit into your outlet, consult an electrician to replace the obsolete outlet.
- Protect the power cord from being walked on or pinched, particularly at plugs, convenience receptacles, and the point where they exit from the apparatus.
- Only use attachments/accessories specified by the manufacturer
- Unplug this apparatus during lightning storms, or when unused for long periods of time.
- Refer all servicing to qualified service personnel. Servicing is required when the apparatus has been damaged in any way, such as damage to the power-supply cord or plug, contact with liquid (or any object small enough to enter the apparatus), exposure to rain or moisture, drop damage, or upon experiencing any abnormal operation.

WARNING:

TO REDUCE THE RISK OF FIRE OR ELECTRIC SHOCK, **DO NOT** EXPOSE THIS APPARATUS TO RAIN OR MOISTURE

WARNING:

DO NOT EXPOSE THIS EQUIPMENT TO DRIPPING OR SPLASHING AND ENSURE THAT NO OBJECTS FILLED WITH LIQUIDS, SUCH AS VASES, ARE PLACED ON THE EQUIPMENT

WARNING:

TO COMPLETELY DISCONNECT THIS EQUIPMENT FROM THE AC MAINS, DISCONNECT THE POWER SUPPLY CORD PLUG FROM THE AC RECEPTACLE

WARNING:

THE MAINS PLUG OF THE POWER SUPPLY CORD SHALL REMAIN READILY OPERABLE

FIBER OPTIC DEVICES

Some modules in this product may have fiber optic outputs. The following safety information applies to the optical outputs of these modules. Consult individual chapters for specific safety information for handling fiber optics.

WARNING



CAUTION – CLASS 1 VISIBLE & INVISIBLE LASER RADIATION WHEN OPEN DO NOT VIEW DIRECTLY OR WITH OPTICAL INSTRUMENTS.

ELECTROSTATIC SENSITIVE DEVICES



The hand symbol within an equilateral triangle is intended to alert the user to instructions related to precautions for handling electrostatic-sensitive devices. See “Electro Static Discharge (ESD) Precautions” section for further details.

INFORMATION TO USERS IN EUROPE

NOTE

This equipment with the CE marking complies with both the EMC Directive (2004/108/EC) and the Low Voltage Directive (2006/95/EC) issued by the Commission of the European Community.

Compliance with these directives implies conformity to the following European standards:

- EN60065 Product Safety
- EN55103-1 Electromagnetic Interference Class A (Emission)
- EN55103-2 Electromagnetic Susceptibility (Immunity)

This equipment has been tested and found to comply with the limits for a Class A digital device, pursuant to the European Union EMC directive. These limits are designed to provide reasonable protection against harmful interference when the equipment is operated in a commercial environment. This equipment generates, uses, and can radiate radio frequency energy and, if not installed and used in accordance with the instruction manual, may cause harmful interference to radio communications. Operation of this equipment in a residential area is likely to cause harmful interference in which case the user will be required to correct the interference at his own expense.

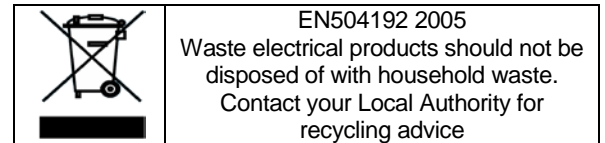
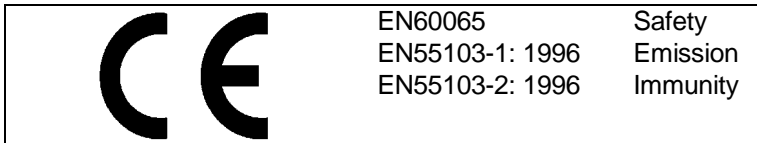

INFORMATION TO USERS IN THE U.S.A.

NOTE

FCC CLASS A DIGITAL DEVICE OR PERIPHERAL

This equipment has been tested and found to comply with the limits for a Class A digital device, pursuant to Part 15 of the FCC Rules. These limits are designed to provide reasonable protection against harmful interference when the equipment is operated in a commercial environment. This equipment generates, uses, and can radiate radio frequency energy and, if not installed and used in accordance with the instruction manual, may cause harmful interference to radio communications. Operation of this equipment in a residential area is likely to cause harmful interference in which case the user will be required to correct the interference at his own expense.

WARNING

Changes or modifications not expressly approved by Evertz Microsystems Ltd. could void the user's authority to operate the equipment. Use of unshielded plugs or cables may cause radiation interference. Properly shielded interface cables with the shield connected to the chassis ground of the device must be used

Evertz Microsystems Ltd



For Commercial Use

Tested to comply
with FCC
Standards

This device complies with part 15 of the FCC Rules. Operation is subject to the following two conditions:

This device may cause harmful interference, and this device must accept any interference received, including interference that may cause undesired operation.

REVISION HISTORY

<u>REVISION</u>	<u>DESCRIPTION</u>	<u>DATE</u>
1.0	First Release	Feb 2014
1.1	Update throughout	May 2014
1.2	Added Connector Mapping Tables	Feb 2015

Information contained in this manual is believed to be accurate and reliable. However, Evertz assumes no responsibility for the use thereof, nor for the rights of third parties, which may be affected in any way by the use thereof. Any representations in this document concerning performance of Evertz products are for informational use only and are not warranties of future performance, either expressed or implied. The only warranty offered by Evertz in relation to this product is the Evertz standard limited warranty, stated in the sales contract or order confirmation form.

Although every attempt has been made to accurately describe the features, installation and operation of this product in this manual, no warranty is granted nor liability assumed in relation to any errors or omissions unless specifically undertaken in the Evertz sales contract or order confirmation. Information contained in this manual is periodically updated and changes will be incorporated into subsequent editions. If you encounter an error, please notify Evertz Customer Service department. Evertz reserves the right, without notice or liability, to make changes in equipment design or specifications.

This page left intentionally blank

TABLE OF CONTENTS

1. OVERVIEW	1
1.1. 3505FR-32-BNC4 FRAME	2
1.2. 3505FR-64-BNC2 FRAME	3
1.3. 3505FR-DIN FRAME	4
1.4. 3505FR-XLINK FRAME	5
2. INSTALLATION	7
2.1. CONNECTING THE POWER	7
2.2. POWER SUPPLY STATUS INDICATORS	8
2.3. FAN INSTALLATION AND REMOVAL (3505FM FAN MODULE)	8
2.3.1. Cooling	9
2.4. CARE AND HANDLING OF OPTICAL FIBER	10
2.4.1. Safety	10
2.4.2. Assembly	11
2.4.3. Labeling	11
2.4.4. Handling and Connecting Fibers	11
2.5. FIBER INPUT AND OUTPUT CONNECTIONS	12
2.5.1. Electro Static Discharge (ESD) Precautions	13
2.5.2. 3505FR-32-BNC4 SFP Module Variants	14
2.5.3. 3505FR-64-BNC2 Module Variants	15
2.5.4. 3505FR-DIN SFP Module Variants	17
2.5.5. 3505FR-XLINK SFP Module Variants	19
2.5.6. Installing an SFP Module	20
2.5.7. Removing an SFP Module	21
2.6. ELECTRICAL INPUT AND OUTPUT CONNECTIONS	21
2.6.1. Rear Panel BNC Connections	21
2.6.2. Rear Panel DIN Connections	22
2.6.3. Rear Panel XLINK Connections	22
2.7. SERVICING INSTRUCTIONS	26
2.8. CHANGING THE FUSES	26
3. TECHNICAL SPECIFICATIONS	27
3.1. 3505FR-32-BNC4 FRAME	27
3.2. 3505FR-64-BNC2 FRAME	27

3.3.	3505FR-DIN FRAME	27
3.4.	3505FR-XLINK FRAME.....	27
3.5.	COMMUNICATION AND CONTROL.....	27
3.6.	OPTICAL OUTPUT	27
3.7.	OPTICAL INPUT	28
3.8.	ELECTRICAL INPUTS (3505FR-BNC & 3505FR-DIN ONLY)	28
3.9.	ELECTRICAL OUTPUTS (3505FR-BNC & 3505FR-DIN ONLY)	28
3.10.	PHYSICAL	29
3.11.	ELECTRICAL.....	29
3.12.	COMPLIANCE.....	29
4.	STATUS AND LEDS.....	31
4.1.1.	STATUS LED	31
4.1.2.	SFP Monitoring LEDs.....	32
5.	CONFIGURATION AND CONTROL	33
5.1.	3505 FRAME CONTROLLER CONFIGURATION.....	33
5.2.	VISTALINK® CONFIGURATION	34
5.2.1.	General Tab	34
5.2.2.	TX/RX Configuration Tabs.....	36
5.2.2.1.	Tx Configuration	38
5.2.2.2.	Rx Configuration	38
5.2.3.	Faults Tab	38
5.2.4.	Network Parameters Tab.....	41
5.2.5.	Trap Destination Tab.....	42
5.2.6.	FC Faults Tab	42
6.	VISTALINK® MONITORING/CONTROL	43
6.1.	WHAT IS VISTALINK®?	43
6.2.	VISTALINK® MONITORED PARAMETERS.....	43
6.3.	VISTALINK® TRAPS	44
6.4.	VISTALINK® CONTROLLED PARAMETERS	44

FIGURES

Figure 1-1: 3505FR-32-BNC4 Frame	2
Figure 1-2: 3505FR-32-BNC4 Block Diagram	2
Figure 2-1: 3505PS Status Indicators	8
Figure 2-2: Front View of 3505FM	8
Figure 2-3: Cooling Fan Installation and Removal.....	10
Figure 2-4: Reproduction of Laser Certification and Identification Label.....	11
Figure 2-5: 3505FR Front View.....	12
Figure 2-6: 3505FR-DIN Front View	12
Figure 2-7: Evertz [®] SFP Modules	13
Figure 2-8: 3505FR-32-BNC Fixed Electrical Connections	21
Figure 2-9: 3505FR-64-BNC Fixed Electrical Connections	21
Figure 2-10: 3505FR-DIN Fixed Electrical Connections.....	22
Figure 2-11: 3505FR-XLINK Fixed Electrical Connections.....	22
Figure 4-1: Front of 3505FC	31
Figure 5-1: 3405T13-2 VistaLINK [®] General Tab	34
Figure 5-2: 3405T13-R VistaLINK [®] General Tab.....	34
Figure 5-3: 3405OO13-DA4 VistaLINK [®] General Tab	35
Figure 5-4: 3405R-2 VistaLINK [®] General Tab	35
Figure 5-5: 3405R-2R VistaLINK [®] General Tab	35
Figure 5-6: 3405T13-2 VistaLINK [®] TX Configuration Tab	36
Figure 5-7: 3405T13-R VistaLINK [®] TX Configuration Tab	36
Figure 5-8: 3405OO13-DA4 VistaLINK [®] RX Configuration Tab	37
Figure 5-9: 3405R-2 VistaLINK [®] RX Configuration Tab	37
Figure 5-10: 3405R-2R VistaLINK [®] RX Configuration Tab.....	38
Figure 5-11: 3405T13-2 VistaLINK [®] Faults Tab	39
Figure 5-12: 3405T13-R VistaLINK [®] Faults Tab.....	39
Figure 5-13: 3405OO13-DA4 VistaLINK [®] Faults Tab.....	40
Figure 5-14: 3405R-2 VistaLINK [®] Faults Tab	40
Figure 5-15: 3405R-2R VistaLINK [®] Faults Tab	41
Figure 5-16: 3505FC VistaLINK [®] Network Parameter Tab.....	41
Figure 5-17: 3505FC VistaLINK [®] Trap Destination Tab	42
Figure 5-18: 3505FC VistaLINK [®] FC Faults Tab	42

TABLES

Table 1-1: Frame Versions	1
Table 2-1: XLINK Connector Mapping with 3405R Series Dual Receiver SFP's Installed.....	23
Table 2-2: XLINK Connector Mapping with 3405T Series Dual Transmitter SFP's Installed	24
Table 2-3: XLINK Connector Mapping with 3505Txx-2-C Series Combining Transmitter SFP's Installed	25
Table 4-1: Status LED Chart.....	31
Table 4-2: SFP LED Chart	32
Table 6-1: VistaLINK [®] Monitoring	43
Table 6-2: VistaLINK [®] Traps	44
Table 6-3: VistaLINK [®] Controlled Parameters	44

This page left intentionally blank

1. OVERVIEW

The Evertz 3505FR Series SFP frame is the ideal solution for today's low cost, high density fiber optic/X-LINK distribution needs. The 3505FR Series provides the flexibility to handle the high-speed requirements of 3G and HDTV as well as SD-SDI, SDTi, and DVB-ASI.

All components are hot swappable through the front of the frame including SFP's, frame controllers, multiplexers, and power converters. This ensures the unit can be fully serviceable in the field without having to be de-cabled or removed from the customers rack.

The 3505FR Series is a 2RU frame designed to house up to 64 Evertz® SFP modules. This provides up to 128 EO or OE in two rack units of space. The frame can be configured for a mixture of transmit, receive and distribution modules.

The unit supports extraction of the SFP modules from the front without compromising performance. The frame can be configured for a variety of modules. The 3505FR frame is available in four versions as shown in Table 1-1.

Model	Description	Connector	Density
3505FR-32-BNC4	Fiber Optic SFP BNC Frame	BNC	Up to 64 EO, OE, or mixture of EO and OE in a 2RU unit
3505FR-64-BNC2	Fiber Optic SFP BNC Frame	BNC	Up to 128 EO, OE, or mixture of EO and OE in a 2RU unit
3505FR-DIN	Fiber Optic SFP DIN Frame	Mini DIN	Up to 128 EO, OE, or mixture of EO and OE in a 1RU unit
3505FR-XLINK	Fiber Optic SFP X-LINK Frame	X-LINK	Up to 128 EO or 128 OE X-LINK conversions in a 1RU unit

Table 1-1: Frame Versions

Features:

- Dual Power supplies (primary and redundant) and conversion trays (front extractable)
- Houses up to 64 front loading Evertz SFP modules
- Each slot can be used as an input or an output based on SFP type
- Dual primary & secondary 3505FC Frame Controllers for full VistaLINK® SNMP control and monitoring
- No electrical re-cabling required when hot swapping modules
- The industry's highest density optical conversion platform with up to 128 EO or 128 OE or (for any combination thereof) in 2RU

1.1. 3505FR-32-BNC4 FRAME

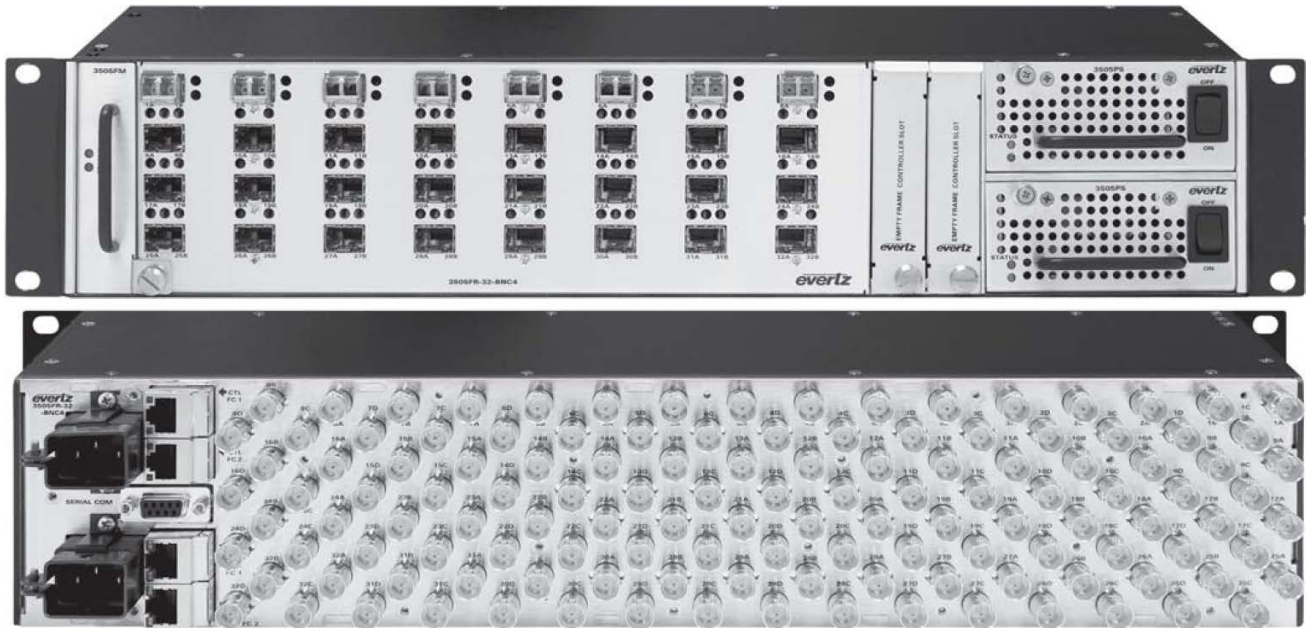

Figure 1-1: 3505FR-32-BNC4 Frame

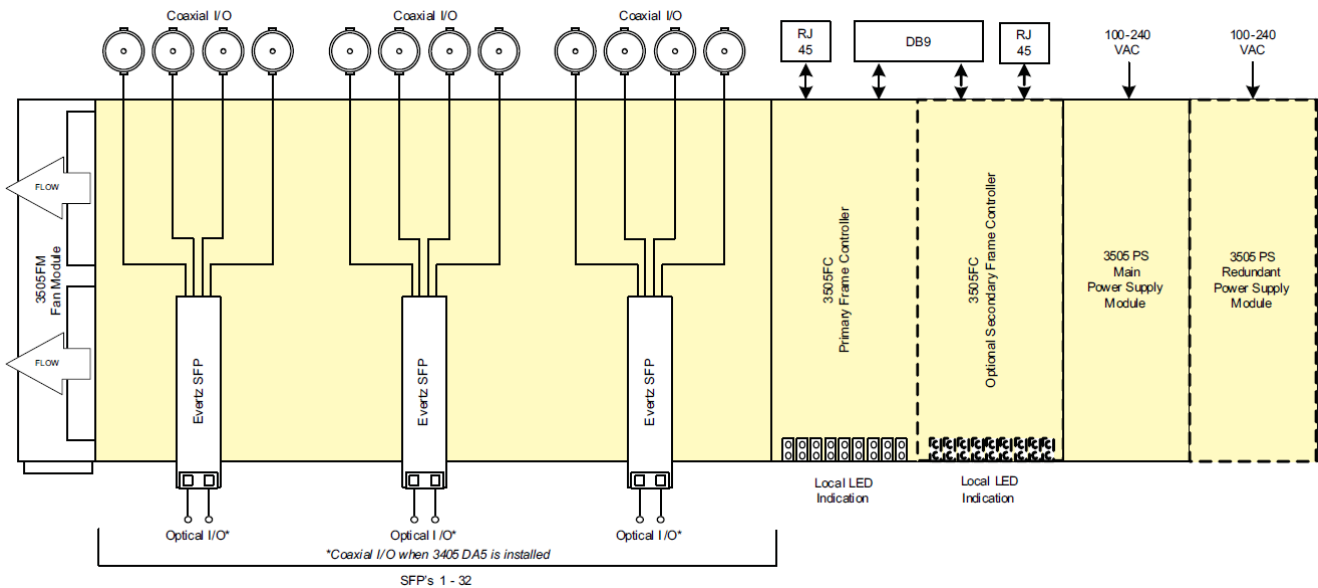

Figure 1-2: 3505FR-32-BNC4 Block Diagram

1.2. 3505FR-64-BNC2 FRAME

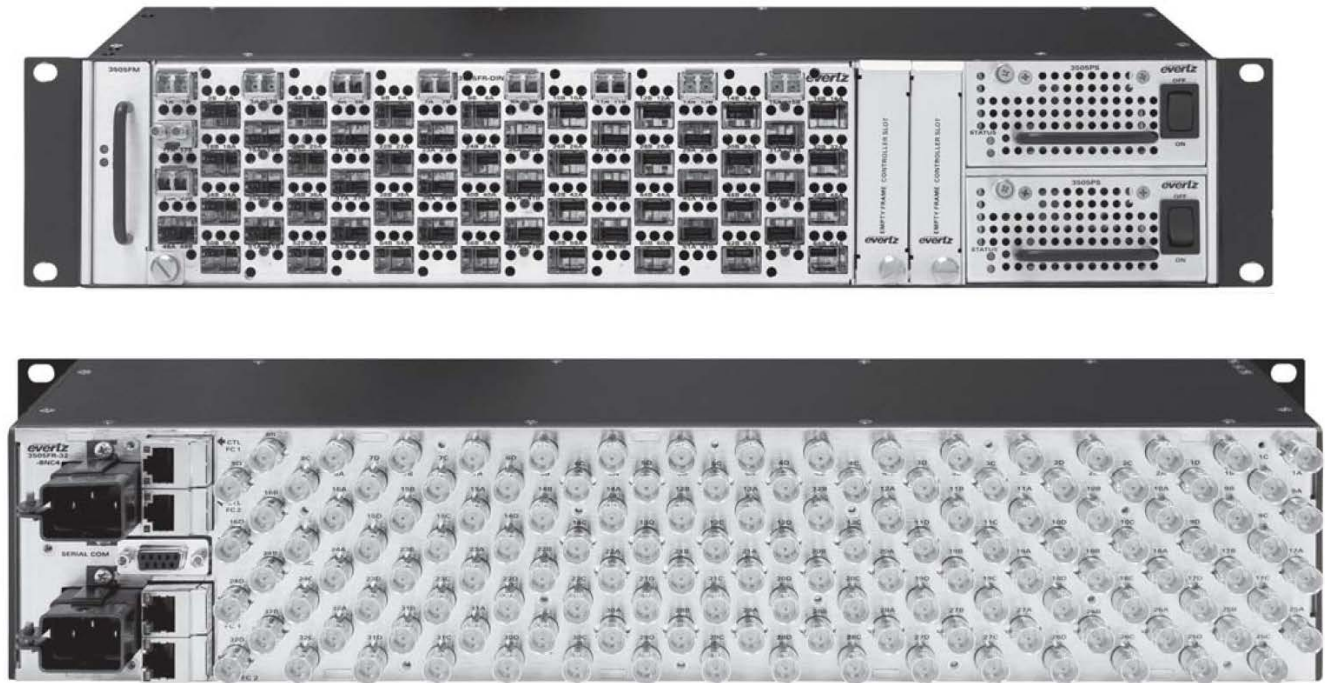

Figure 1-3: 3505FR-64-BNC2 Frame

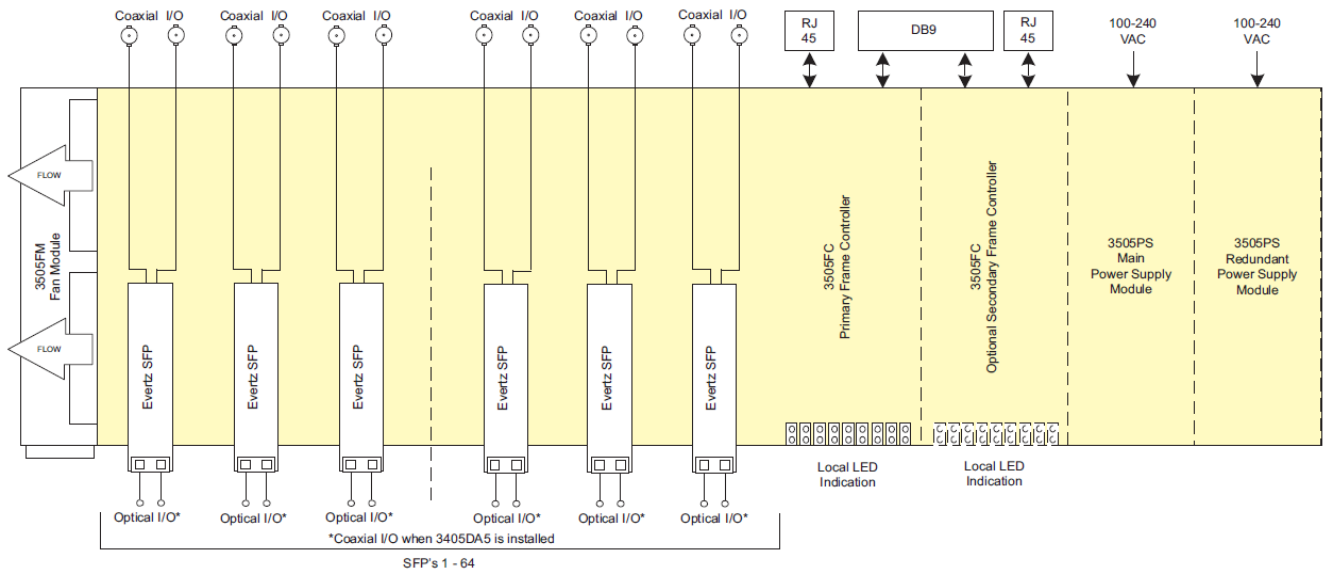

Figure 1-4: 3505FR-64-BNC2 Block Diagram

1.3. 3505FR-DIN FRAME

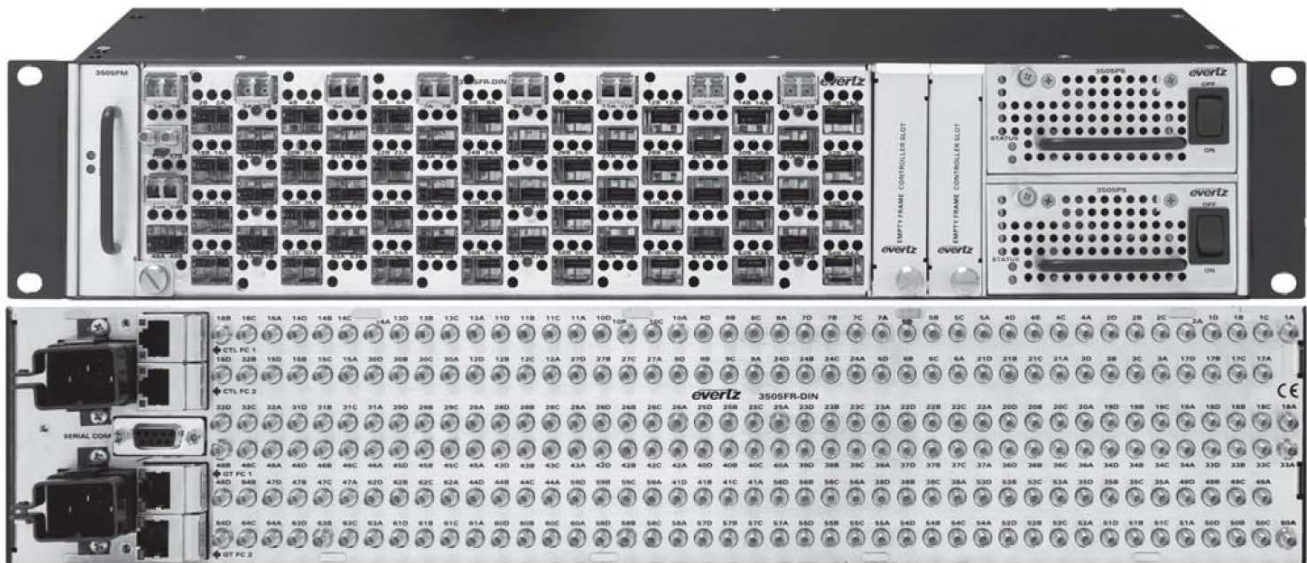

Figure 1-5: 3505FR-DIN Frame

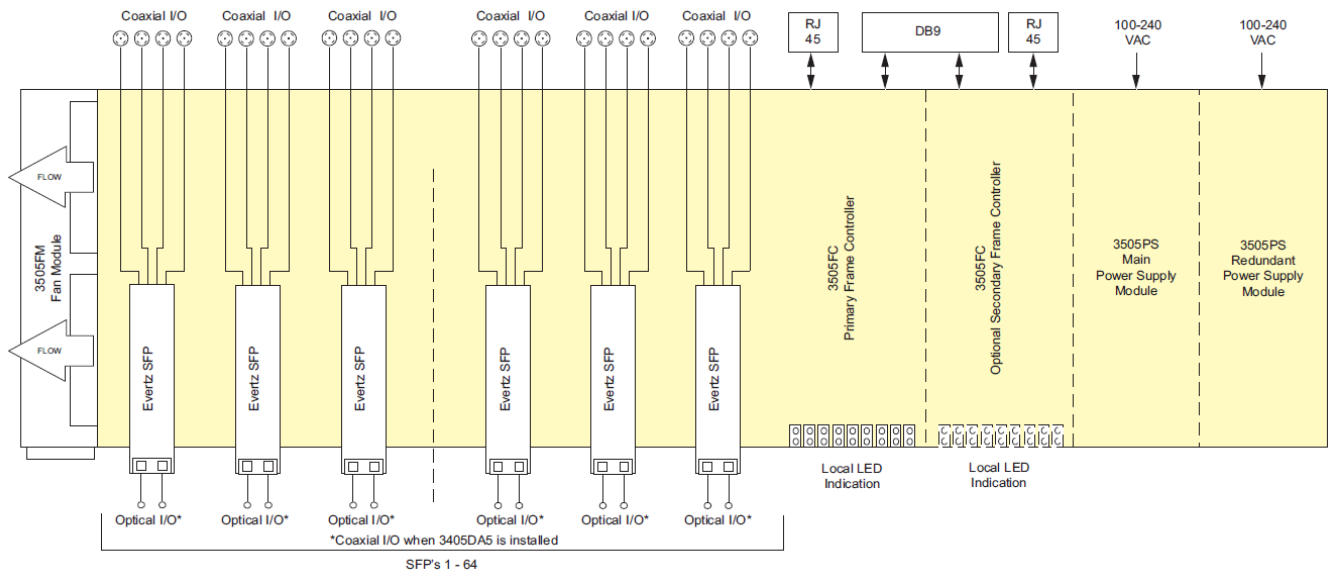

Figure 1-6: 3505FR-DIN Block Diagram

1.4. 3505FR-XLINK FRAME

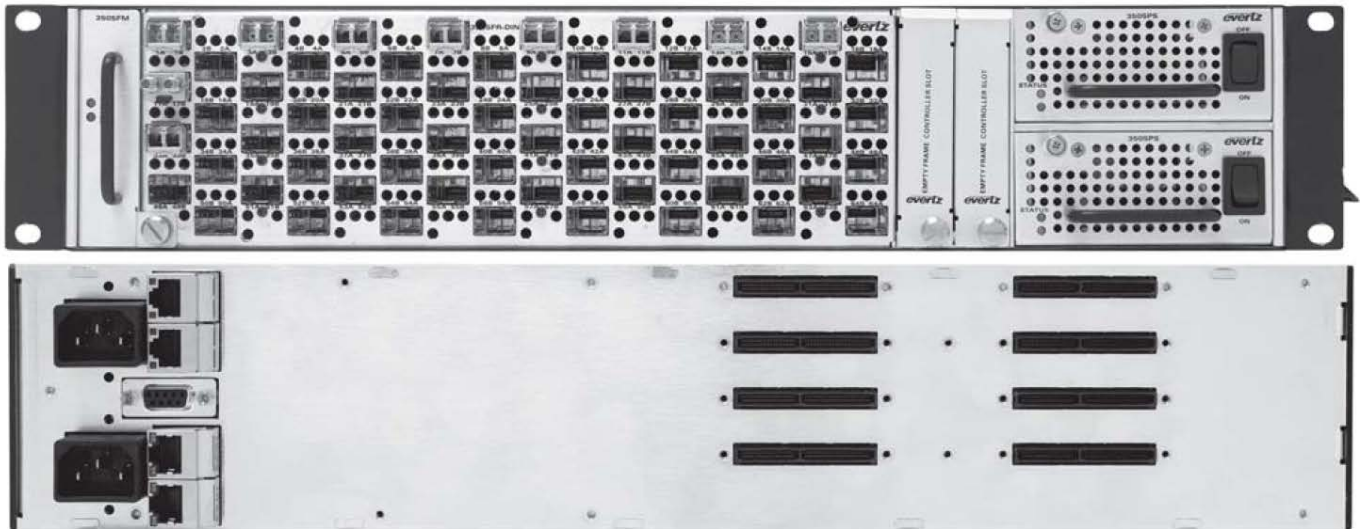

Figure 1-7: 3505FR-XLINK Frame

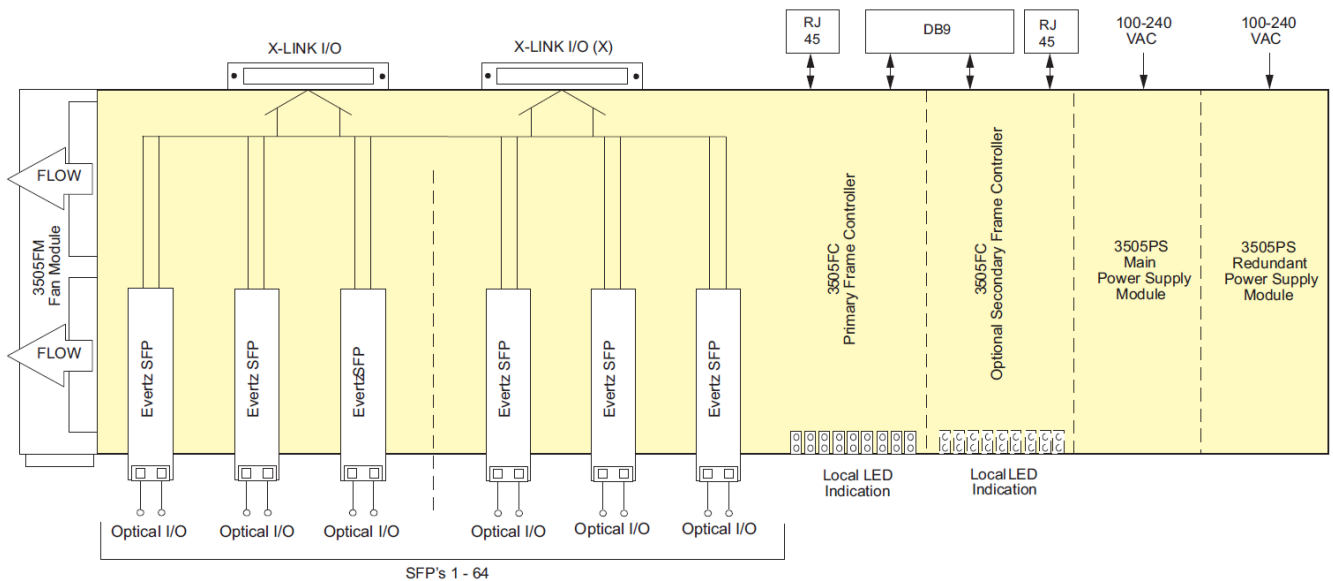

Figure 1-8: 3505FR-XLINK Block Diagram

This page left intentionally blank

2. INSTALLATION

The 3505FR Series frames require 3 rack units (i.e. 3.5 inches (90 mm) of standard 19 inch (483 mm) wide rack space). To firmly fasten the frame to the equipment rack, make sure that all four mounting screws are securely tightened.

2.1. CONNECTING THE POWER

The frames come standard with one auto-ranging power supply that automatically senses the input voltage over the range of 100 to 240 VAC. An additional power supply can be ordered to provide fully redundant powering of the frame. When only one power supply is fitted, the frame will be fitted with the appropriate fan module (3505FM Fan Module) to ensure the thermal integrity of the frame cooling. Power should be applied by connecting a 3-wire grounding type power supply cord to the power entry module on the rear panel of each power supply. The power cord should be minimum 18 AWG wire size; type SVT marked VW-1, maximum 2.5 m in length.



CAUTION - TO REDUCE THE RISK OF ELECTRIC SHOCK, EARTHING OF THE EARTH PIN OF THE MAINS PLUG MUST BE MAINTAINED

The power entry modules contain a standard IEC power inlet connector and an EMI line filter. A separate fuse holder is provided for each AC input. The fuse holder is located on each side the front panel of the frame.

See section 2.8 for information on changing the fuses.

Fuse Rating: 4 amps, 250 Volt time delay 5 x 20 mm



If there is a fuse failure, contact Evertz customer service regarding the power supply immediately. The power supplies are short circuit protected and should not blow the fuse under a short circuit condition.

2.2. POWER SUPPLY STATUS INDICATORS

The 3505PS power supply tray has 2 status indicator LEDs. The green status indicator LED indicates fault free operation of the PS unit. The red status indicator LED indicates a faulty 3505PS unit.

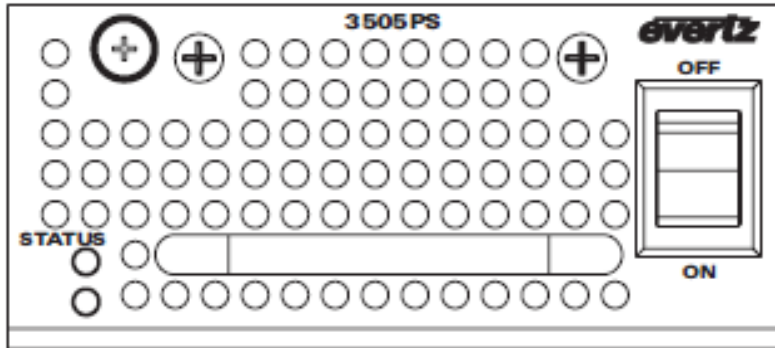

Figure 2-1: 3505PS Status Indicators

2.3. FAN INSTALLATION AND REMOVAL (3505FM FAN MODULE)

Figure 2-2 provides an illustration of the 3505FM front view.

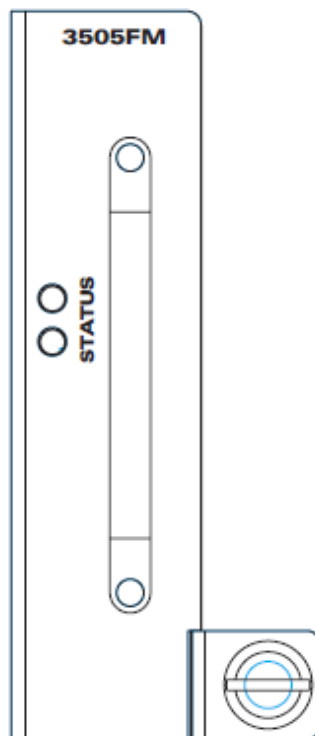
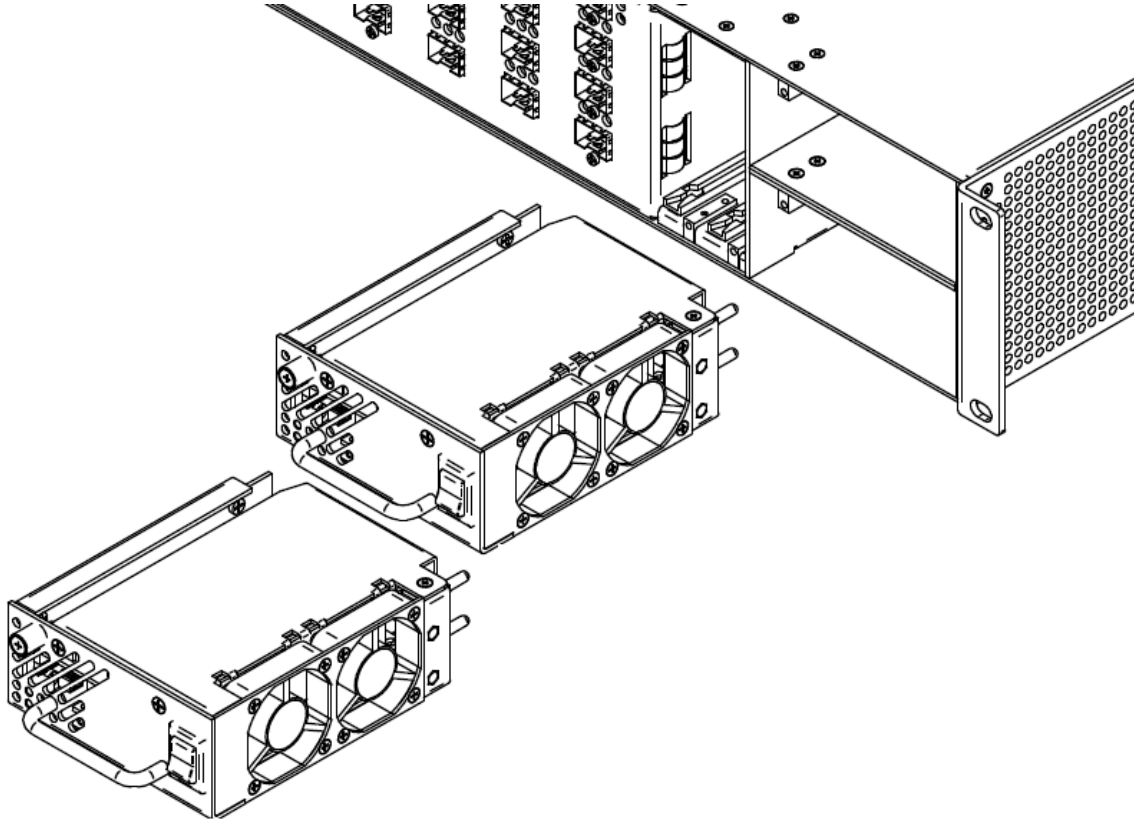

Figure 2-2: Front View of 3505FM



2.3.1. Cooling

The 3505FR frame is designed to ensure adequate cooling for up to 40 watts of processing power per frame. Fans at the sides of the frame accomplish forced air cooling. Adjacent equipment may be mounted immediately to the top and bottom of the 3505FR frame. Additional module cooling is provided by interior cooling channels to ensure that even fully loaded frames mounted adjacent to each other will operate within the normal temperature range.

The 3505FM module is capable of cooling the 3505FR from an operating ambient temperature of 0-40°C.

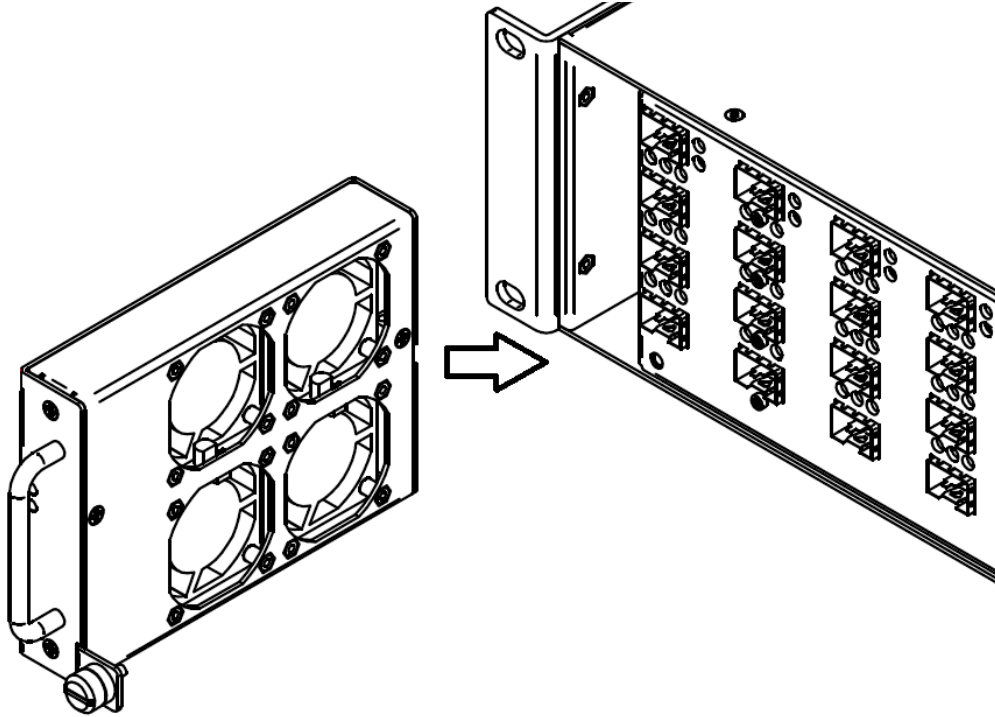

Figure 2-3: Cooling Fan Installation and Removal

If necessary, the cooling fans can be removed for the purposes of fan replacement. Always ensure that this procedure is applied while the frame is off. Removing the fans will cause unwanted heat build-up in the 3505FR. Undo the captive screw and pull outwards on the metal tab at the bottom of the 3505FM. Installation is the reverse of removal.



CAUTION: To achieve adequate cooling, care should be taken to ensure that the fan inlets and exhaust openings are free of obstructions.

2.4. CARE AND HANDLING OF OPTICAL FIBER

2.4.1. Safety



CLASS 1 LASER PRODUCT

Background colour: yellow
Triangular band: black
Symbol: black

2.4.2. Assembly

Assembly or repair of the Evertz® SFP modules is done only at Evertz facility and performed only by qualified Evertz technical personnel.

2.4.3. Labeling

Certification and Identification labels are combined into one label. As there is inadequate space on the product to place the label, it is reproduced here in the manuals.

- There is no date of manufacture on this label as it can be traced by bar code label placed on the Evertz® SFP module.
- The model number of the SFPs containing lasers is one of: 3405T13-2, 3405Txx/yy-2, 3405R-2, 3405R-2R, 3405OO13-DA4, and 3405OOxx-DA4.
where xx and yy = 27, 29, 31, 33, 35, 37, 43, 45, 47, 49, 51, 53, 55, 57, 59, 61

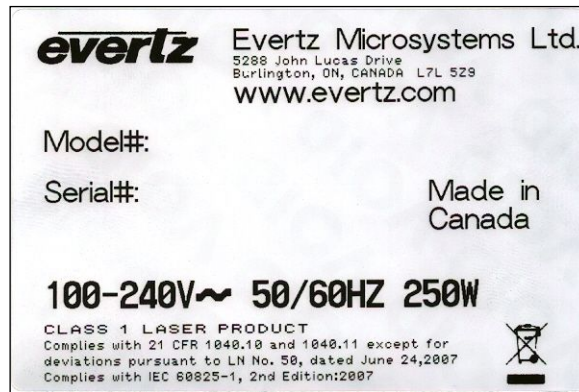

Figure 2-4: Reproduction of Laser Certification and Identification Label

2.4.4. Handling and Connecting Fibers



CAUTION: Never touch the end face of an optical fiber. Always keep dust caps on optical fiber connectors when not connected and always remember to properly clean the optical end face of a connector before making a connection.

The transmission characteristics of the fiber are dependent on the shape of the optical core and therefore care must be taken to prevent fiber damage due to heavy objects or abrupt fiber bending. Evertz recommends that the user maintains a minimum bending radius of 5 cm to avoid fiber-bending loss that will decrease the maximum attainable distance of the fiber cable. For further information about care and handling of fiber optic cable see the Evertz website. (<http://www.evertz.com/resources/>)

2.5. FIBER INPUT AND OUTPUT CONNECTIONS

These connections are made using standard LC fiber connector ends on single mode fiber optic cable. There are a total of 16 dual SFP slots. There can be a mix of 32 fiber inputs or outputs on the 3505FR front panel. A high quality fiber optic cable such as Corning SMF-28 or suitable equivalents should be used for optimum performance. Compatible SFP modules currently come in four configurations: dual transmitters, dual receivers, reclocking transmitter, and reclocking receiver.

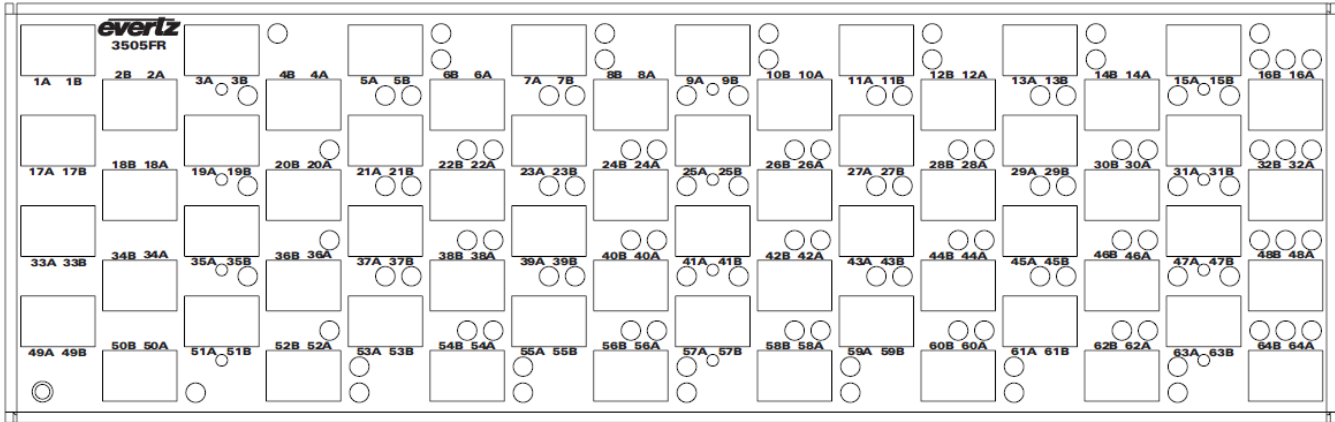

Figure 2-5: 3505FR Front View

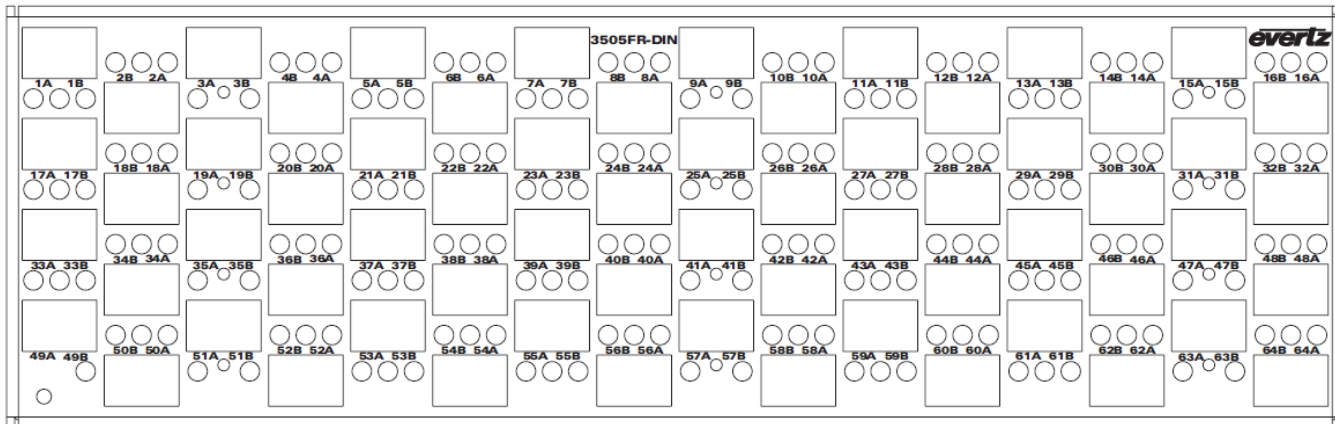

Figure 2-6: 3505FR-DIN Front View

Unpopulated SFP slots will remain inactive until the appropriate SFP is installed. Please ensure flat or ultra flat polished fiber LC connectors are used for the SFPs.



NOTE: Channels A and B on the front of the 3505FR frame correspond to channels A and B on the rear of the frame (Figure 2-8).

Figure 2-7 depicts any one of the following Evertz® SFP modules: 3405T13-2, 3405Txx/yy-2, 3405R-2, 3405R-2R, 3405OO13-DA4, and 3405OOxx-DA4.



Figure 2-7: Evertz[®] SFP Modules

The SFP fiber modules are equipped with a class 1 laser and emit invisible radiation. Avoid exposure to the laser emitter and do not stare directly into unconnected SFP emitter ports or fiber ends that are connected to SFP ports.

- It is recommended that trained and qualified personnel install, replace or handle this equipment.
- Ensure ESD precautions are followed during SFP installation.
- Store SFP modules in static bags and wear an ESD strap when handling the optical modules. SFP modules are also dust sensitive.
- To prevent dust from entering the apertures of an SFP module, keep plugs inserted into the optical bores.
- Do not repeatedly remove and insert SFP modules more often than necessary. Repeated removals and insertions of an SFP module can shorten its life.

2.5.1. Electro Static Discharge (ESD) Precautions



All semiconductor devices are sensitive to ESD. To prevent any damage or degradation on components of the product caused by ESD, observe these precautions when installing or removing modules from the frame.

1. Discharge static from your body. Wear a grounded anti-static wrist or heel strap, to discharge the static voltage from your body.
2. Use a Safe Work Area. Avoid handling modules in areas that have a floor or work surface covering capable of generating a static charge. Also nothing capable of generating or holding a static charge should be allowed in the work area.
3. Handle ESD sensitive modules carefully. Do not slide modules over any surface. Do not touch exposed connector pins. Pick-up modules by the edges of the modules, never by touching exposed leads.
4. Transport and store sensitive components or assemblies in a static-protected bag or container.

2.5.2. 3505FR-32-BNC4 SFP Module Variants

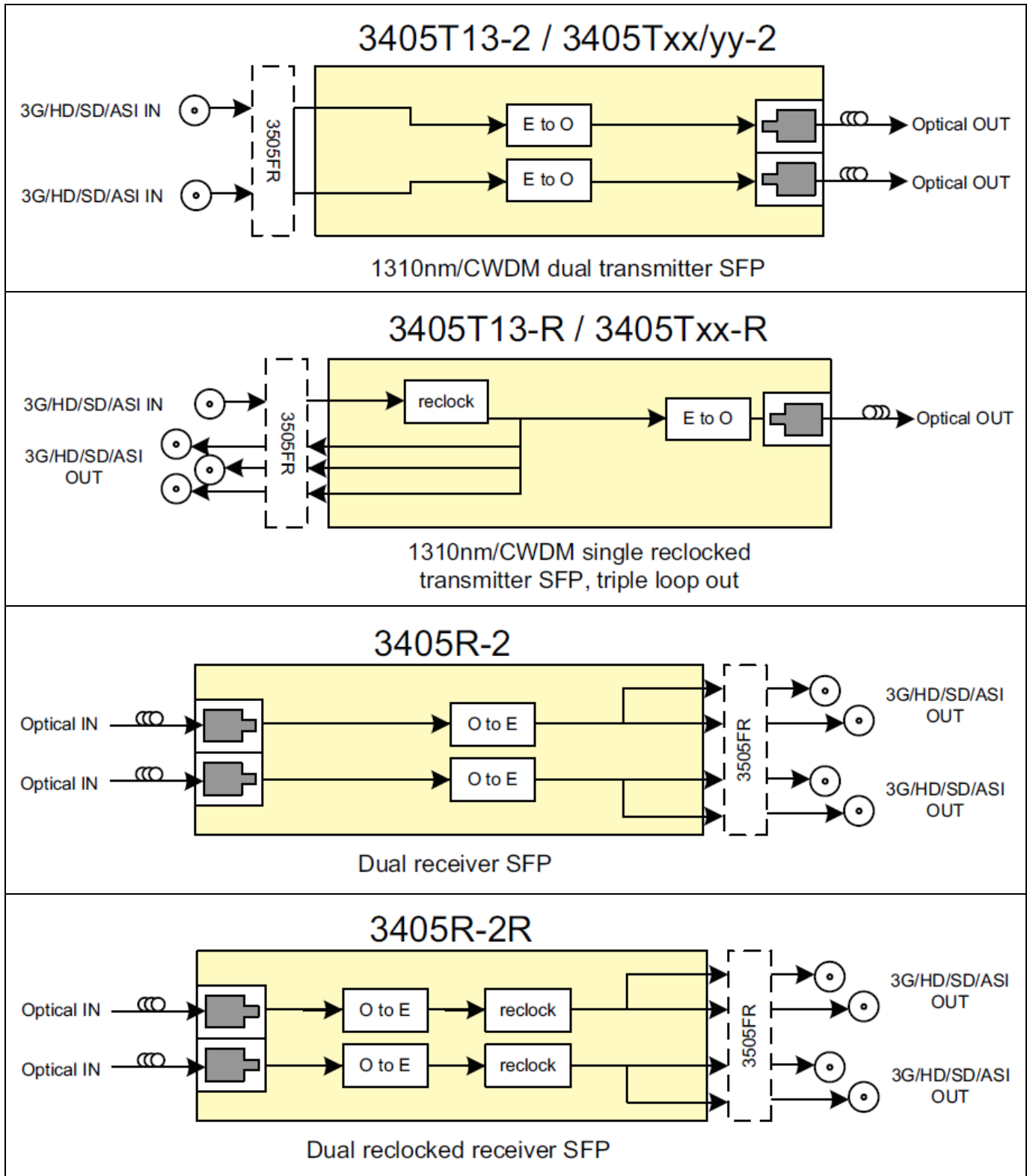

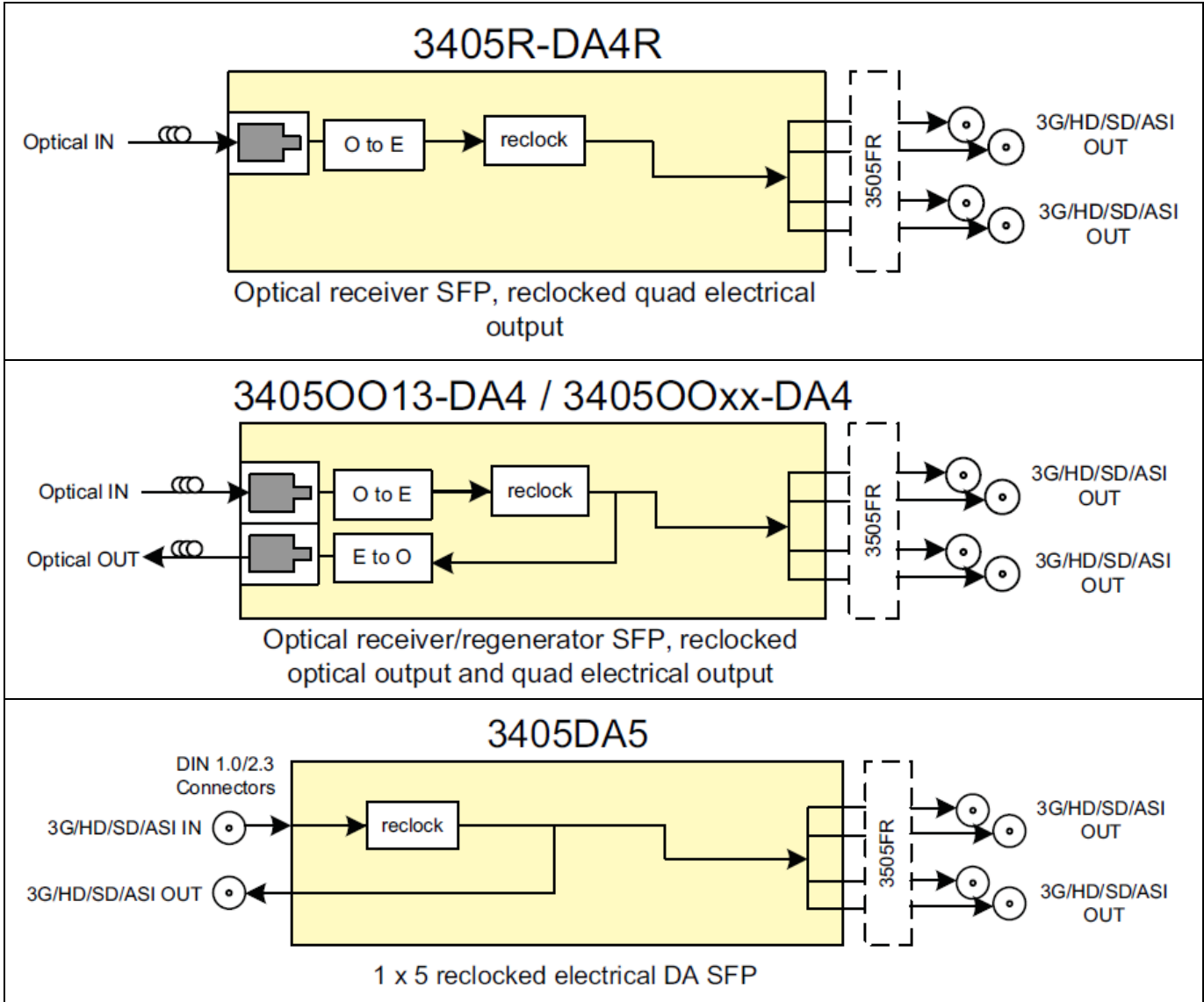

2.5.3. 3505FR-64-BNC2 Module Variants

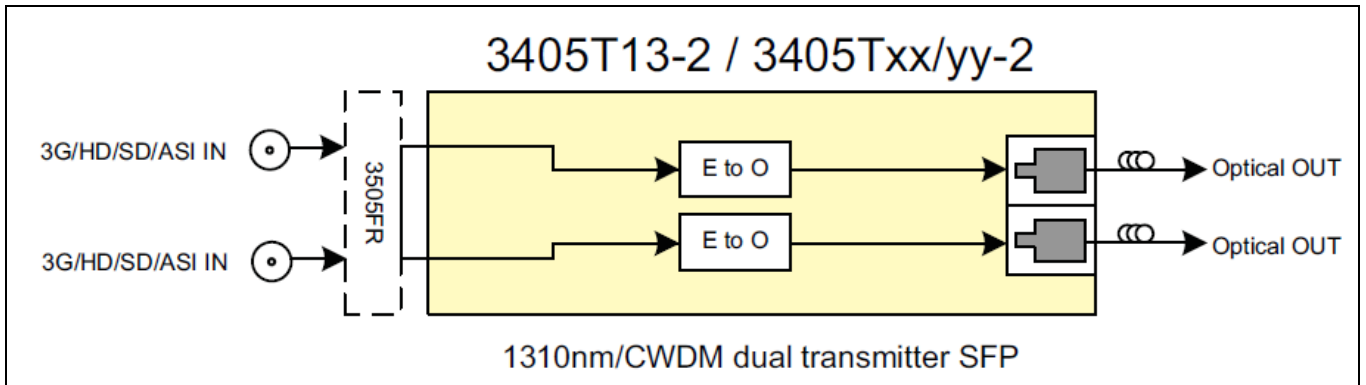

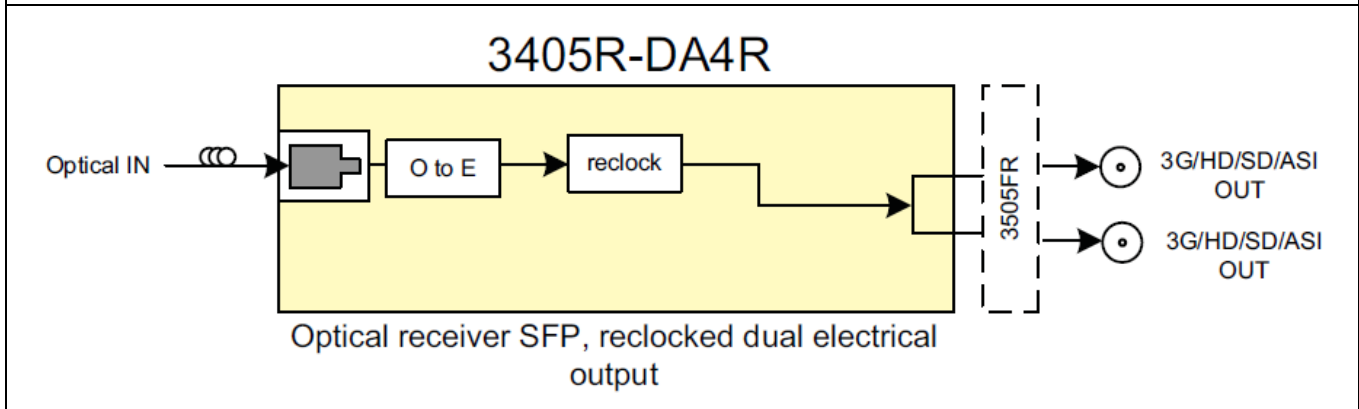
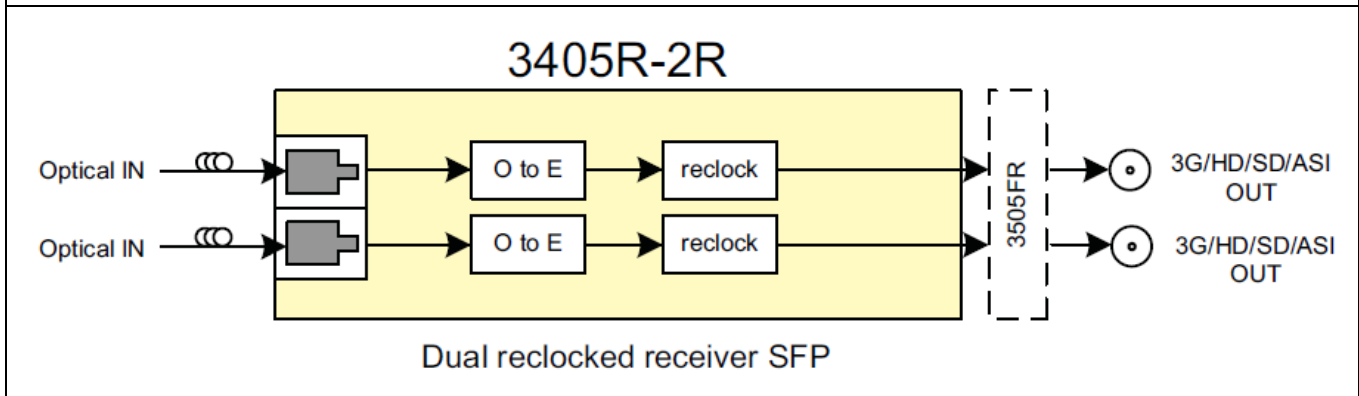
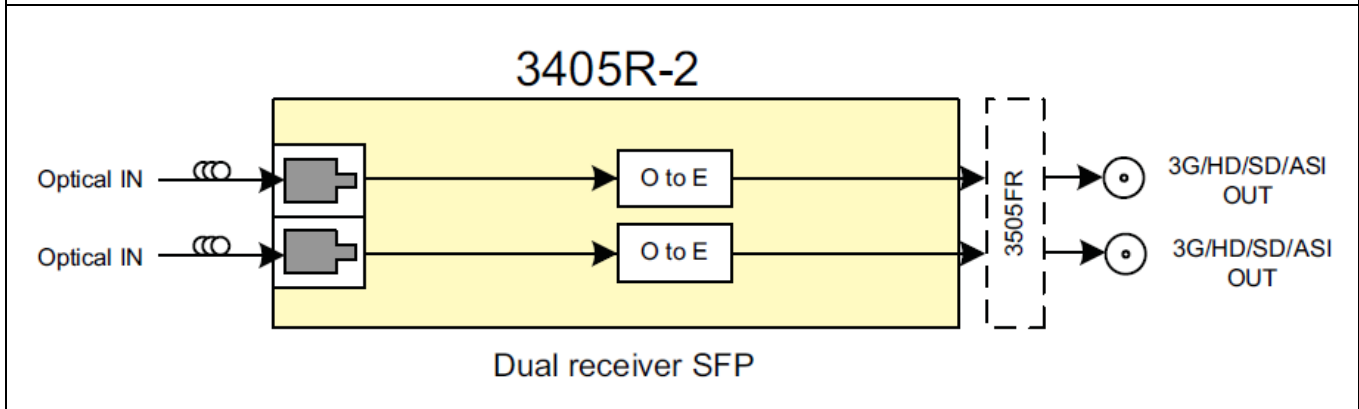
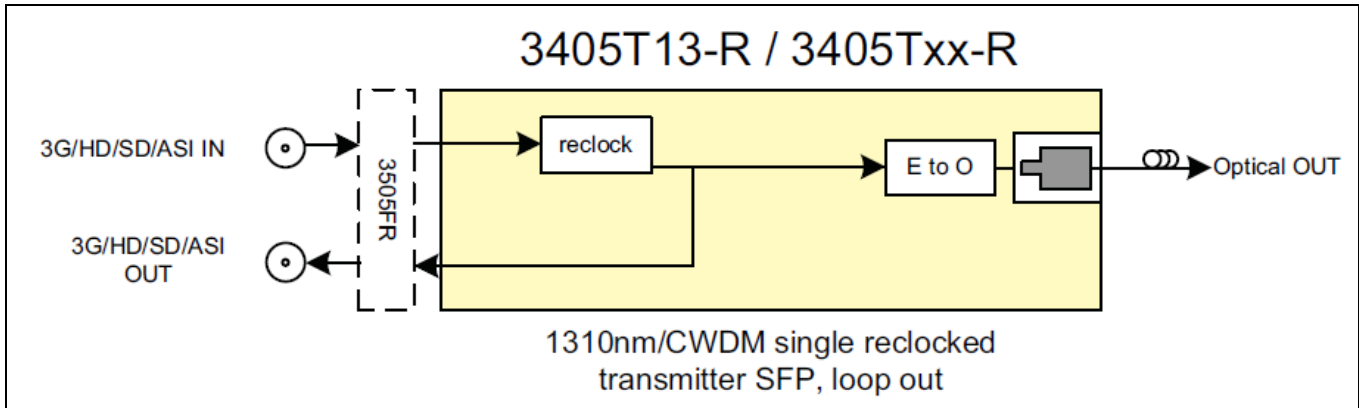

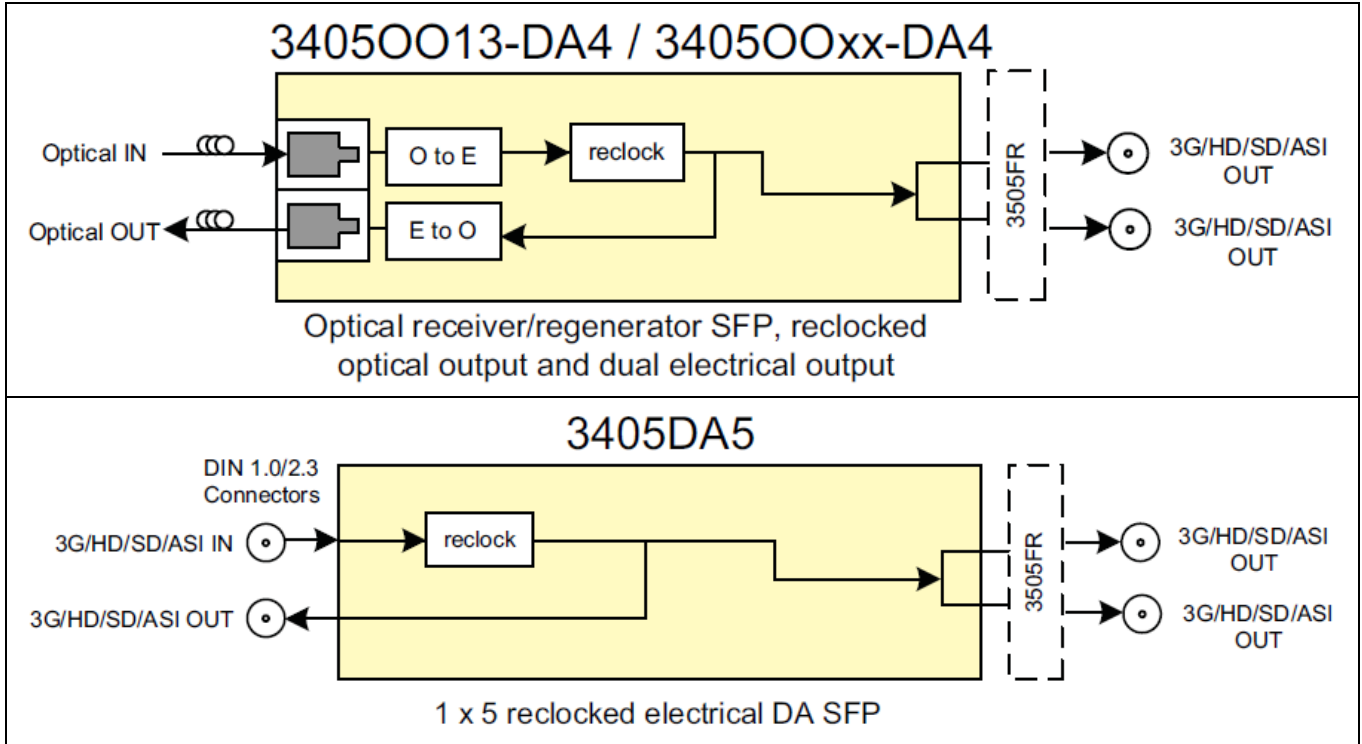

2.5.4. 3505FR-DIN SFP Module Variants

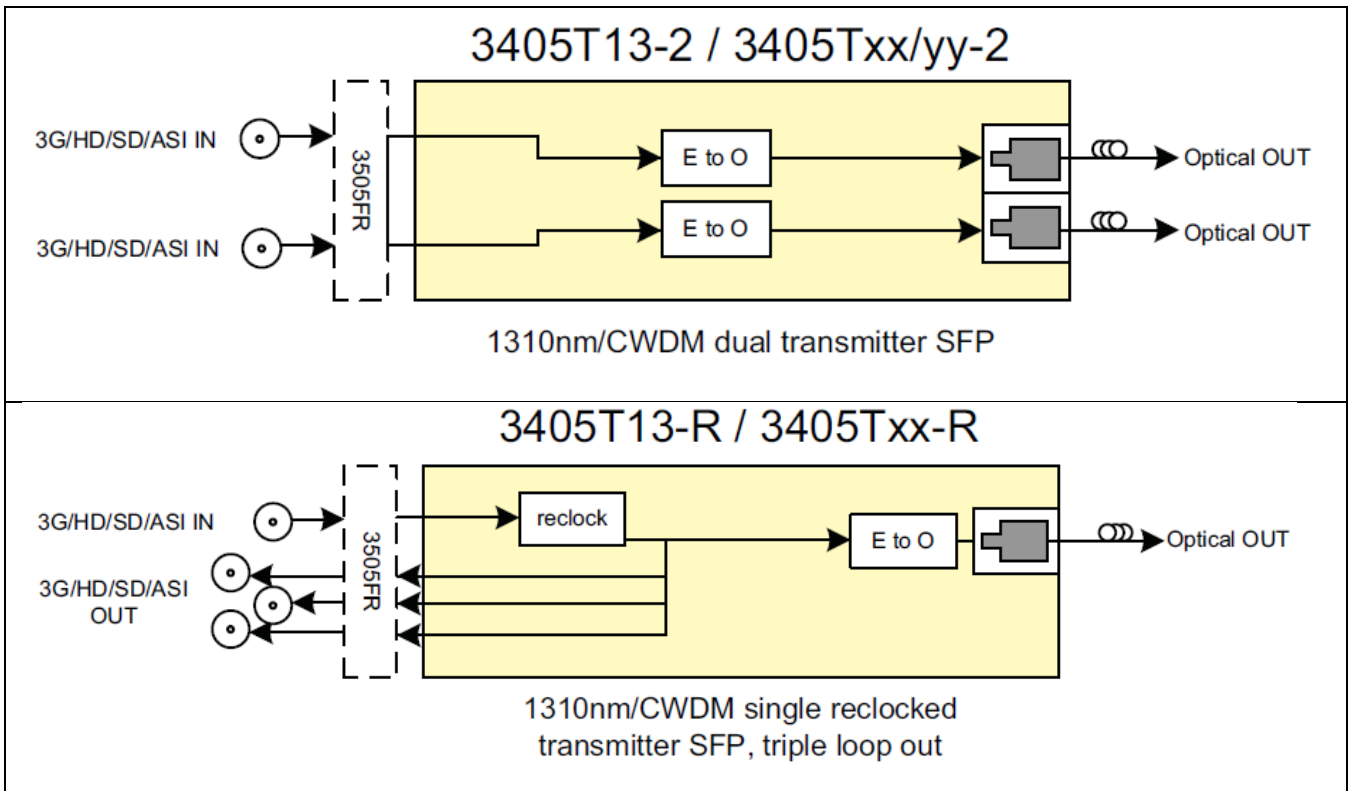

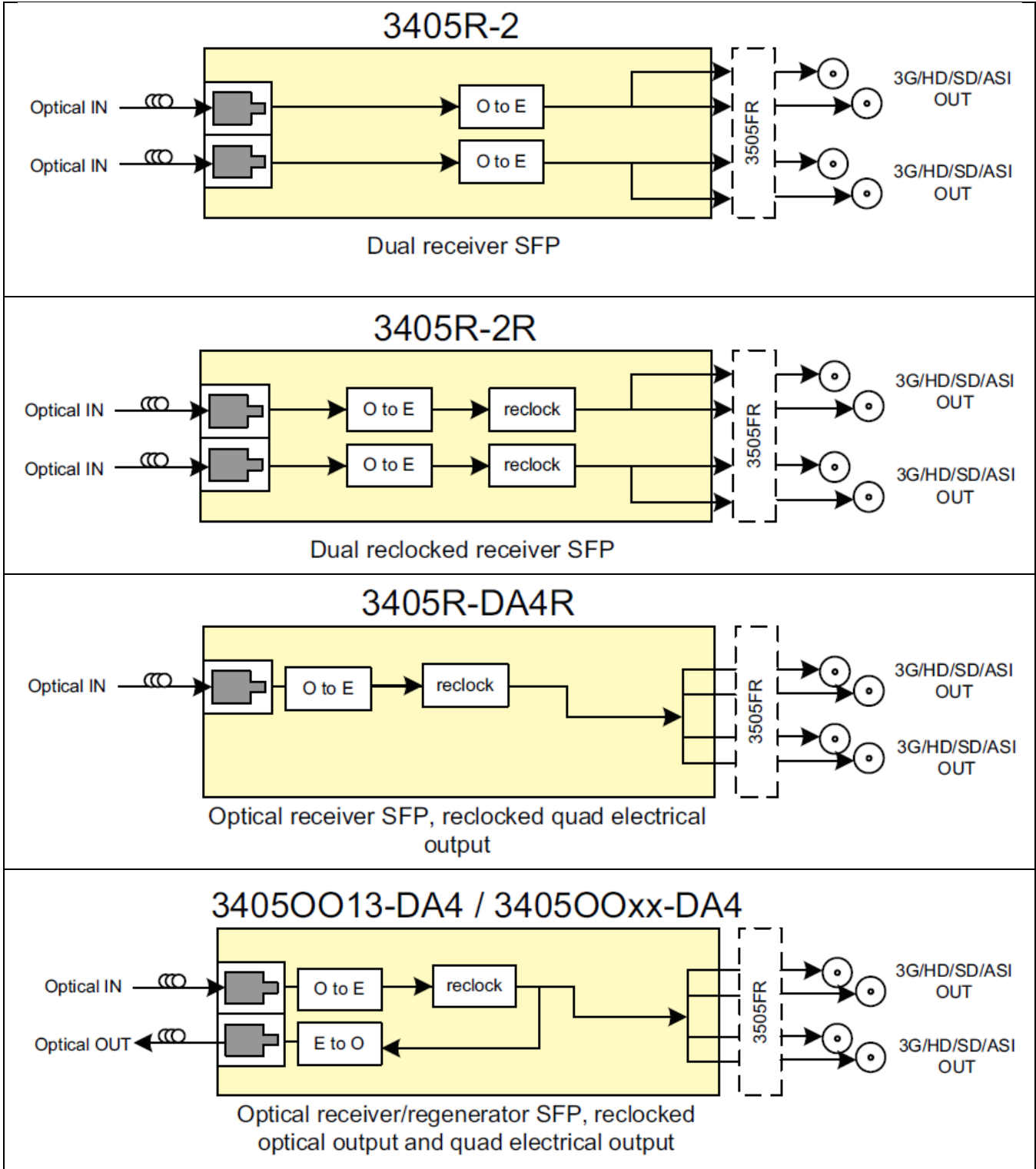

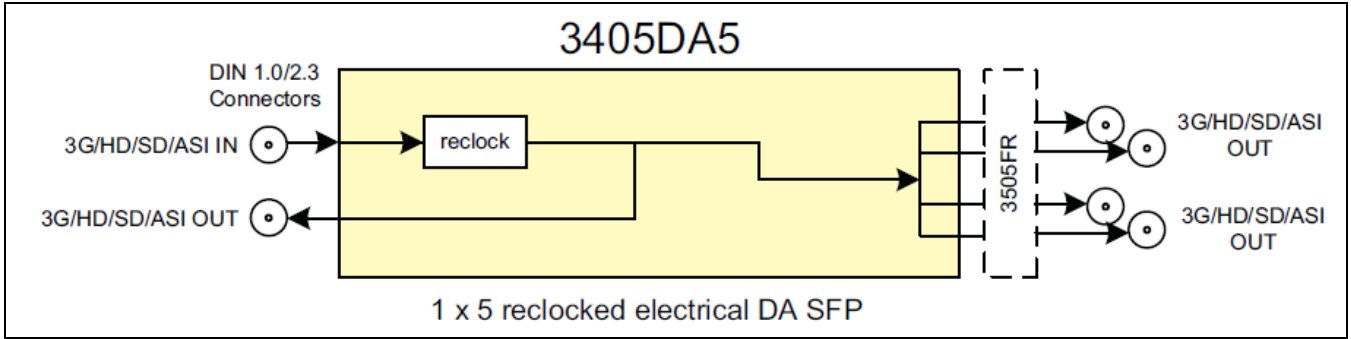

2.5.5. 3505FR-XLINK SFP Module Variants

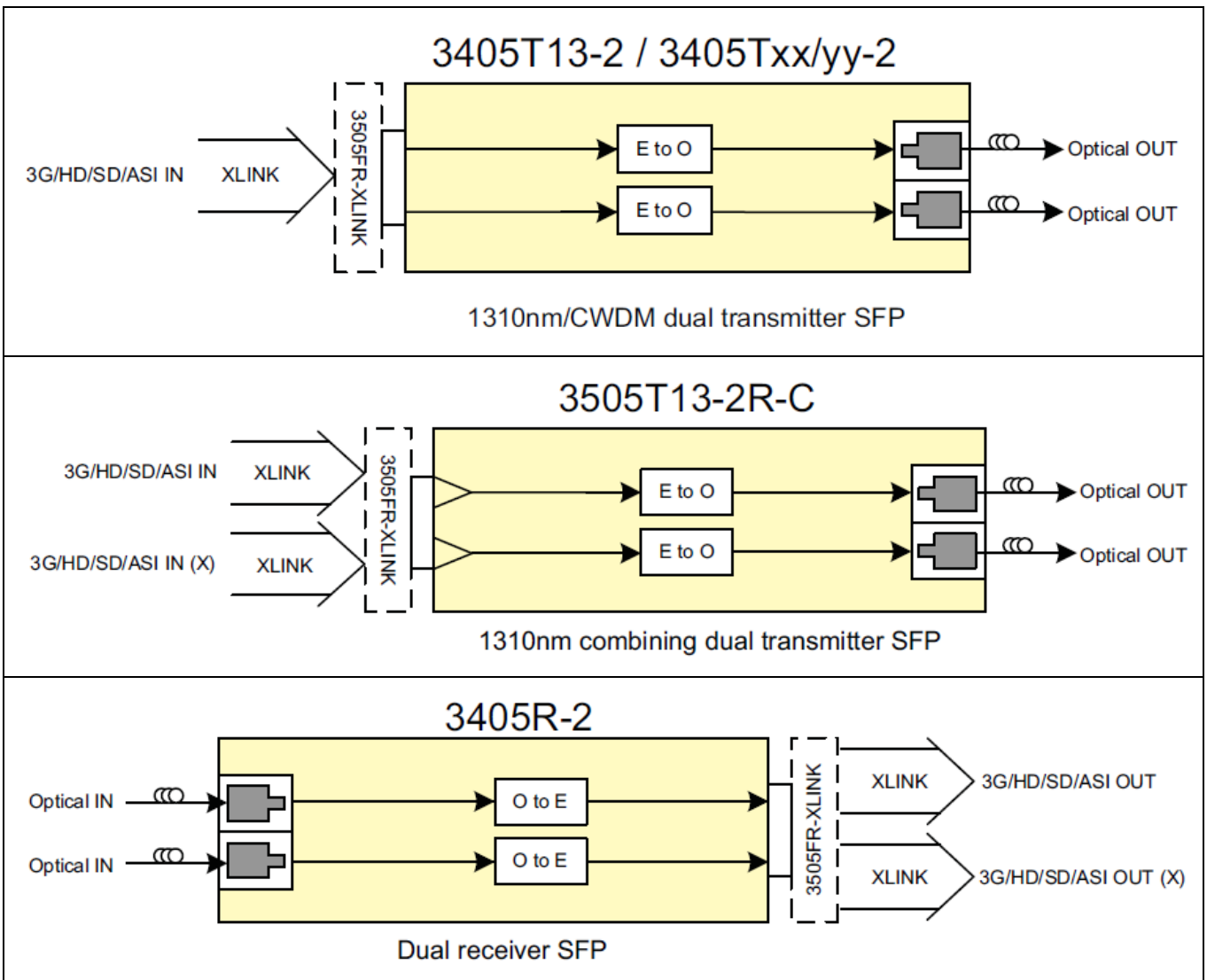

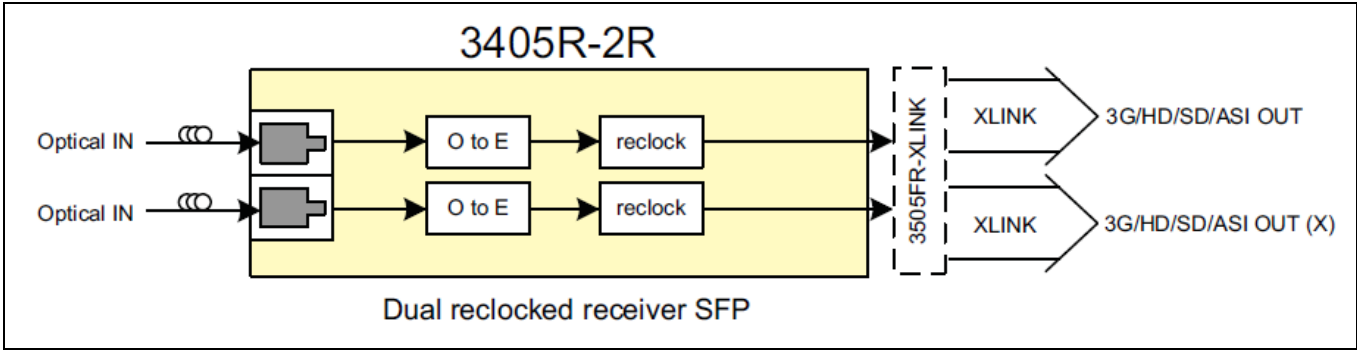

2.5.6. Installing an SFP Module



Note: In most cases, SFP modules will come from the factory preinstalled into its respective slot. The following steps outline the procedure for replacing or installing a new SFP module.

1. Remove the SFP module from its protective packaging. You can identify if your particular SFP module is a duplex transmitter or duplex receiver. Observe the top of the SFP module. The part number is located on the top of the SFP module. For example, a 3405T-2 part number denotes a duplex transmitter module (output) and a 3405R-2 denotes a duplex receiver module (input). A 3405T13-R part number denotes a reclocking simplex transmitter module (output) and a 3405OO13-DA4 denotes a reclocking simplex receiver module (input).
2. Hold the sides of the SFP module between your thumb and forefinger, position the alignment grooves on the sides of the SFP with the corresponding guides in the SFP slot on your module.
3. Slide the SFP gently but firmly into the SFP slot. You should hear a click when the clips on either side of the SFP snap into place, locking the SFP in the port receptacle.



NOTE: Do not remove the dust plugs from the optical bores of the SFP or the dust caps from the fiber-optic cable until you are ready to connect the cable. The plugs and caps protect the SFP optical ports and the cable connectors from contamination.

2.5.7. Removing an SFP Module



NOTE: It is strongly recommended that SFP modules are not installed or removed with fiber-optic cables attached. Doing so may cause damage to the cables, the connectors, or the optical interfaces in the SFP module. Disconnect all cables before removing or installing SFP modules.

1. Pull the bale-clasp latch out and down to eject the module. If the latch is obstructed and you are not able to release the clasp, use a small flat-blade screwdriver or other narrow flat instrument to open the bale-clasp latch.
2. Grasp the SFP module between your thumb and index finger and carefully remove the SFP from its slot.
3. Place the removed SFP module into an anti-static bag, or other ESD protective container.

2.6. ELECTRICAL INPUT AND OUTPUT CONNECTIONS

2.6.1. Rear Panel BNC Connections

The BNC's on the rear of the 3505FR-BNC are fixed and correspond to a particular SFP module. These BNC connectors are agile and thus configured as inputs or outputs. A BNC will become an electrical input if its corresponding SFP spigot is an optical transmitter (Electrical to Optical converter). Conversely a BNC will become an electrical output if its corresponding SFP spigot is an optical receiver (Optical to Electrical converter).

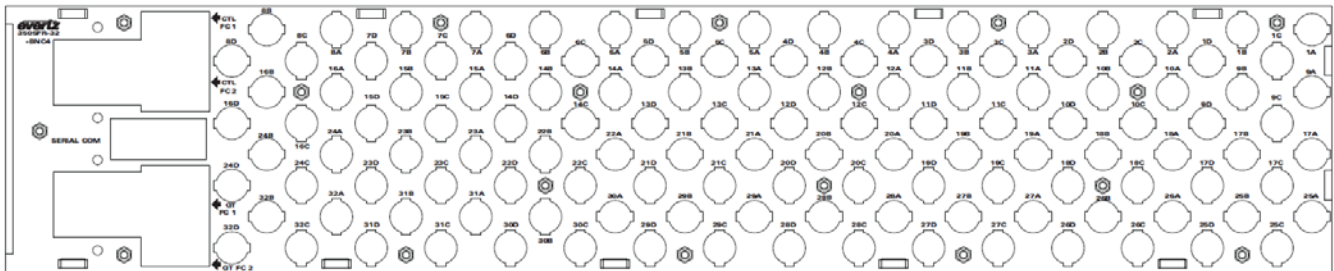

Figure 2-8: 3505FR-32-BNC Fixed Electrical Connections

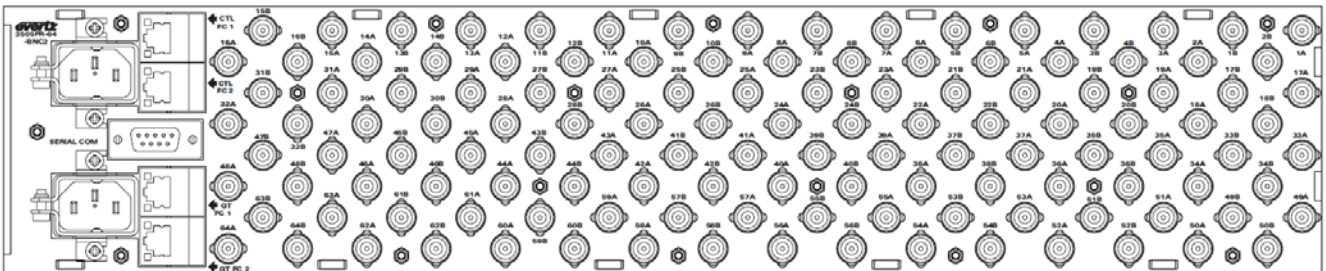

Figure 2-9: 3505FR-64-BNC Fixed Electrical Connections



NOTE: Channels A and B on the front of the 3505FR-BNC frame (Figure 2-5) correspond to channels A and B on the rear of the frame.

2.6.2. Rear Panel DIN Connections

A group of 4 MiniDINs on the rear of the 3505FR-DIN are fixed and correspond to a particular SFP module. These BNC MiniDINs are agile and are assigned as inputs or outputs depending on the type of SFP inserted. For detailed input and output assignments, please see section 2.5.3.

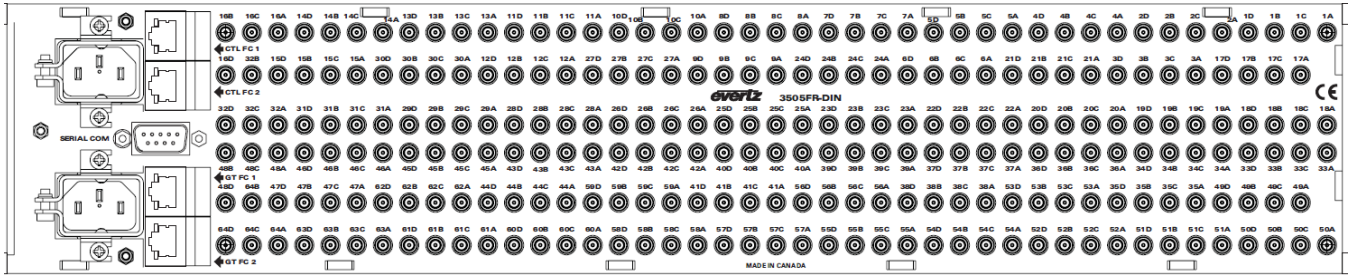

Figure 2-10: 3505FR-DIN Fixed Electrical Connections



NOTE: Channels A and B on the front of the 3505FR-DIN frame (Figure 2-5) correspond to channels A and B on the rear of the frame.

2.6.3. Rear Panel XLINK Connections

The X-LINK IO's on the rear of the 3505FR-XLINK are fixed and correspond to a particular SFP module. This X-LINK connector is agile and thus configured as inputs or outputs. An X-LINK connector will become an electrical input if its corresponding SFP spigot is an optical transmitter (Electrical to Optical converter). Conversely the X-LINK connector will become an electrical output if its corresponding SFP spigot is an optical receiver (Optical to Electrical converter).

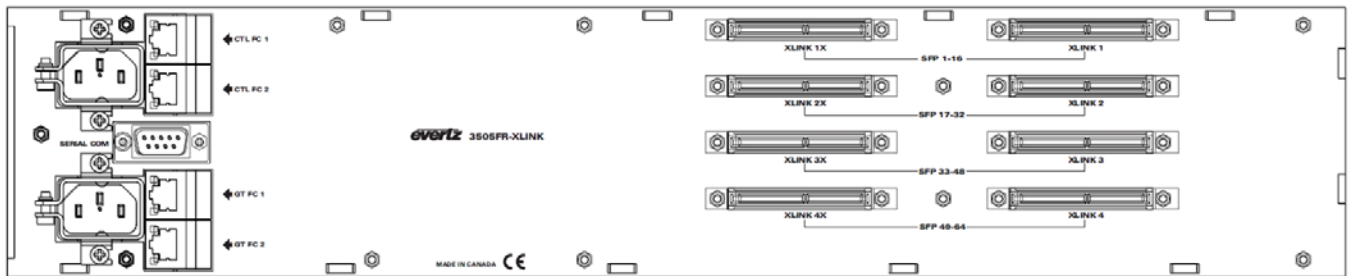

Figure 2-11: 3505FR-XLINK Fixed Electrical Connections

The following is the mapping scheme between the XLINK input/output connector pin numbers to the SFP port locations. Please note that there are three tables corresponding to use with dual receiver SFP's, dual transmitter SFP's or combining dual transmitter SFP's.

3505FR-XLINK											
XLINK1	XLINK1X	SFP	XLINK2	XLINK2X	SFP	XLINK3	XLINK3X	SFP	XLINK4	XLINK4X	SFP
1	1	1A	1	1	17A	1	1	33A	1	1	49A
2	2	1B	2	2	17B	2	2	33B	2	2	49B
3	3	2A	3	3	18A	3	3	34A	3	3	50A
4	4	2B	4	4	18B	4	4	34B	4	4	50B
5	5	3A	5	5	19A	5	5	35A	5	5	51A
6	6	3B	6	6	19B	6	6	35B	6	6	51B
7	7	4A	7	7	20A	7	7	36A	7	7	52A
8	8	4B	8	8	20B	8	8	36B	8	8	52B
9	9	5A	9	9	21A	9	9	37A	9	9	53A
10	10	5B	10	10	21B	10	10	37B	10	10	53B
11	11	6A	11	11	22A	11	11	38A	11	11	54A
12	12	6B	12	12	22B	12	12	38B	12	12	54B
13	13	7A	13	13	23A	13	13	39A	13	13	55A
14	14	7B	14	14	23B	14	14	39B	14	14	55B
15	15	8A	15	15	24A	15	15	40A	15	15	56A
16	16	8B	16	16	24B	16	16	40B	16	16	56B
17	17	9A	17	17	25A	17	17	41A	17	17	57A
18	18	9B	18	18	25B	18	18	41B	18	18	57B
19	19	10A	19	19	26A	19	19	42A	19	19	58A
20	20	10B	20	20	26B	20	20	42B	20	20	58B
21	21	11A	21	21	27A	21	21	43A	21	21	59A
22	22	11B	22	22	27B	22	22	43B	22	22	59B
23	23	12A	23	23	28A	23	23	44A	23	23	60A
24	24	12B	24	24	28B	24	24	44B	24	24	60B
25	25	13A	25	25	29A	25	25	45A	25	25	61A
26	26	13B	26	26	29B	26	26	45B	26	26	61B
27	27	14A	27	27	30A	27	27	46A	27	27	62A
28	28	14B	28	28	30B	28	28	46B	28	28	62B
29	29	15A	29	29	31A	29	29	47A	29	29	63A
30	30	15B	30	30	31B	30	30	47B	30	30	63B
31	31	16A	31	31	32A	31	31	48A	31	31	64A
32	32	16B	32	32	32B	32	32	48B	32	32	64B

Table 2-1: XLINK Connector Mapping with 3405R Series Dual Receiver SFP's Installed

3505FR-XLINK											
XLINK1	XLINK1X	SFP	XLINK2	XLINK2X	SFP	XLINK3	XLINK3X	SFP	XLINK4	XLINK4X	SFP
1	N/C	1A	1	N/C	17A	1	N/C	33A	1	N/C	49A
2	N/C	1B	2	N/C	17B	2	N/C	33B	2	N/C	49B
3	N/C	2A	3	N/C	18A	3	N/C	34A	3	N/C	50A
4	N/C	2B	4	N/C	18B	4	N/C	34B	4	N/C	50B
5	N/C	3A	5	N/C	19A	5	N/C	35A	5	N/C	51A
6	N/C	3B	6	N/C	19B	6	N/C	35B	6	N/C	51B
7	N/C	4A	7	N/C	20A	7	N/C	36A	7	N/C	52A
8	N/C	4B	8	N/C	20B	8	N/C	36B	8	N/C	52B
9	N/C	5A	9	N/C	21A	9	N/C	37A	9	N/C	53A
10	N/C	5B	10	N/C	21B	10	N/C	37B	10	N/C	53B
11	N/C	6A	11	N/C	22A	11	N/C	38A	11	N/C	54A
12	N/C	6B	12	N/C	22B	12	N/C	38B	12	N/C	54B
13	N/C	7A	13	N/C	23A	13	N/C	39A	13	N/C	55A
14	N/C	7B	14	N/C	23B	14	N/C	39B	14	N/C	55B
15	N/C	8A	15	N/C	24A	15	N/C	40A	15	N/C	56A
16	N/C	8B	16	N/C	24B	16	N/C	40B	16	N/C	56B
17	N/C	9A	17	N/C	25A	17	N/C	41A	17	N/C	57A
18	N/C	9B	18	N/C	25B	18	N/C	41B	18	N/C	57B
19	N/C	10A	19	N/C	26A	19	N/C	42A	19	N/C	58A
20	N/C	10B	20	N/C	26B	20	N/C	42B	20	N/C	58B
21	N/C	11A	21	N/C	27A	21	N/C	43A	21	N/C	59A
22	N/C	11B	22	N/C	27B	22	N/C	43B	22	N/C	59B
23	N/C	12A	23	N/C	28A	23	N/C	44A	23	N/C	60A
24	N/C	12B	24	N/C	28B	24	N/C	44B	24	N/C	60B
25	N/C	13A	25	N/C	29A	25	N/C	45A	25	N/C	61A
26	N/C	13B	26	N/C	29B	26	N/C	45B	26	N/C	61B
27	N/C	14A	27	N/C	30A	27	N/C	46A	27	N/C	62A
28	N/C	14B	28	N/C	30B	28	N/C	46B	28	N/C	62B
29	N/C	15A	29	N/C	31A	29	N/C	47A	29	N/C	63A
30	N/C	15B	30	N/C	31B	30	N/C	47B	30	N/C	63B
31	N/C	16A	31	N/C	32A	31	N/C	48A	31	N/C	64A
32	N/C	16B	32	N/C	32B	32	N/C	48B	32	N/C	64B

Table 2-2: XLINK Connector Mapping with 3405T Series Dual Transmitter SFP's Installed

3505FR-XLINK											
XLINK1	XLINK1X	SFP	XLINK2	XLINK2X	SFP	XLINK3	XLINK3X	SFP	XLINK4	XLINK4X	SFP
1	1	1A	1	1	17A	1	1	33A	1	1	49A
2	2	1B	2	2	17B	2	2	33B	2	2	49B
3	3	2A	3	3	18A	3	3	34A	3	3	50A
4	4	2B	4	4	18B	4	4	34B	4	4	50B
5	5	3A	5	5	19A	5	5	35A	5	5	51A
6	6	3B	6	6	19B	6	6	35B	6	6	51B
7	7	4A	7	7	20A	7	7	36A	7	7	52A
8	8	4B	8	8	20B	8	8	36B	8	8	52B
9	9	5A	9	9	21A	9	9	37A	9	9	53A
10	10	5B	10	10	21B	10	10	37B	10	10	53B
11	11	6A	11	11	22A	11	11	38A	11	11	54A
12	12	6B	12	12	22B	12	12	38B	12	12	54B
13	13	7A	13	13	23A	13	13	39A	13	13	55A
14	14	7B	14	14	23B	14	14	39B	14	14	55B
15	15	8A	15	15	24A	15	15	40A	15	15	56A
16	16	8B	16	16	24B	16	16	40B	16	16	56B
17	17	9A	17	17	25A	17	17	41A	17	17	57A
18	18	9B	18	18	25B	18	18	41B	18	18	57B
19	19	10A	19	19	26A	19	19	42A	19	19	58A
20	20	10B	20	20	26B	20	20	42B	20	20	58B
21	21	11A	21	21	27A	21	21	43A	21	21	59A
22	22	11B	22	22	27B	22	22	43B	22	22	59B
23	23	12A	23	23	28A	23	23	44A	23	23	60A
24	24	12B	24	24	28B	24	24	44B	24	24	60B
25	25	13A	25	25	29A	25	25	45A	25	25	61A
26	26	13B	26	26	29B	26	26	45B	26	26	61B
27	27	14A	27	27	30A	27	27	46A	27	27	62A
28	28	14B	28	28	30B	28	28	46B	28	28	62B
29	29	15A	29	29	31A	29	29	47A	29	29	63A
30	30	15B	30	30	31B	30	30	47B	30	30	63B
31	31	16A	31	31	32A	31	31	48A	31	31	64A
32	32	16B	32	32	32B	32	32	48B	32	32	64B

Table 2-3: XLINK Connector Mapping with 3505Txx-2-C Series Combining Transmitter SFP's Installed

2.7. SERVICING INSTRUCTIONS



CAUTION – These servicing instructions are for use by qualified service personnel only. To reduce risk of electric shock, do not perform any servicing instructions in this section of the manual unless you are qualified to do so.

2.8. CHANGING THE FUSES



If there is a fuse failure, contact Evertz customer service regarding the power supply immediately. The power supplies are short circuit protected and should not blow the fuse under a short circuit condition.

The fuse holders are located on the front of the power tray. To change the fuse for one of the supplies, you should first disconnect the power cord for the power supply. Insert a flat blade screwdriver in the fuse holder and turn clockwise. Pull out the fuse from the fuse holder using a small screwdriver. Remove the blown fuse and replace with a fuse of the correct value. The correct fuse rating is marked on the front panel. Carefully reinsert the fuse into the fuse holder. Tighten by turning the fuse holder counter clockwise.

The correct fuse rating is shown below.

Fuse Rating: 4 amps, 250 Volt time delay, 5 x 20 mm



Check that the line fuse is rated for the correct value. Never replace with a fuse of greater value.

3. TECHNICAL SPECIFICATIONS

3.1. 3505FR-32-BNC4 FRAME

Density:	Up to 64 EO, OE, or mixture of EO and OE in a 2RU unit
Impedance:	75 Ω
Connector:	BNC per IEC 61169-8 Annex A (F-type connector optional)

3.2. 3505FR-64-BNC2 FRAME

Density:	Up to 128 EO, OE, or mixture of EO and OE in a 2RU unit
Impedance:	75 Ω
Connector:	BNC per IEC 61169-8 Annex A (F-type connector optional)

3.3. 3505FR-DIN FRAME

Density:	Up to 128 EO, OE, or mixture of EO and OE in a 2RU unit
Impedance:	75 Ω
Connector:	DIN 1.0/2.3 Female connector

3.4. 3505FR-XLINK FRAME

Density:	Up to 128 EO, OE, or mixture of EO and OE to X-LINK conversion in a 2RU unit
Impedance:	75
Connector:	XLINK

3.5. COMMUNICATION AND CONTROL

Serial:	RS-232 single Female 9 pin D connector
Ethernet:	SNMP over IEEE 802.3/U (10/100 BaseTx) RJ-45 connector
Control:	VistaLINK [®]

3.6. OPTICAL OUTPUT

Number of Outputs:	
3505FR-32-BNC4:	Up to 2 per SFP
3505FR-64-BNC2:	Up to 2 per SFP
3505FR-DIN:	Up to 2 per SFP
3505FR-XLINK:	2 per SFP
Connector:	LC/UPC
Rise/Fall Time:	<270ps
Optical Power:	
Standard:	-2dBm +/- 1dBm
-S (Short haul):	-7dBm +/- 1dBm
CWDM:	+3.5dBm +/- 1dBm
Wavelength:	
Standard:	1310nm

CWDM: 1270nm-1610nm
ITU-T G.694.2 compliant

3.7. OPTICAL INPUT

Number of Inputs:
3505FR-32-BNC4: Up to 2 per SFP
3505FR-64-BNC2: Up to 2 per SFP
3505FR-DIN: Up to 2 per SFP
3505FR-XLINK: 2 per SFP
Connector: LC/UPC
Operating Wavelength: 1270nm to 1610nm
Maximum Input Power: -1dBm
Optical Sensitivity:
Standard: -21dBm at 2.97Gb/s pathological Level A
-23dBm at 2.97Gb/s color bars

3.8. ELECTRICAL INPUTS (3505FR-BNC & 3505FR-DIN ONLY)



NOTE: Electrical outputs specs only apply to reclocking SFP modules (3405T13-R & 3405OO13-DA4)

Reclocked Standard: SMPTE 424M (3Gb/s), SMPTE 292M (1.5Gb/s), SMPTE 259M (270Mb/s), DVB-ASI
Connector:
3505FR-32-BNC4: BNC per IEC 61169-8 Annex A
3505FR-64-BNC2: BNC per IEC 61169-8 Annex A
3505FR-DIN: DIN 1.0/2.3 Female connector
Equalization: Automatic to 80m @ 3Gb/s, 100m @ 1.5Gb/s, 250m @ 270Mb/s (with Belden 1694A or equivalent)
Return Loss: > 15dB up to 1.5GHz
> 10dB up to 3GHz

3.9. ELECTRICAL OUTPUTS (3505FR-BNC & 3505FR-DIN ONLY)



NOTE: Electrical outputs specs only apply to reclocking SFP modules (3405T13-R & 3405OO13-DA4)

Connector:
3505FR-32-BNC4: BNC per IEC 61169-8 Annex A
3505FR-64-BNC2: BNC per IEC 61169-8 Annex A
3505FR-DIN: DIN 1.0/2.3 Female connector
Impedance: 75 Ω (nominal)
Signal Level: 800mV (nominal)
DC Offset: 0V +/- 0.5V
Rise and Fall Time: < 135ps (HD/3G)

Overshoot:	< 900ps (SD)
Return Loss:	< 10% of amplitude > 15dB to 1.5GHz > 10dB to 3GHz
Alignment Jitter:	< 0.2UI (Reclocked) to 1.485Gb/s < 0.3UI (Reclocked) to 2.97Gb/s

3.10. PHYSICAL

Dimensions:	3.5"H x 19"W x 5.5"D
Module Capacity:	64 Evertz [®] 3405 or 3505 SFP modules
Operating Temperature:	0-40°C

3.11. ELECTRICAL

Power Supply Configuration:	Internal Removable Power Supplies (primary/secondary 3505PS)
AC Mains Input:	Auto-ranging, 100↔240VAC, 50/60Hz
Maximum Operating Current:	12.5A, 50A Max Inrush @ 25°C
Maximum Power Consumption:	150 W (fully loaded frame with all accessories) Note: Power consumption dependent on SFP type
Connector:	IEC 60320 – 1 per power supply
Status Indicators:	PST status LEDs (each per power supply tray)

3.12. COMPLIANCE

Safety:	CSA Listed to CSA C22.2 No. 60950-1:2007, UL 60950 2 nd Edition, IEC 60950-1:2006 incl. Am 11 Complies with CE Low voltage Directive 2004/108/EC
Laser Safety:	Class 1 laser product Complies with 21 CFR 1040.10 and 1040.11 except for deviations pursuant to Laser Notice No. 50, dated June 24, 2007, Complies with IEC 60825-1:2007 Edition 2
EMC:	Complies with FCC part 15, class A Complies with EU EMC directive 2006/95/EC
ROHS:	Complies with EU restriction on hazardous substances

2002/95/EC

This page left intentionally blank

4. STATUS AND LEDS

The 3505FC frame controller card is inserted through the front of the frame and is secured to the 3505FR frame with the one captive screws fastened on either side of the unit.

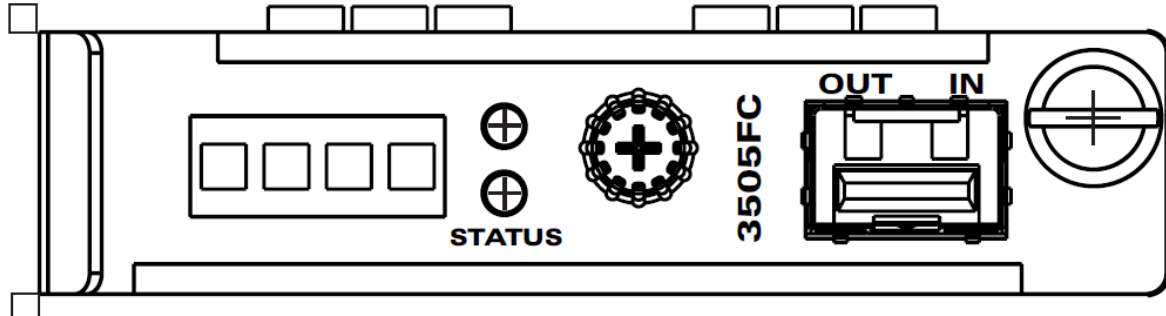

Figure 4-1: Front of 3505FC

4.1.1. STATUS LED

The two LEDs under the “STATUS” label on the front of the 3505FC identify the health of the frame and frame controller.

LED	Description
Red LED	<p>Red LED indicates failure of the power supply, fan or frame controller. The following parameters are monitored by the RED Status LED:</p> <ol style="list-style-type: none"> 3505 Power Supply unit (blown fuse, short circuit condition) Failure of the 3505FM Fan Module Failure of 3505FC or 3505FC-2
Green LED	<p>Green LED frame, frame controller and power supplies are all functioning normally.</p>

Table 4-1: Status LED Chart

4.1.2. SFP Monitoring LEDs

The 16 LEDs on the front of the 3505FC signify SFP module presence and signal status (1 through 16).

LED	Description
No LED	An unlit LED indicates that there is no SFP plugged into the associated port number.
Red LED	Red LEDs indicate the presence of an error with the particular SFP inserted in the corresponding port number, or it indicates a loss of signal (fiber or coax). A Red LED indicates that the SFP is Present, but there are errors on the input signal and an input has been unplugged from the SFP.
Green LED	Green LEDs indicate the presence of a working SFP module corresponding to the SFP port number. A Green LED indicates that the SFP is Present, there is a valid signal input, and both inputs are plugged into the SFP. Note: Both fiber inputs (for receiver) or both coax inputs (for transmitter) will need to be connected to the SFP in order for the LED to go Green.

Table 4-2: SFP LED Chart

A backup 3505FC frame controller module can optionally be installed in the frame in the same manner as the primary 3505FC.



Note: The Redundancy of the frame controller is currently not supported.

5. CONFIGURATION AND CONTROL

The 3505FR series frames are capable of supporting two (main and redundant) 3505FC Frame Controller cards to provide a single point of access to communicate with the VistaLINK[®] enabled 3505FR. Each 3505FC provides a 10Base-T/100Base-TX Ethernet port and communication is facilitated through the use of Simple Network Management Protocol (SNMP). The 3505FC handles all SNMP communications between the frame (3505FR) and the network manager (NMS), and serves as a gateway to individual SFP's in the frame. A custom serial cable (Evertz part number: WP-DB9M-2XDB9F-6FT) is included with each 3505FR frame and is required to configure main and redundant 3505FC. When not in use, store the serial cable in a safe place as it may be needed in the future.

5.1. 3505 FRAME CONTROLLER CONFIGURATION

This step by step guide will allow the user to change the Ethernet settings for SNMP communications.

- 1) Connect DB9M end of the cable to the port labeled SERIAL COM on the rear side of the 3505FR frame. Connect DB9F1 end of cable to HyperTerminal for configuration of FC1. Connect DB9F2 end of the cable to HyperTerminal for configuration of FC2.
- 2) Use the following COM Port Settings to properly communicate with the 3505FC:
 - a. Baud: 115200
 - b. Data: 8 bit
 - c. Parity: none
 - d. Stop Bits: 2
 - e. Flow Control: none
- 3) Login to the configuration menu using user name "customer"
- 4) Modify network parameters by entering the (2) Network Settings menu. The following Network Parameters are available for modification:
 - (1) IP Address *[Displays current IP Address]*
 - (2) Netmask *[Displays current Netmask Address]*
 - (3) Gateway *[Displays current Gateway Address]*
 - (4) Broadcast *[Displays current Broadcast Address]*
- 5) Modify SNMP Settings by entering the (3) SNMP Settings menu. The following SNMP parameters are available for modification:
 - (1) Select SNMP v1/v3 *[Displays current SNMP version]*
 - (2) SNMPv1 Settings *[Enter to modify SNMPv1 Settings]*
 - (3) SNMPv3 Settings *[Enter to modify SNMPv3 Settings]*
 - (4) Trap Setup *[Enter to modify Trap Destinations]*

5.2. VISTALINK® CONFIGURATION



NOTE: The screenshots throughout sections 5.2.1 to 5.2.3 illustrate VistaLINK® parameters for the following SFP types: 3405T13-2, 3405T13-R, 3405R-2, 3405R-2R, and 3405OO13-DA4.

5.2.1. General Tab

The **General** tab enables the user to view the status of various parameters such as SFP *Type*, *Serial Number*, and *SFP Firmware Version*.

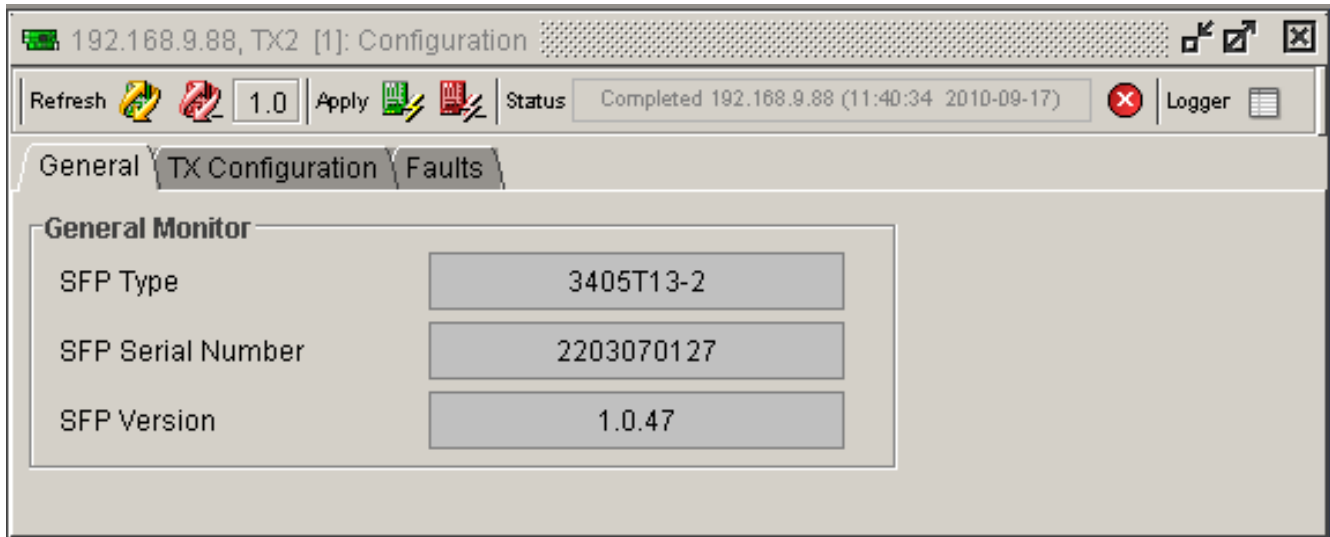

Figure 5-1: 3405T13-2 VistaLINK® General Tab

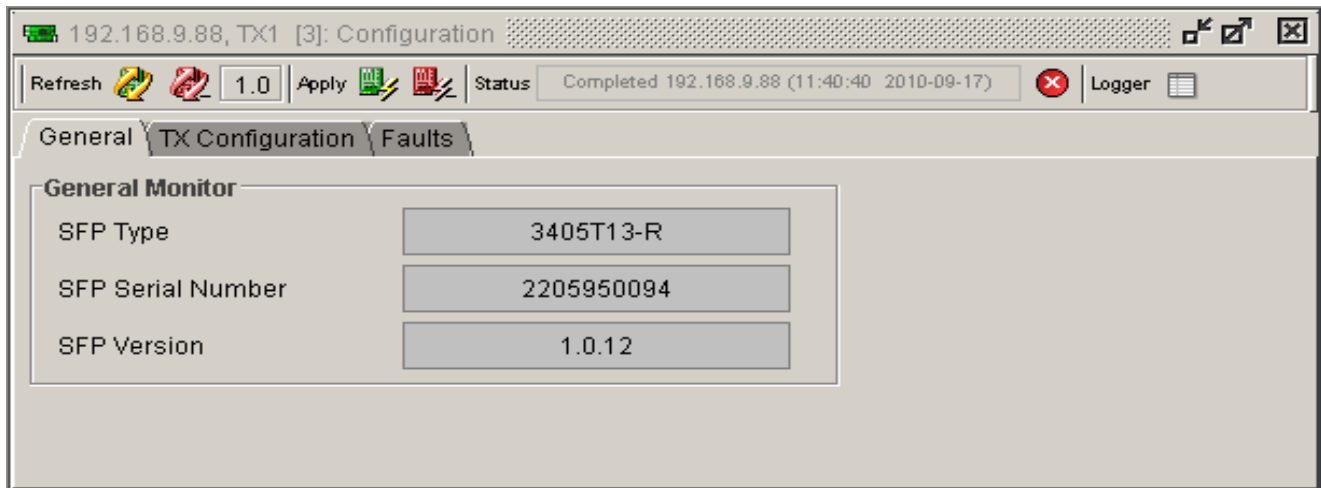

Figure 5-2: 3405T13-R VistaLINK® General Tab

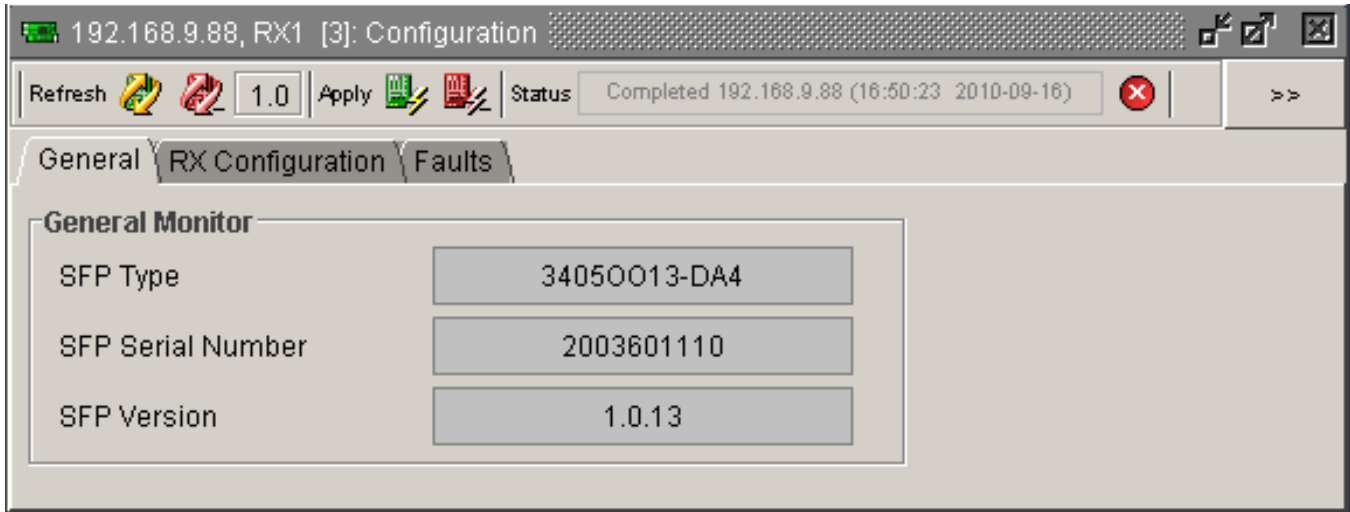

Figure 5-3: 34050013-DA4 VistaLINK® General Tab

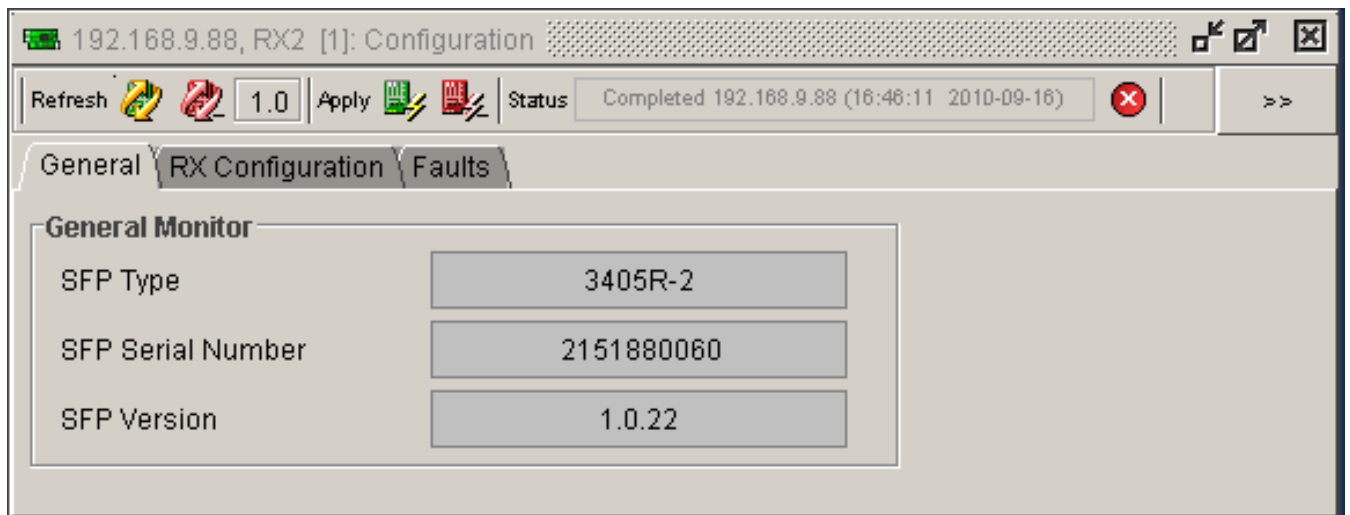

Figure 5-4: 3405R-2 VistaLINK® General Tab

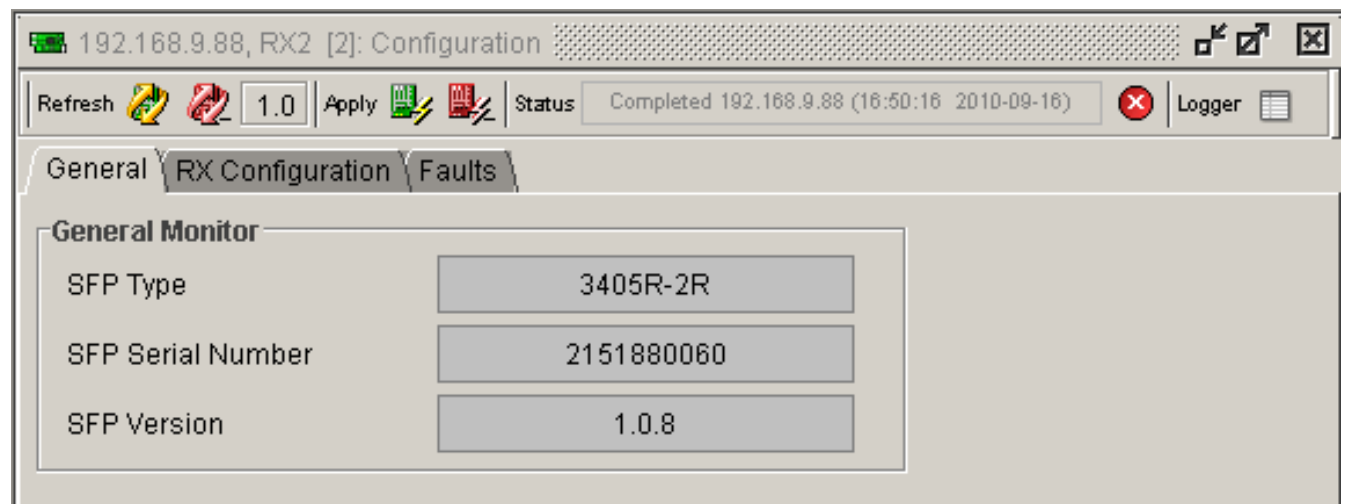

Figure 5-5: 3405R-2R VistaLINK® General Tab

- **SFP Type:** Displays the type of SFP plugged into a particular slot.
- **SFP Serial Number:** Displays the SFP serial number.
- **SFP Version:** Displays the current SFP version number.

5.2.2. TX/RX Configuration Tabs

The **TX Configuration** tab displays the current *Laser Status*, *Wavelength*, *SFP Status*, and *Reclocker Status*. It also allows the user to set *Squelch mode*.

The **RX Configuration** tab displays the *Received Optical Power* and *Reclocker Status*. It also allows the user to set *Optical Input Power Threshold*, *Inversion mode*, *Slew Rate mode*, *Squelch Mode*, and *Swap Channel mode*.

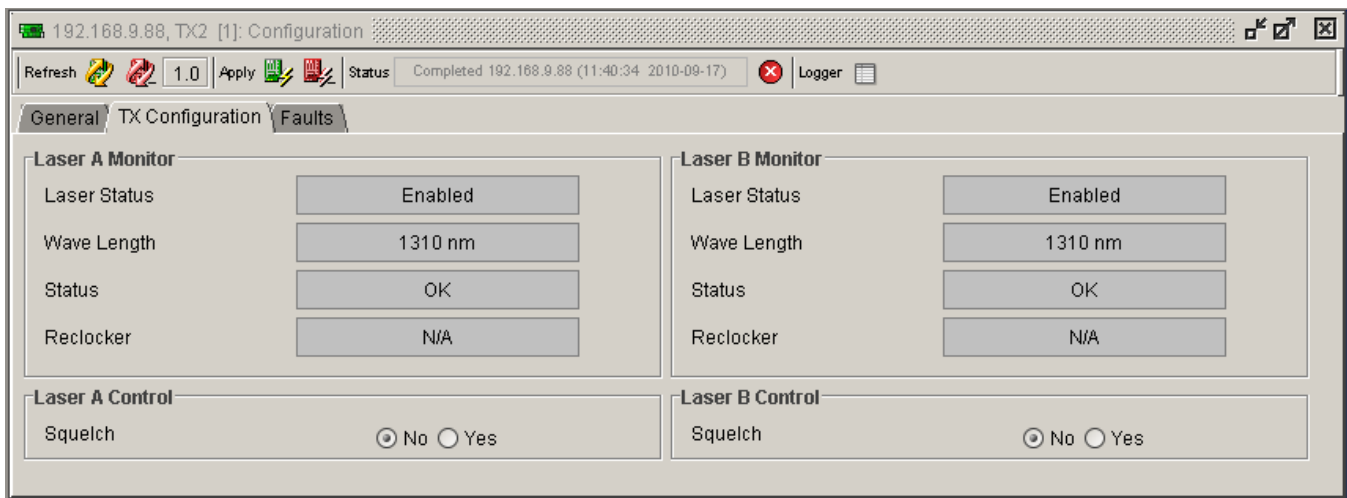

Figure 5-6: 3405T13-2 VistaLINK® TX Configuration Tab

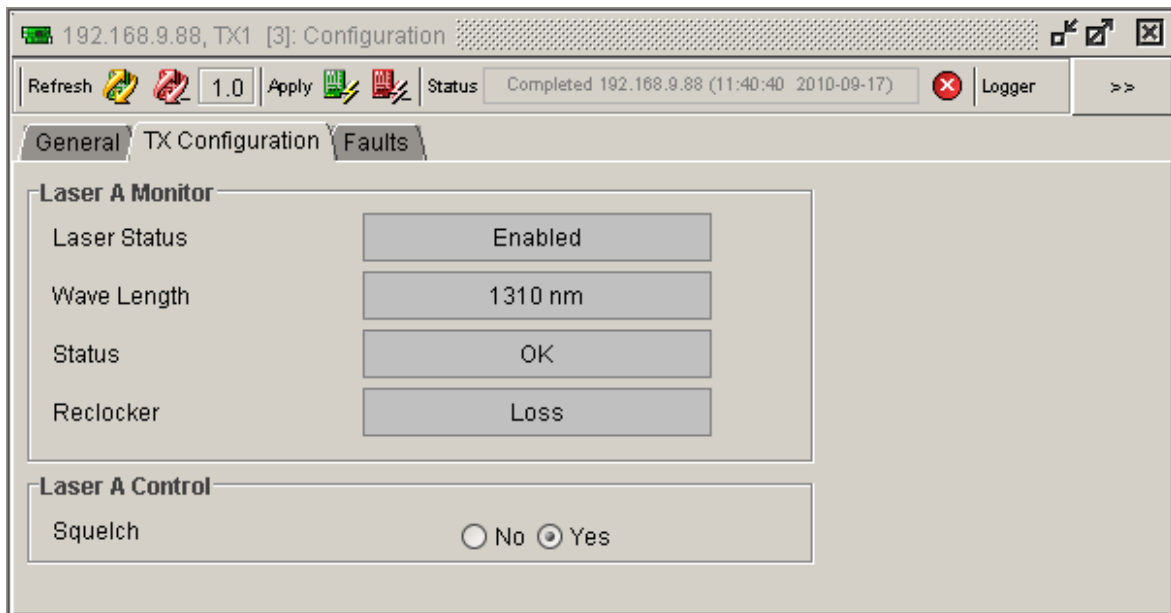

Figure 5-7: 3405T13-R VistaLINK® TX Configuration Tab

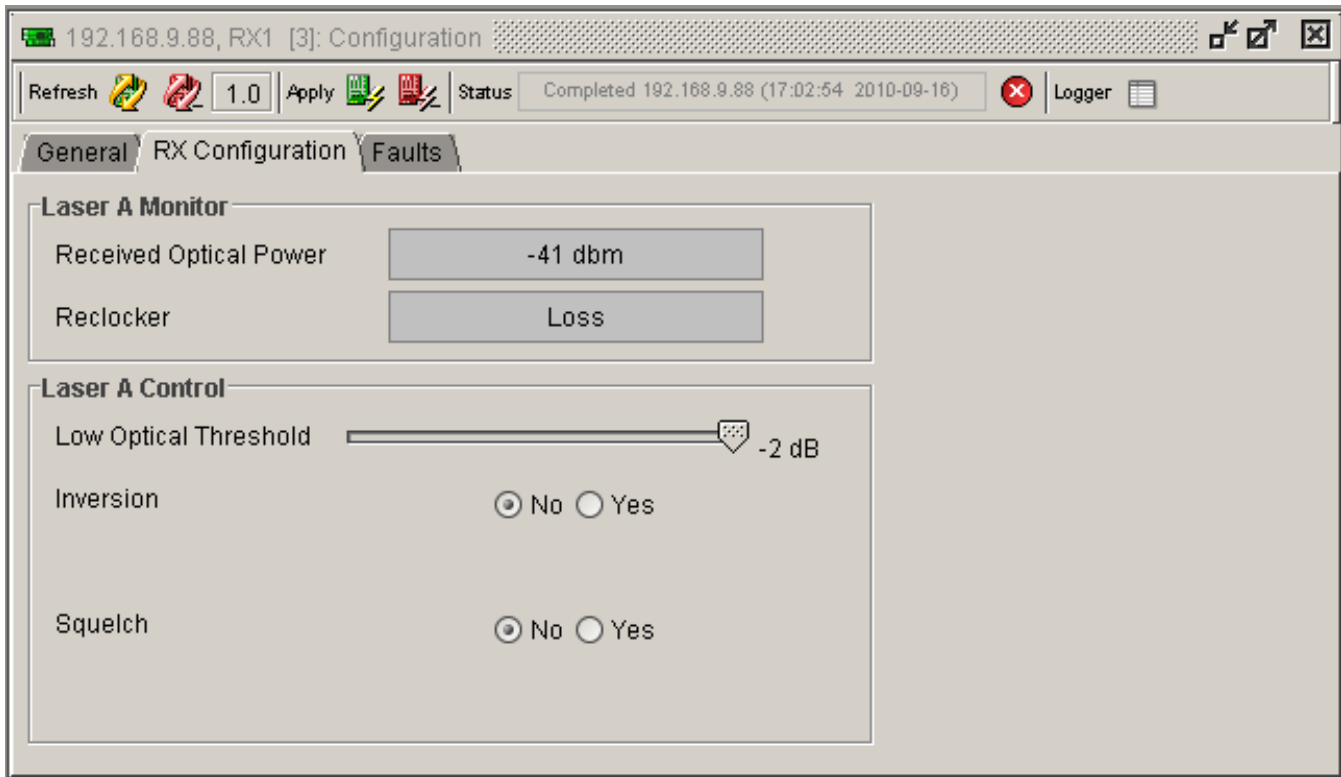

Figure 5-8: 3405OO13-DA4 VistaLINK® RX Configuration Tab

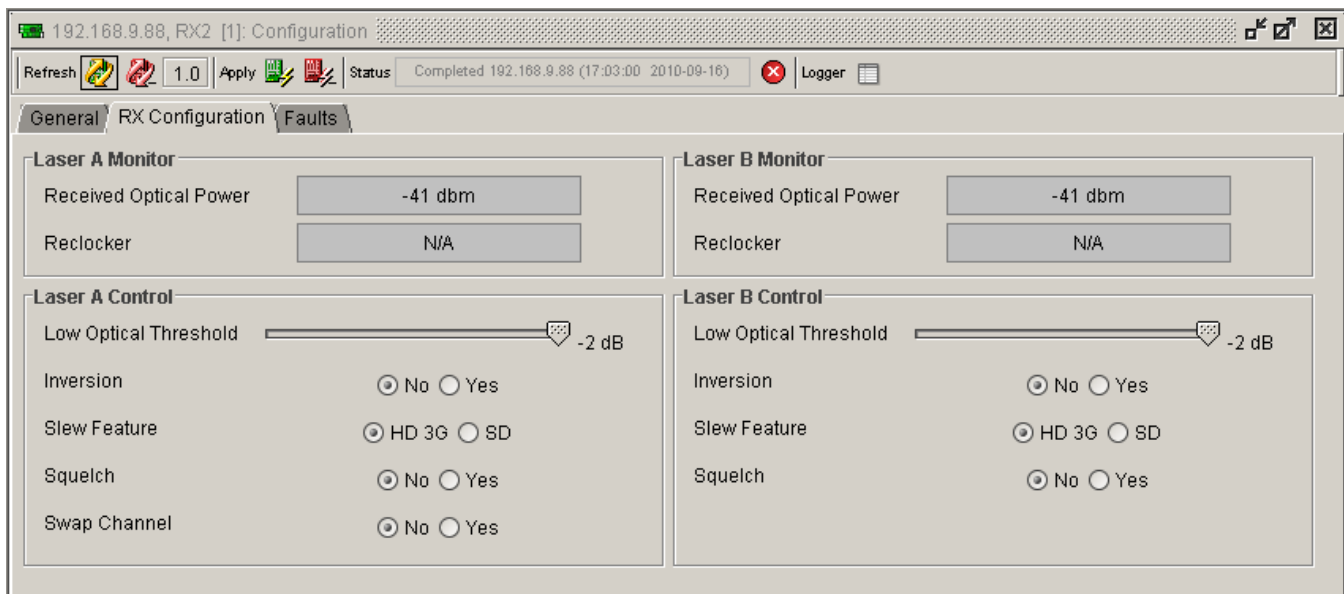

Figure 5-9: 3405R-2 VistaLINK® RX Configuration Tab

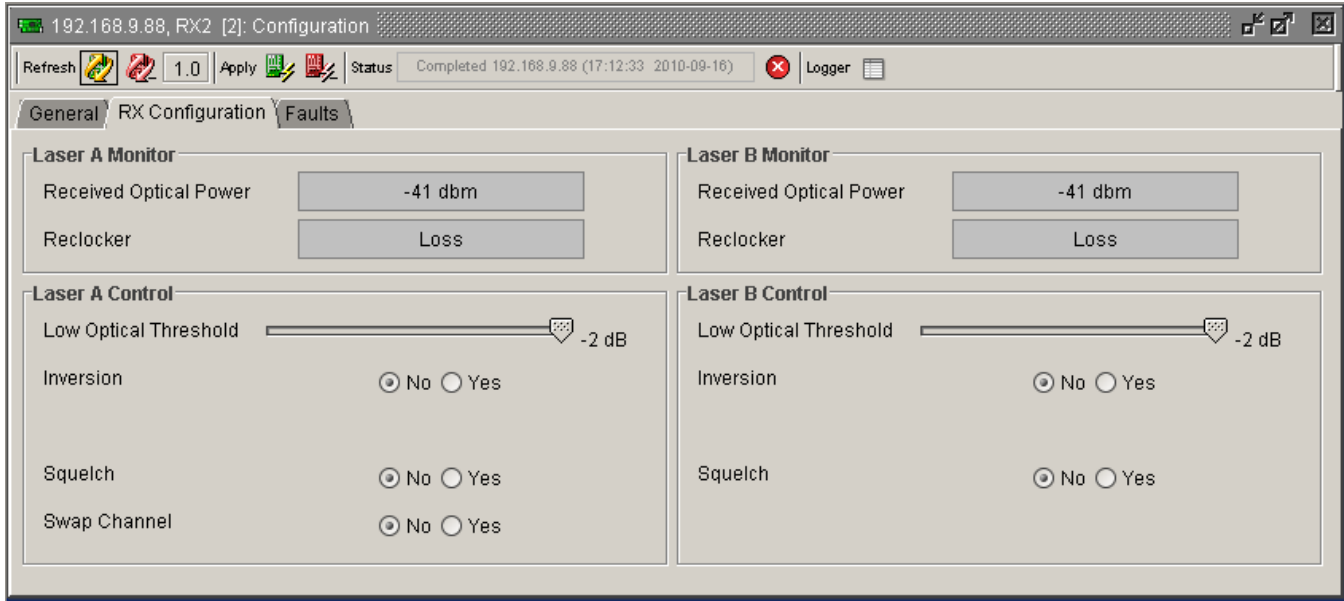

Figure 5-10: 3405R-2R VistaLINK® RX Configuration Tab

5.2.2.1. Tx Configuration

- **Laser Status:** Displays the status of the laser in a SFP transmitter module.
- **Wavelength:** Displays the wavelength of the SFP transmitter.
- **Status:** Displays the general health of the SFP.
- **Reclocker:** Displays Reclocking Standard if applicable.
- **Squelch:** Sets Squelch Mode.

5.2.2.2. Rx Configuration

- **Received Optical Power:** Displays the optical input power of a SFP receiver.
- **Reclocker:** Displays Reclocking Standard if applicable
- **Low Optical Threshold:** Sets Low Optical Threshold value
- **Inversion:** Sets output inversion mode
- **Slew Feature:** Sets output Slew rate mode
- **Squelch:** Sets output squelch mode
- **Swap Channel:** Sets output mapping mode

5.2.3. Faults Tab

The **Faults** tab allows the user to enable a variety of traps. To enable a particular trap, simply click the box adjacent to each trap so that a check-mark appears. When a check-mark is present, the trap is enabled. When a check-mark is not present, the trap is disabled.

The *Trap Status* section defines whether a trap is present or missing. If the box is green, then the corresponding trap is present. If the box is red, then the corresponding trap is missing.

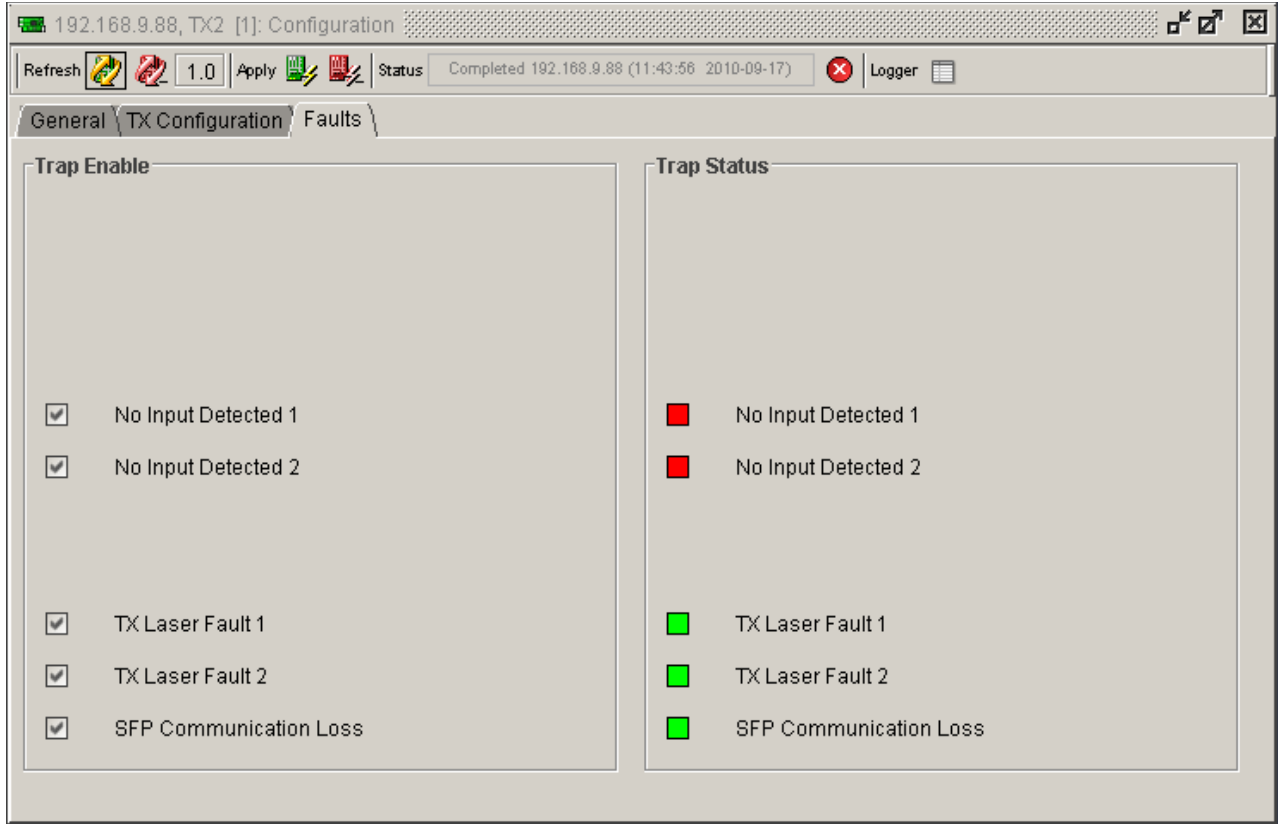

Figure 5-11: 3405T13-2 VistaLINK® Faults Tab

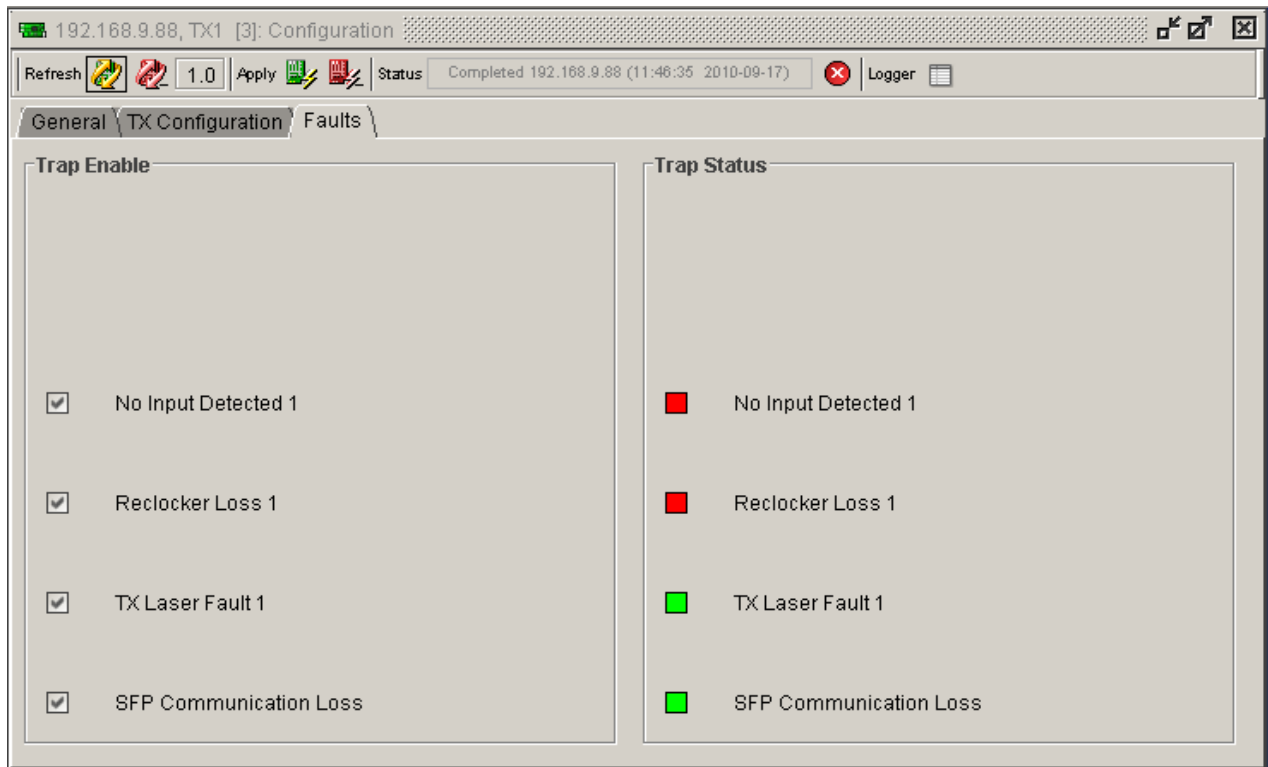

Figure 5-12: 3405T13-R VistaLINK® Faults Tab

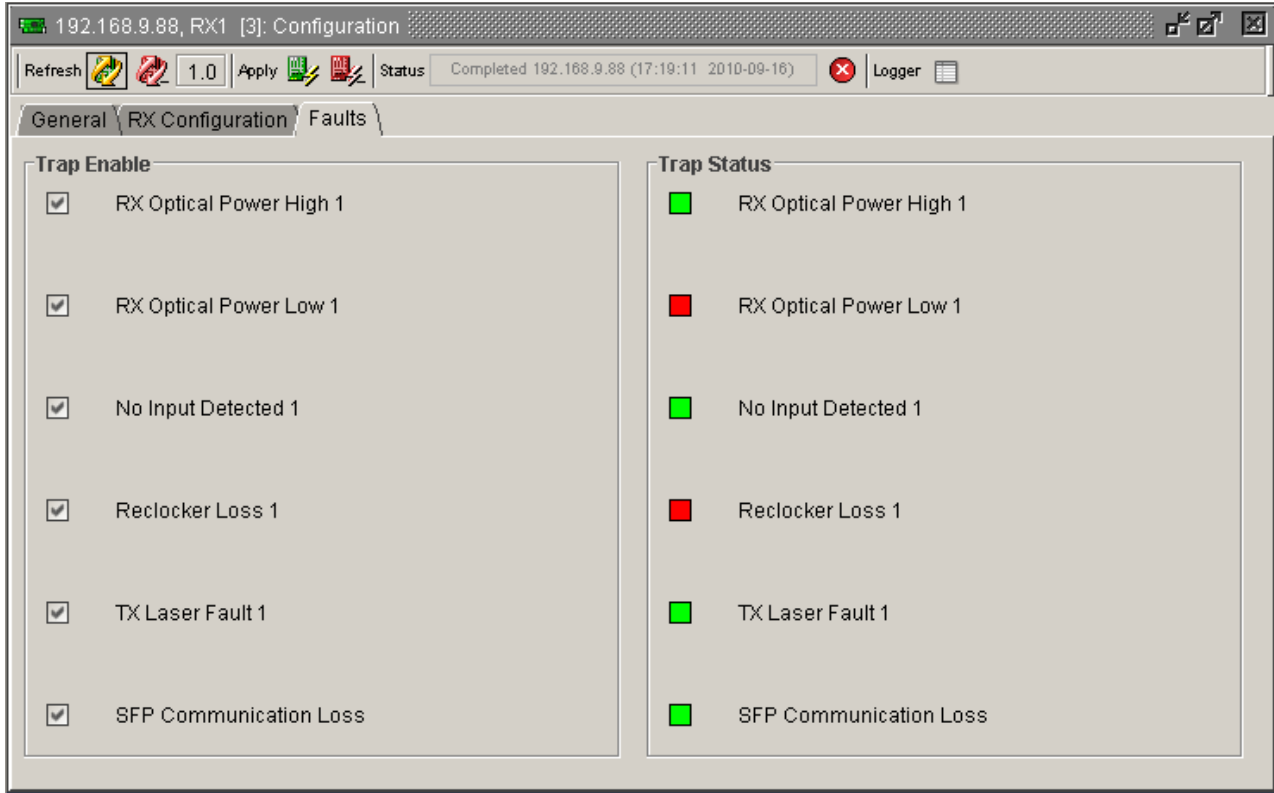

Figure 5-13: 3405OO13-DA4 VistaLINK® Faults Tab

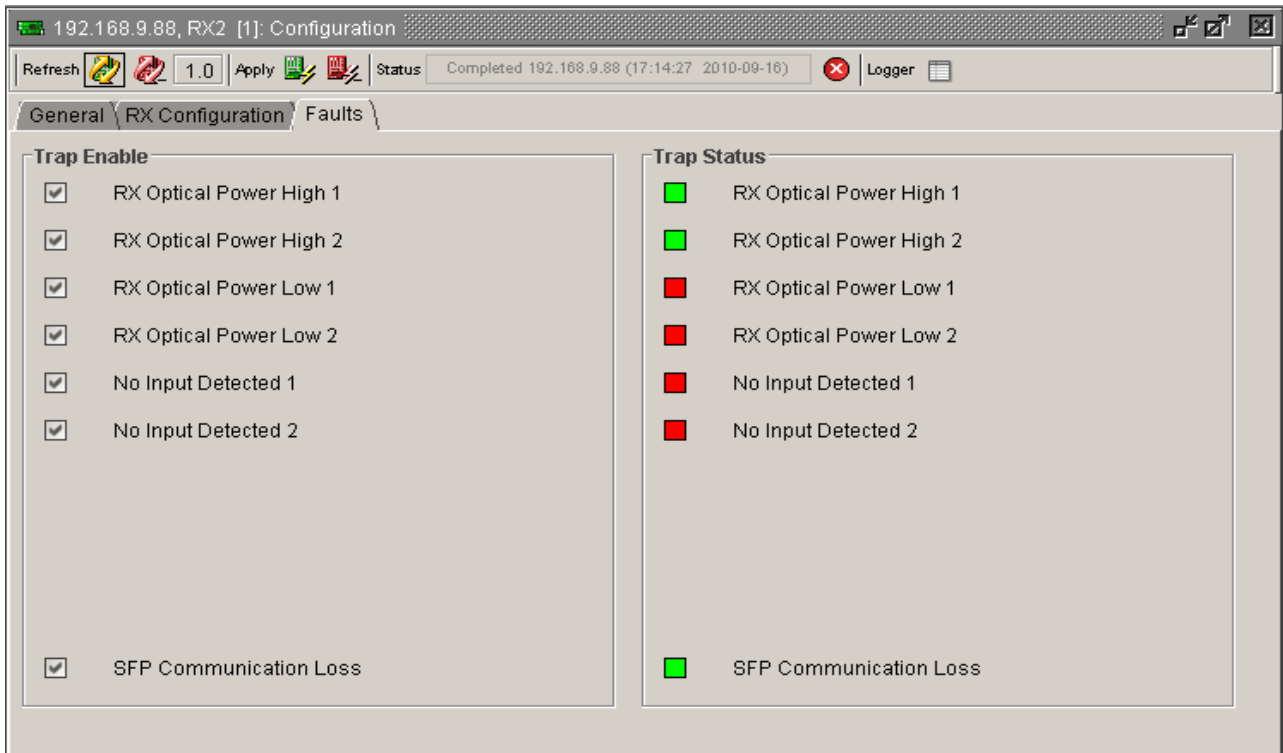

Figure 5-14: 3405R-2 VistaLINK® Faults Tab

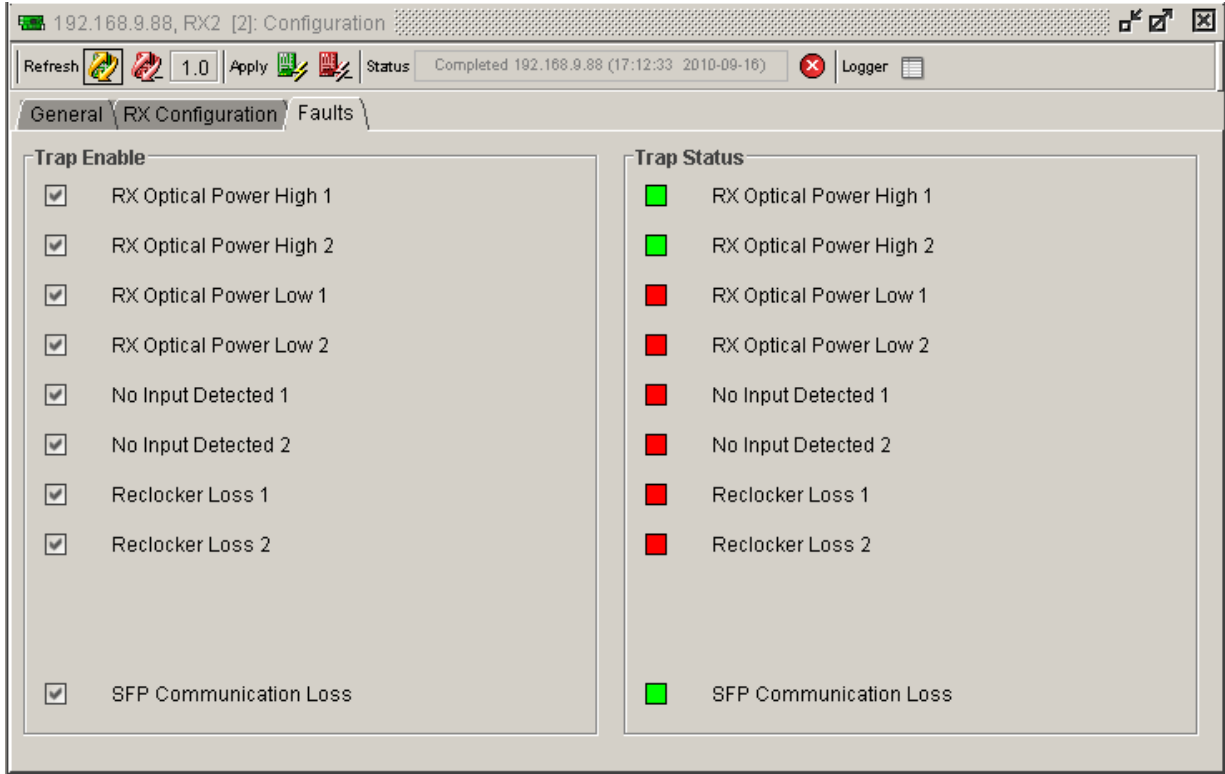

Figure 5-15: 3405R-2R VistaLINK® Faults Tab



NOTE: The screenshots throughout sections 0 and 5.2.6 illustrate VistaLINK® parameters for the 3505FC Frame Controller.

5.2.4. Network Parameters Tab

The **Network** parameter tab enables the user to define the network parameters of the 3505FC. IP Address, Subnet Mask, Gateway Address, and Broadcast Address can be modified. Under this tab, there is also an option to reboot the frame.

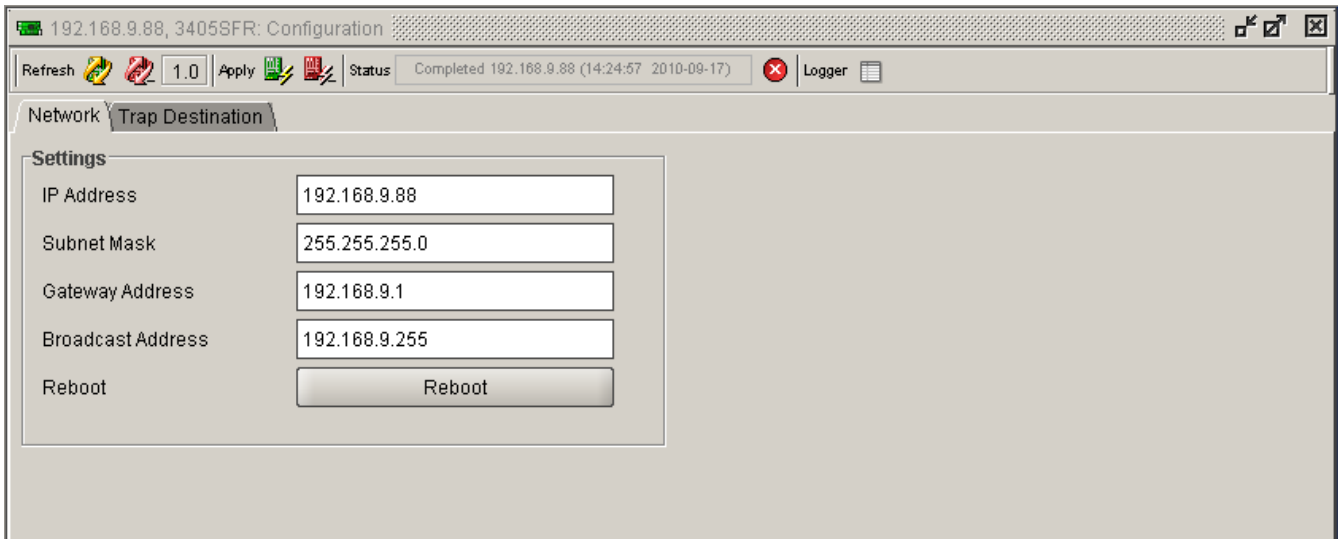

Figure 5-16: 3505FC VistaLINK® Network Parameter Tab

5.2.5. Trap Destination Tab

The **Trap Destination** tab enables the user to define the IP address where SNMP traps will be sent.

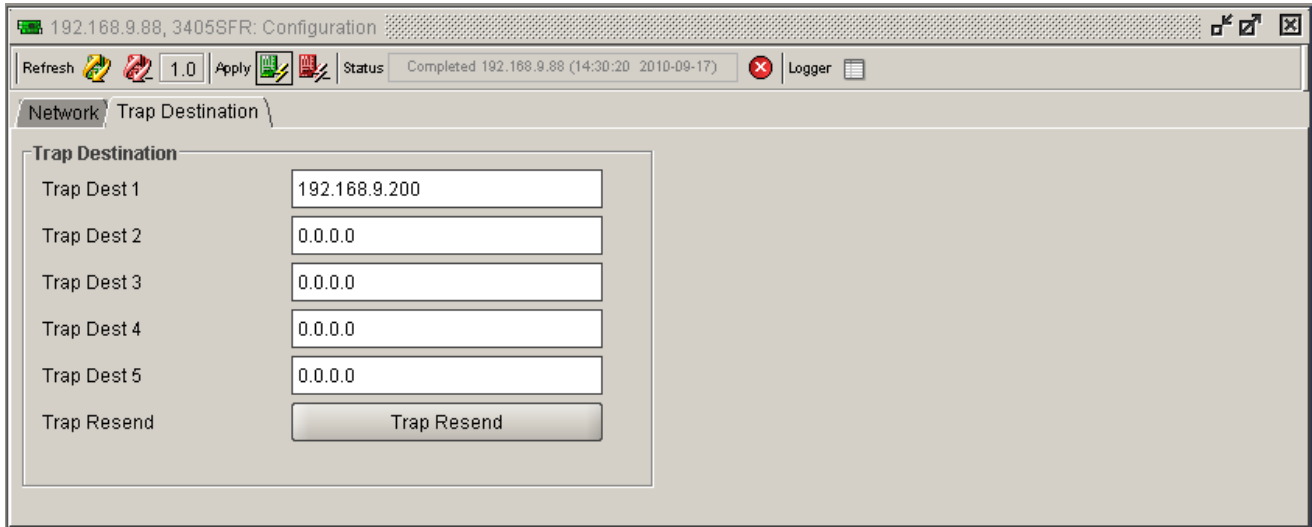

Figure 5-17: 3505FC VistaLINK® Trap Destination Tab

- **Trap Resend:** Select this button to resend the current trap state of the card. All existing traps occurring on the card will be re-broadcast to the VistaLINK® SNMP Client and can be viewed in the trap log.

5.2.6. FC Faults Tab

The **FC Faults** tab allows the user to enable a variety of traps. To enable a particular trap, simply click the box located beside each trap so that a check-mark appears. When a check-mark is present, the trap is enabled. When a check-mark is not present, the trap is disabled.

The *Trap Status* section defines whether a trap is present or missing. If the box is green, then the corresponding trap is present. If the box is red, then the corresponding trap is missing.

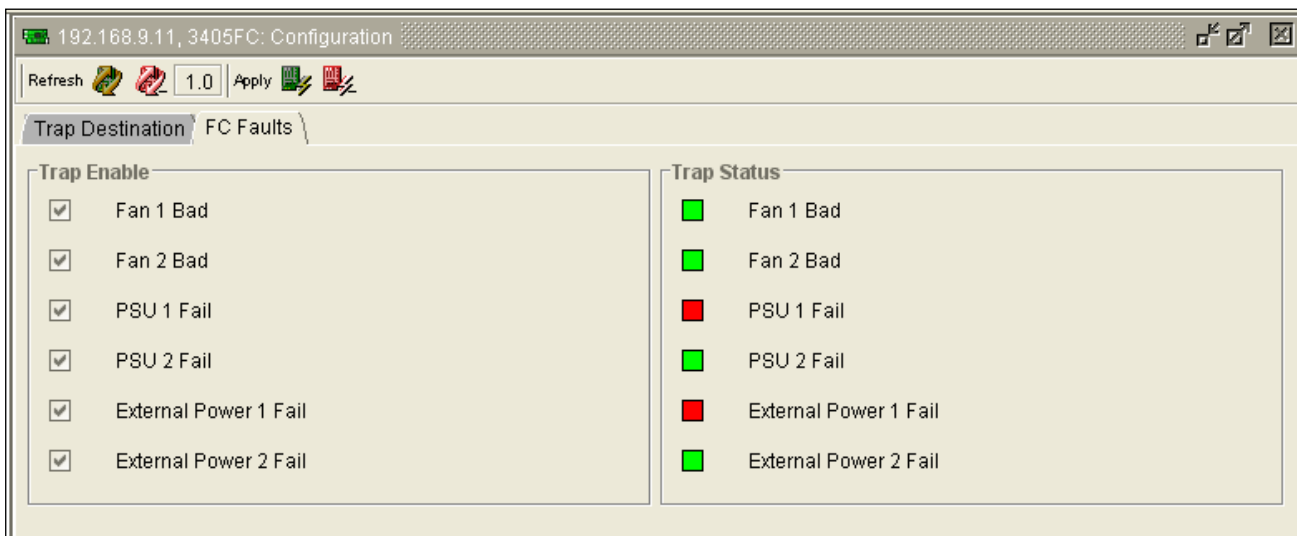

Figure 5-18: 3505FC VistaLINK® FC Faults Tab

6. VISTALINK[®] MONITORING/CONTROL

6.1. WHAT IS VISTALINK[®]?

VistaLINK[®] is Evertz's remote monitoring and configuration platform which operates over an Ethernet network using Simple Network Management Protocol (SNMP). SNMP is a standard computer network protocol that enables different devices sharing the same network to communicate with each other. VistaLINK[®] provides centralized alarm management, which monitors, reports, and logs all incoming alarm events and dispatches alerts to all the VLPro Clients connected to the server. Card configuration through VistaLINK[®] PRO can be performed on an individual or multi-card basis using simple copy and paste routines, which reduces the time to configure each module separately. Finally, VistaLINK[®] enables the user to configure devices in the network from a central station and receive feedback that the configuration has been carried out.

An SNMP manager, also known as a Network Management System (NMS), is a computer running special software that communicates with the devices in the network. Evertz VistaLINK[®] Pro Manager graphical user interface (GUI), third party or custom manager software may be used to monitor and control Evertz VistaLINK[®] enabled products.

6.2. VISTALINK[®] MONITORED PARAMETERS

The following parameters can be monitored via the VistaLINK[®] interface.

Parameter	Description
SFP Type	Monitors the type of SFP plugged into a particular slot (TX/RX/OO).
SFP Serial Number	Monitors the SFP serial number.
SFP Version	Monitors the SFP code version.
Received Optical Power	Detects optical input power into each individual SFP receiver.
Reclocker	Detects the reclocking rate of an incoming signal.
Laser Status	Monitors the health of the laser in a SFP transmitter module.
Laser Wavelength	Monitors the wavelength of the SFP transmitter.
Status	Monitors the general health of the SFP

Table 6-1: VistaLINK[®] Monitoring

6.3. VISTALINK® TRAPS

The following traps can be enabled and monitored through the VistaLINK® interface.

Parameter	Description
Rx Optical Power High 1	Monitors high optical input on channel 1
Rx Optical Power High 2	Monitors high optical input on channel 2
Rx Optical Power Low 1	Monitors low optical input on channel 1
Rx Optical Power Low 2	Monitors low optical input on channel 2
No Input Detected 1	Monitors video input on channel 1
No Input Detected 2	Monitors video input on channel 2
Reclocker Loss 1	Monitors reclocking status on channel 1
Reclocker Loss 2	Monitors reclocking status on channel 2
Tx Laser Fault 1	Monitors laser 1 health
Tx Laser Fault 2	Monitors laser 2 health
SFP Communication Loss	Monitors SFP communication with frame controller
Fan Bad	Monitors health of fan #1 of 3505FM unit
PSU 1 Fail	Monitors health of upper 3505PS unit
PSU 2 Fail	Monitors health of lower 3505PS unit
External Power 1 Fail	Monitors the presence of AC power to DC inlet #1
External Power 2 Fail	Monitors the presence of AC power to DC inlet #2

Table 6-2: VistaLINK® Traps

6.4. VISTALINK® CONTROLLED PARAMETERS

The following parameters can be controlled via the VistaLINK® interface.

Parameter	Description
IP Address	Sets IP Address.
Subnet Mask	Sets Subnet Mask.
Gateway Address	Sets Gateway Address.
Broadcast Address	Sets Broadcast Address.
Reboot	Reboots the 3505FR frame.
Frame Controller Trap Destination	Defines the IP address where SNMP traps will be sent to.
Trap Resend	Resends the current traps state.
Low Optical Threshold	Sets the Input Optical Power Threshold.
Inversion	Sets the Inversion.
Squelch	Sets the Output Squelch mode.
Swap Channel	Sets the Channel Swap mode.
Slew Feature	Sets the Output Slew rate.

Table 6-3: VistaLINK® Controlled Parameters