

**TABLE OF CONTENTS**

<b>1. OVERVIEW.....</b>	<b>1</b>
<b>2. INSTALLATION.....</b>	<b>3</b>
<b>3. SPECIFICATIONS.....</b>	<b>4</b>
<b>3.1. AES AUDIO INPUTS .....</b>	<b>4</b>
<b>3.2. AES AUDIO OUTPUTS .....</b>	<b>4</b>
<b>3.3. ELECTRICAL .....</b>	<b>4</b>
<b>3.4. PHYSICAL .....</b>	<b>4</b>
<b>4. STATUS LEADS .....</b>	<b>5</b>
<b>5. JUMPERS AND USER ADJUSTMENTS .....</b>	<b>6</b>
<b>5.1. INPUT TERMINATION JUMPER .....</b>	<b>6</b>
<b>5.2. SELECTING WHETHER LOCAL FAULTS WILL BE MONITORED         BY THE GLOBAL FRAME STATUS.....</b>	<b>7</b>

**Figures**

Figure 1-1: 500DA-AESU Block Diagram .....	1
Figure 1-2: 500DA-AESU Block Diagram Installed in 500FR-L-A-Frame.....	2
Figure 2-1: 500DA-AESU Rear Panel Overlay .....	3
Figure 5-1: LED and Jumper Locations .....	6

## REVISION HISTORY

<u>REVISION</u>	<u>DESCRIPTION</u>	<u>DATE</u>
1.0	Original Version	Oct 02
1.1	Updated Block Diagram, LED and Jumper information	Mar 03
1.2	Information added to support looping within a 500FR-L-A frame	Mar 07
1.3	Fixed formatting and typos	Jul 07

Information contained in this manual is believed to be accurate and reliable. However, Evertz assumes no responsibility for the use thereof nor for the rights of third parties, which may be effected in any way by the use thereof. Any representations in this document concerning performance of Evertz products are for informational use only and are not warranties of future performance, either express or implied. The only warranty offered by Evertz in relation to this product is the Evertz standard limited warranty, stated in the sales contract or order confirmation form.

Although every attempt has been made to accurately describe the features, installation and operation of this product in this manual, no warranty is granted nor liability assumed in relation to any errors or omissions unless specifically undertaken in the Evertz sales contract or order confirmation. Information contained in this manual is periodically updated and changes will be incorporated into subsequent editions. If you encounter an error, please notify Evertz Customer Service department. Evertz reserves the right, without notice or liability, to make changes in equipment design or specifications.

## 1. OVERVIEW

The 500DA-AESU provides an economical method of distribution for your AES digital audio signals. The DA's feature one auto-equalized input with nine re-clocked outputs.

The 500DA-AESU is housed in the 500FR **exponent** Frame, which will hold up to 16 modules.

The 500DA-AESU can also be installed and used within the 500FR-L-A exponent Frame with Loop Thru. When used with this frame the 500DA-AESU will become a 1x8 AES distribution amplifier with passive Loop Thru.

### Features:

- Supports SMPTE 276M standard for AES audio on 75  $\Omega$  coax
- 9 reclocked outputs provide jitter reduction
- Automatic equalization provides extended cable length capabilities
- High impedance or 75  $\Omega$  termination on input (jumper selectable)
- Card edge indicators for AES present, reclocker rate and AES validity bit
- Tally output of input error conditions

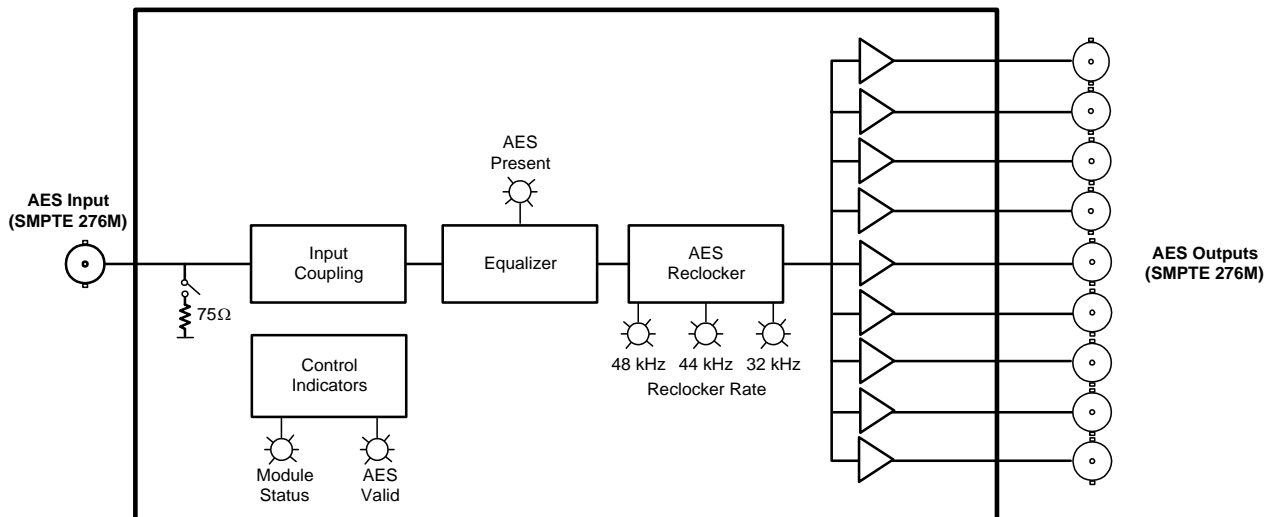
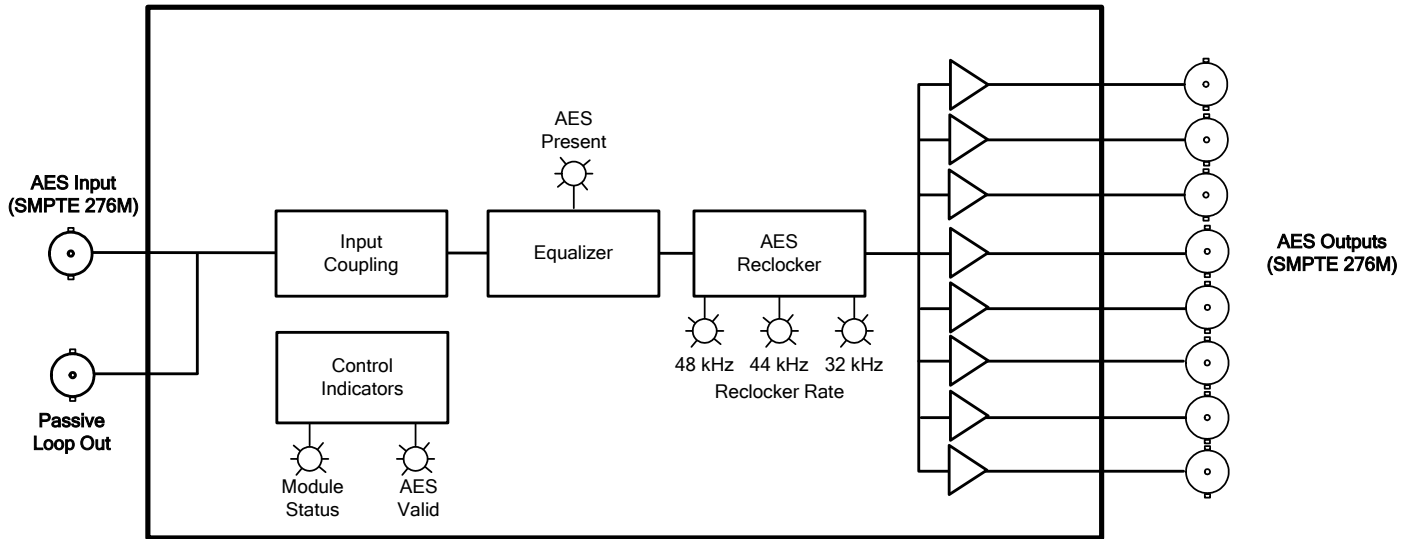

Figure 1-1: 500DA-AESU Block Diagram



**Figure 1-2: 500DA-AESU Block Diagram Installed in 500FR-L-A-Frame**

## 2. INSTALLATION

The 500DA-AESU comes with a companion rear panel overlay that can be placed over the rear panel BNC connectors to identify their function. For information on inserting the module into the frame see section 3 of the 500FR chapter.

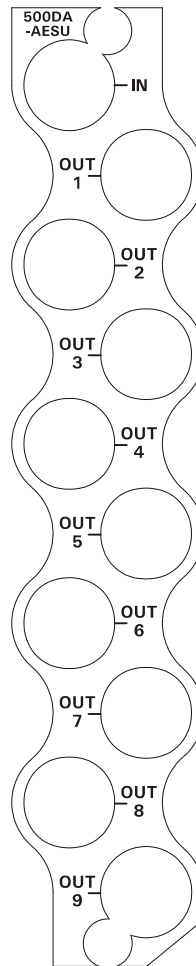

**Figure 2-1: 500DA-AESU Rear Panel Overlay**

**IN** Input BNC connector for unbalanced AES audio signals compatible with the SMPTE 276M standard.

**OUT 1 to 9** There are nine BNC connectors with reclocked unbalanced AES, which are compatible with the SMPTE 276M.



**When installed within a 500FR-L-A frame, OUT 1 becomes a passive looping output. Outputs 2 to 9 provide eight BNC connectors with reclocked unbalanced AES outputs, which are compatible with SMPTE 276.**

---

### 3. SPECIFICATIONS

#### 3.1. AES AUDIO INPUTS

<b>Number of Inputs:</b>	1
<b>Standard:</b>	SMPTE 276M, single ended AES
<b>Connectors:</b>	BNC per IEC 169-8
<b>Coupling:</b>	Transformer
<b>Signal Level:</b>	1V p-p $\pm$ 0.1V
<b>Equalization:</b>	Automatic to 1500m @48KHz with Belden 1694A or equivalent cable
<b>Impedance:</b>	75 $\Omega$
<b>Return Loss:</b>	>25 dB 100 kHz to 6 MHz
<b>Sampling Rate:</b>	32 kHz, 44.1 kHz, 48 kHz and 96 kHz

#### 3.2. AES AUDIO OUTPUTS

<b>Number of Outputs:</b>	9 reclocked
<b>Standard:</b>	SMPTE 276M, single ended AES
<b>Connectors:</b>	BNC per IEC 169-8
<b>Signal Level:</b>	1V p-p $\pm$ 0.1V
<b>Impedance:</b>	75 $\Omega$ unbalanced
<b>Return Loss:</b>	>25 dB 100 kHz to 6 MHz

#### 3.3. ELECTRICAL

<b>Voltage:</b>	+ 12VDC
<b>Power:</b>	5 Watts.

#### 3.4. PHYSICAL

<b>Number of slots:</b>	1
-------------------------	---

## 4. STATUS LEDs

The 500DA-AESU has seven LED Status indicators on the front card edge to show operational status of the card at a glance. Figure 5-1 displays the location of the LEDs.

Two large LEDs on the front of the board indicate the general health of the module:

**LOCAL FAULT:** This Red LED indicates poor module health and will be On during the absence of a valid input signal, or if a local input power fault exists (i.e.: a blown fuse). The LOCAL FAULT indication can also be reported to the frame through the FRAME STATUS jumper.

**MODULE OK:** This Green LED indicates good module health. It will be On when a valid input signal is present and the board power is good.

There are five small LEDs that indicate the status of the input AES audio.

**AES PRESENT:** This LED will be On when there is an AES carrier present at the input to the module.

**48 kHz:** The reclocker is currently locked to 48 kHz.

**44 kHz:** The reclocker is currently locked to 44.1 kHz.

**32 kHz:** The reclocker is currently locked to 32 kHz.

**AES VBIT** This LED indicates the status of the AES validity bit. When the LED is Off it indicates that the AES sample data is suitable for conversion to an analog audio signal. When the LED is On it indicates that the AES sample data is carrying data such as Dolby E and is not suitable for conversion to an analog audio signal.

## 5. JUMPERS AND USER ADJUSTMENTS

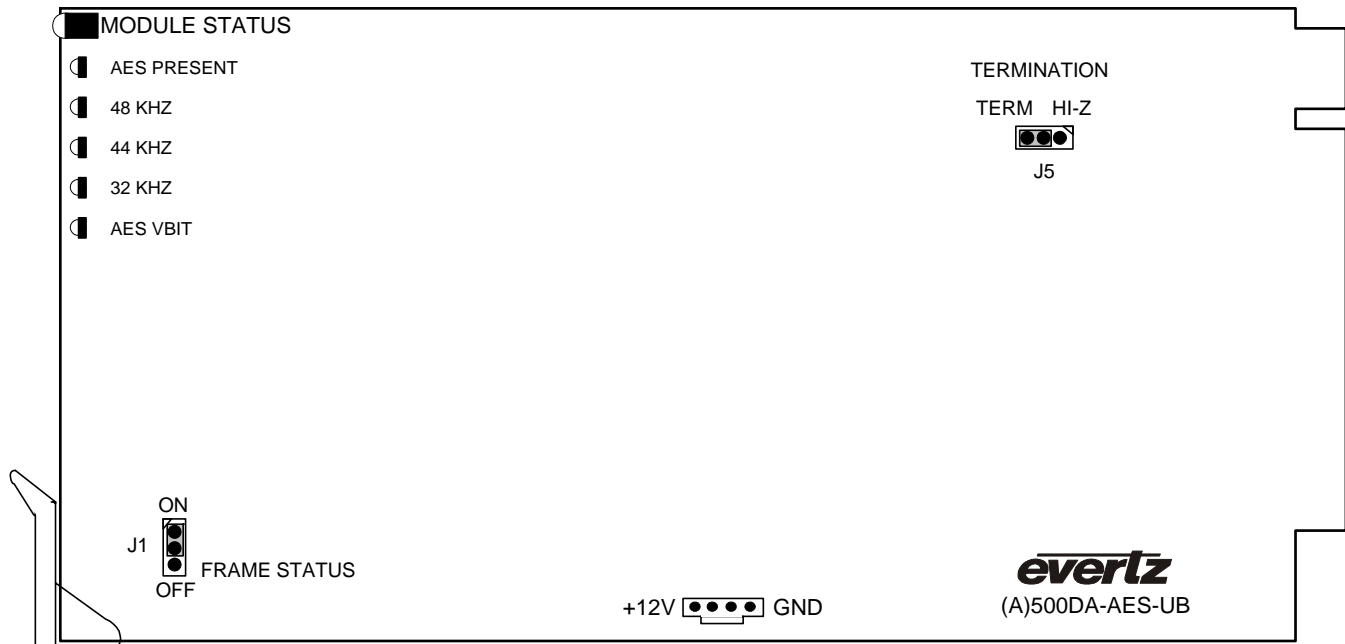

Figure 5-1: LED and Jumper Locations

### 5.1. INPUT TERMINATION JUMPER

The TERMINATION jumper J5, located at the rear of the module, determines whether the input signal will be terminated or not.

#### TERMINATION

When set in the "TERM" position, (default) the input impedance is set to 75 Ohms. Use this position when the cable stops at this card. It will provide the proper impedance to eliminate electrical reflections.

If set to "UNTERM", the input will be high impedance. Use this position when the signal does NOT stop at this card. Install a "T" connector on the INPUT BNC to "loop" the signal through this card. The "T" connector is not required when installing the 500DA-AESU module within a 500FR-L-A frame.



**WARNING: Make sure that the final destination of the signal is terminated. Otherwise, reflections will occur affecting the signal throughout the cable.**



## 5.2. SELECTING WHETHER LOCAL FAULTS WILL BE MONITORED BY THE GLOBAL FRAME STATUS

The FRAME STATUS jumper J1, located at the front of the module, determines whether local faults (as shown by the Local Fault indicator) will be connected to the 500FR frame's global status bus.

**FRAME STATUS:** To monitor faults on this module with the frame status indicators (on the power supply's FRAME STATUS LED's and on the Frame's Fault Tally output) install this jumper in the On position.

When this jumper is installed in the Off position local faults on this module will not be monitored.

*This page left intentionally blank*