

---

---

## TABLE OF CONTENTS

1.	OVERVIEW.....	1
2.	INSTALLATION.....	2
3.	SPECIFICATIONS.....	4
3.1.	AES AUDIO INPUTS.....	4
3.2.	AES AUDIO OUTPUTS.....	4
3.3.	ELECTRICAL.....	4
3.4.	PHYSICAL.....	4
4.	STATUS LEADS.....	5
5.	JUMPERS AND USER ADJUSTMENTS.....	6
5.1.	INPUT TERMINATION JUMPER.....	6
5.2.	SELECTING WHETHER LOCAL FAULTS WILL BE MONITORED BY THE GLOBAL FRAME STATUS.....	7

### Figures

Figure 1-1:	500DA-AESB Block Diagram.....	1
Figure 2-1:	500BAL-IO Rear Panel Adapter for 500DA-AESB.....	2
Figure 2-2:	500BAL-IO Rear Panel Adapter Installation.....	3
Figure 5-1:	LED and Jumper Locations.....	6

## REVISION HISTORY

<u>REVISION</u>	<u>DESCRIPTION</u>	<u>DATE</u>
1.0	Original Version	Mar 03
1.1	Fixed formatting and typos	Jul 07
1.2	Fixed typo in section 3.2. General cleanup.	Dec 08

Information contained in this manual is believed to be accurate and reliable. However, Evertz assumes no responsibility for the use thereof nor for the rights of third parties, which may be affected in any way by the use thereof. Any representations in this document concerning performance of Evertz products are for informational use only and are not warranties of future performance, either expressed or implied. The only warranty offered by Evertz in relation to this product is the Evertz standard limited warranty, stated in the sales contract or order confirmation form.

Although every attempt has been made to accurately describe the features, installation and operation of this product in this manual, no warranty is granted nor liability assumed in relation to any errors or omissions unless specifically undertaken in the Evertz sales contract or order confirmation. Information contained in this manual is periodically updated and changes will be incorporated into subsequent editions. If you encounter an error, please notify Evertz Customer Service department. Evertz reserves the right, without notice or liability, to make changes in equipment design or specifications.

## 1. OVERVIEW

The 500DA-AESB is a four output reclocking and auto equalizing DA for unbalanced 110 ohm AES signals. The DA automatically equalizes up to 300m of Belden 1800B cable and provides reclocked outputs with sampling frequencies of 32kHz, 44.1kHz, 48kHz and 96kHz.

The 500DA-AESB card edge LED indicators provide quick and accurate assessment of the incoming signal integrity.

The 500DA-AESU is housed in the 500FR **exponent** Frame that will hold up to 16 modules.

### Features:

- Supports AES3-1992 standard for AES audio on 110 twisted pair cable
- Automatic equalization and reclock provide extended cable length compensation (>300m)
- Transformer coupled balanced input
- High impedance or 110 ohm termination on input (jumper selectable)
- 4 reclocked outputs provide jitter reduction
- Card edge indicators for AES present, Reclocker rate, and AES Validity bit
- Tally output to Frame Status connector for input error conditions

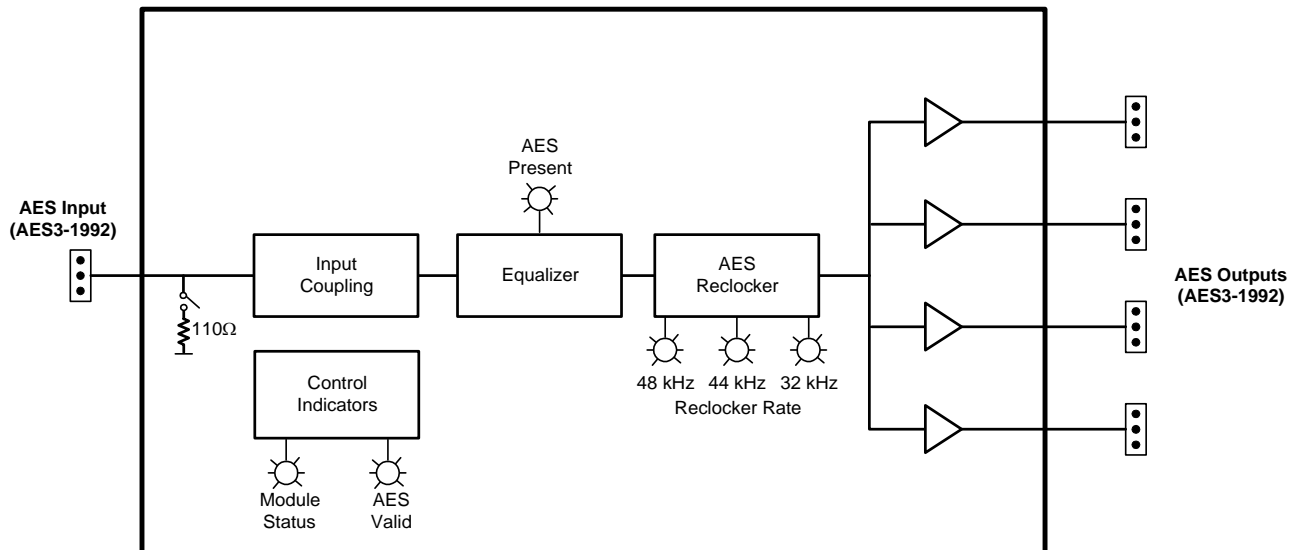

**Figure 1-1: 500DA-AESB Block Diagram**

## 2. INSTALLATION

The 500DA-AESB is shipped with a 500BAL-IO terminal block adapter that must be installed to the rear panel of the frame. For information on inserting the module into the frame see section 3 of the 500FR chapter.

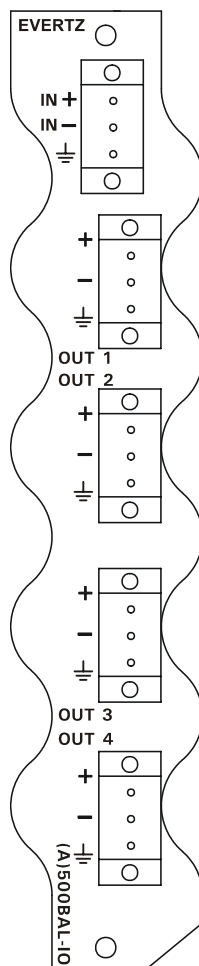

**Figure 2-1: 500BAL-IO Rear Panel Adapter for 500DA-AESB**

Refer to the pictures in Figure 2-2 for additional information on installing the panel adapter.

1. Using a Philips screwdriver, remove the screws above and below the slot where you want to install the panel adapter. (Figure 2-2a)
2. Install the two jack posts that were supplied with the panel adapter. Tighten with pliers or a hex wrench. (Figure 2-2b)
3. Slide the BNC connectors of the panel adapter over the BNC connectors on the rear of the frame. The panel adapter should go all the way in until it touched the jack posts.
4. Reinstall the screws and tighten with a Philips screwdriver. (See Figure 2-2c).

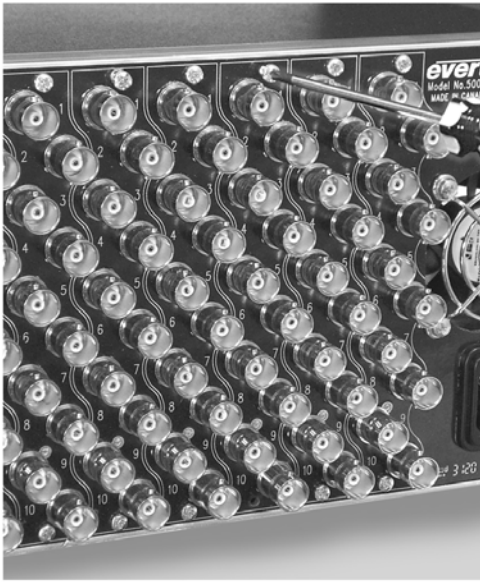
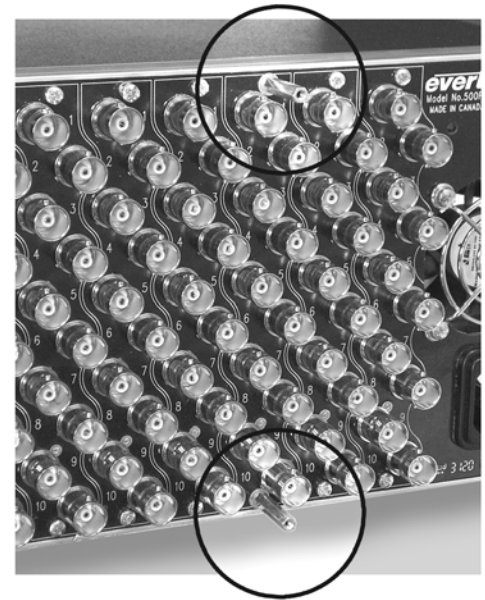
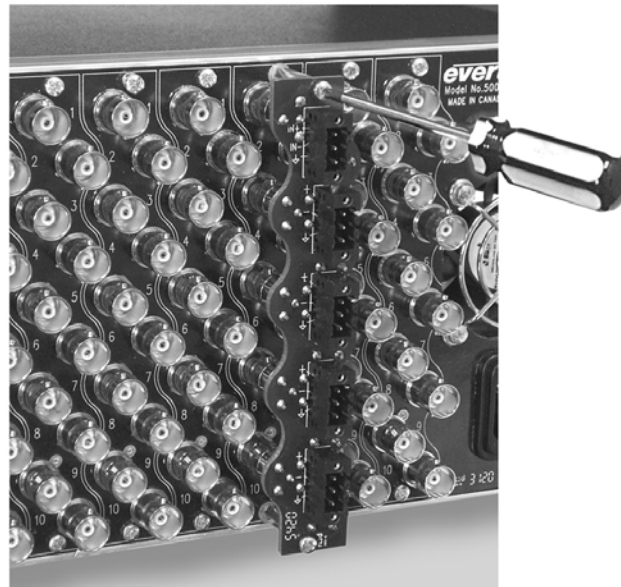
**(a) Removing the screws****(b) Installing the Jack Posts****(c) Securing the Panel Adapter screws****Figure 2-2: 500BAL-IO Rear Panel Adapter Installation**

The balanced AES cables can be secured into the removable portion of the terminal strips using a small screwdriver. The removable part of the terminal strip is then inserted into the terminal strips on the rear panel.

**IN:** Balanced AES audio input compatible with the AES3-1992 standard. The input (+, -, GND) is on a 3 pin removable terminal strip connector.

**OUT 1 to 4:** There are four balanced AES audio outputs compatible with the AES3-1992 standard. Each output (+, -, GND) is on a 3 pin removable terminal strip connector.

### 3. SPECIFICATIONS

#### 3.1. AES AUDIO INPUTS

<b>Standard:</b>	AES3-1992
<b>Number of Inputs:</b>	1
<b>Connector:</b>	3 pin removable terminal strip
<b>Input Level:</b>	2 to 7V p-p
<b>Coupling:</b>	Transformer
<b>Input Impedance:</b>	110 ohms
<b>Return Loss:</b>	>14dB 100kHz to 6MHz
<b>Equalization:</b>	Automatic to 300m with Belden 1800B (or equivalent) @ 48kHz AES signal
<b>Sampling Frequency:</b>	32kHz, 44.1kHz, 48kHz and 96kHz

#### 3.2. AES AUDIO OUTPUTS

<b>Number of Outputs:</b>	4 Balanced AES reclocked
<b>Connector:</b>	3 pin removable terminal strip
<b>Output Level:</b>	5V p-p
<b>Output Impedance:</b>	110 ohms
<b>Return Loss:</b>	>30dB 100kHz to 6MHz

#### 3.3. ELECTRICAL

<b>Voltage:</b>	+ 12VDC
<b>Power:</b>	5 Watts
<b>EMI/RFI:</b>	Complies with FCC Part 15 Class A EU EMC Directive

#### 3.4. PHYSICAL

<b>Number of slots:</b>	1
-------------------------	---

## 4. STATUS LEDES

The 500DA-AESB has seven LED Status indicators on the front card edge to show operational status of the card at a glance. Figure 5-1 shows the location of the LEDs.

Two large LEDs on the front of the board indicate the general health of the module:

**LOCAL FAULT:** This Red LED indicates poor module health and will be On during the absence of a valid input signal, or if a local input power fault exists (i.e.: a blown fuse). The LOCAL FAULT indication can also be reported to the frame through the FRAME STATUS jumper.

**MODULE OK:** This Green LED indicates good module health. It will be On when a valid input signal is present, and the board power is good.

There are five small LEDs that indicate the status of the input AES audio.

**AES PRESENT:** This LED will be On when there is an AES carrier present at the input to the module.

**48 kHz:** The reclocker is currently locked to 48 kHz

**44 kHz:** The reclocker is currently locked to 44.1 kHz

**32 kHz:** The reclocker is currently locked to 32 kHz

**AES VBIT:** This LED indicates the status of the AES validity bit. When the LED is Off it indicates that the AES sample data is suitable for conversion to an analog audio signal. When the LED is On it indicates that the AES sample data is carrying data such as Dolby E and is not suitable for conversion to an analog audio signal.

## 5. JUMPERS AND USER ADJUSTMENTS

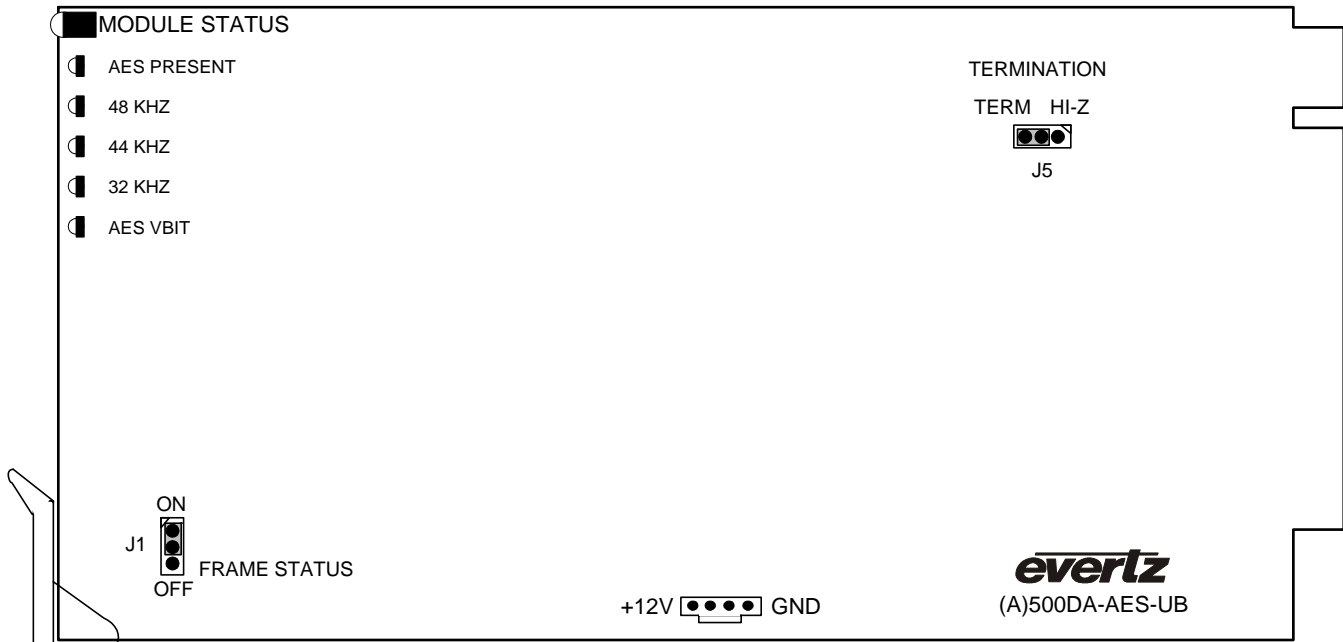

Figure 5-1: LED and Jumper Locations

### 5.1. INPUT TERMINATION JUMPER

The TERMINATION jumper J5, located at the rear of the module, determines whether the input signal will be terminated or not.

**TERMINATION:** When set in the "TERM" position, (default) the input impedance is set to 110 Ohms. Use this position when the cable stops at this card. It will provide the proper impedance to eliminate electrical reflections.

If set to "UNTERM", the input will be high impedance. Use this position when the signal does NOT stop at this card. Connect both input cables to the INPUT terminal strip to "loop" the signal through this card.



**WARNING:** Make sure that the final destination of the signal is terminated. Otherwise, reflections will occur affecting the signal throughout the cable.



## 5.2. SELECTING WHETHER LOCAL FAULTS WILL BE MONITORED BY THE GLOBAL FRAME STATUS

The FRAME STATUS jumper J1, located at the front of the module determines whether local faults (as shown by the Local Fault indicator) will be connected to the 500FR frame's global status bus.

**FRAME STATUS:** To monitor faults on this module with the frame status indicators (on the power supply's FRAME STATUS LED's and on the Frame's Fault Tally output) install this jumper in the On position.

When this jumper is installed in the Off position local faults on this module will not be monitored.

*This page left intentionally blank*