

---

---

## TABLE OF CONTENTS

1.	OVERVIEW.....	1
2.	INSTALLATION.....	3
2.1.	500DA-3G CONNECTIONS .....	3
3.	SPECIFICATIONS.....	4
3.1.	SERIAL VIDEO INPUT .....	4
3.2.	SERIAL VIDEO OUTPUT .....	4
3.3.	ELECTRICAL .....	4
3.4.	PHYSICAL .....	4
4.	STATUS LEADS .....	5
5.	JUMPERS AND USER ADJUSTMENTS.....	6
5.1.	SELECTING WHETHER LOCAL FAULTS WILL BE MONITORED BY THE GLOBAL FRAME STATUS.....	6
5.2.	SELECTING NON-RECLOCK MODE.....	7
6.	VISTALINK® REMOTE MONITORING/CONTROL.....	8
6.1.	WHAT IS VISTALINK®? .....	8
6.2.	MONITOR SETTINGS TAB.....	9
6.2.1.	Lock Status .....	9
6.2.2.	Bypass Select .....	9
6.2.3.	Input Video Rate .....	9
6.3.	FAULT TRAPS TAB.....	10
6.3.1.	Module OK Trap Status.....	10

### Figures

Figure 1-1:	500DA-3G Block Diagram .....	2
Figure 2-1:	500DA-3G Rear Panel Overlay .....	3
Figure 5-1:	LED and Jumper Locations .....	6
Figure 5-1:	VistaLINK® 500DA-3G Monitor Status Tab.....	9
Figure 5-1:	VistaLINK® 500DA-3G Fault Traps Tab.....	10

## REVISION HISTORY

<u>REVISION</u>	<u>DESCRIPTION</u>	<u>DATE</u>
1.0	Original Version	Apr 2009
2.0	Updated for Rev 2 Hardware and corrected jumper labels	Jan 2011

Information contained in this manual is believed to be accurate and reliable. However, Evertz assumes no responsibility for the use thereof nor for the rights of third parties, which may be affected in any way by the use thereof. Any representations in this document concerning performance of Evertz products are for informational use only and are not warranties of future performance, either expressed or implied. The only warranty offered by Evertz in relation to this product is the Evertz standard limited warranty, stated in the sales contract or order confirmation form.

Although every attempt has been made to accurately describe the features, installation and operation of this product in this manual, no warranty is granted nor liability assumed in relation to any errors or omissions unless specifically undertaken in the Evertz sales contract or order confirmation. Information contained in this manual is periodically updated and changes will be incorporated into subsequent editions. If you encounter an error, please notify Evertz Customer Service department. Evertz reserves the right, without notice or liability, to make changes in equipment design or specifications.

## 1. OVERVIEW

The 500DA-3G reclocking distribution amplifier provides inexpensive distribution of your SMPTE 424M, SMPTE 292M and SMPTE 259M serial digital video signals at rates of 3Gb/s, 1.5Gb/s and 270Mb/s. The DA supports all other SMPTE 344M, SMPTE 259M, SMPTE 310M and DVB-ASI data rates in a non-reclocked mode (540Mb/s, 360Mb/s, 143Mbs/, 19.4Mb/s).

Ideal in applications where a large quantity of outputs are required, the DA features an auto-equalized input with eight isolated reclocked outputs.

The 500DA-3G is housed in the 3RU 500FR exponent frame that will hold up to 16 cards.

### Features:

- Normal reclocked mode for SMPTE 424M (3Gb/s), SMPTE 292M (1.5Gb/s) and SMPTE 259M (270Mb/s)
- Jumper selectable non-reclocked mode for all other SMPTE 344M, SMPTE 259M, SMPTE 310M and DVB-ASI data rates
- Fully hot-swappable from front of frame with no BNC disconnect required
- Independent isolated output drivers to ensure no cross channel loading effects (i.e. no need to terminate unused outputs)
- Outputs maintain polarity from input to output for DVB-ASI applications
- Tally output on Frame Status bus upon loss of input signal for quality monitoring
- VistaLINK<sup>®</sup>-capable for remote monitoring via SNMP (using VistaLINK<sup>®</sup>PRO) when installed in 500FR frame with 500FC VistaLINK<sup>®</sup>Frame Controller

### Input:

- SMPTE 424M (3Gb/s), SMPTE 292M (1.5Gb/s), SMPTE 259M (270Mb/s) when re-clocking
- SMPTE 344M (540Mb/s), SMPTE 259 (360Mb/s, 143Mb/s), SMPTE 310M (19.4Mb/s), DVB-ASI when not re-clocking
- Return Loss > 15dB to 1.5GHz and > 10dB up to 3GHz
- Auto equalization to 80m at 3Gb/s, 140m @ 1.5Gb/s and 350m @ 270Mb/s

### Outputs:

- 8 reclocked outputs
- Return Loss > 15dB to 1.5GHz
- Wideband jitter < 0.2 UI

### Card Edge LEDs:

- Reclocker rate (3 LEDS)
- Reclocker locked
- Reclocker bypass
- Module Health Status

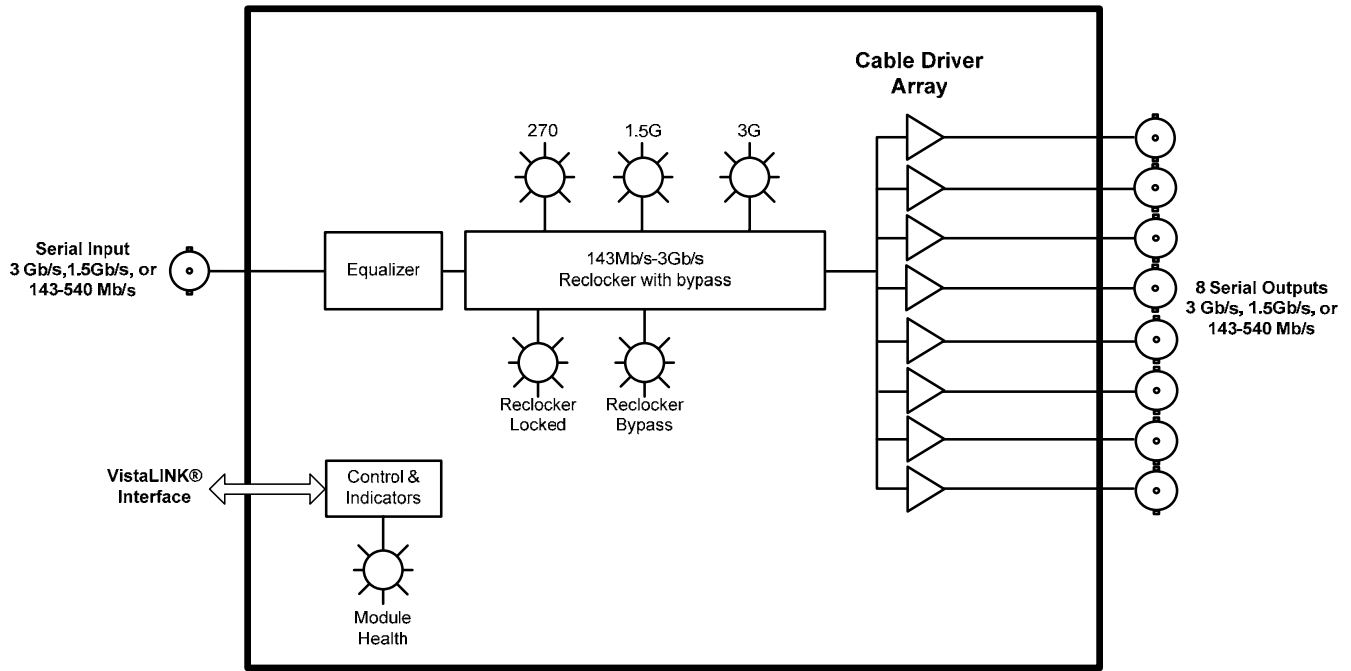

**Figure 1-1: 500DA-3G Block Diagram**

## 2. INSTALLATION

The 500DA-3G series modules come with a companion rear panel overlay that can be placed over the rear panel BNC connectors to identify their function. For information on inserting the module into the frame see section 3 of the 500FR chapter.

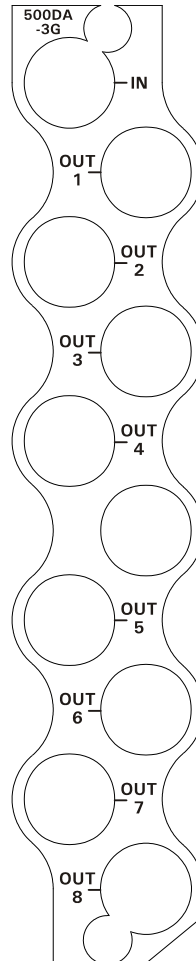

**Figure 2-1: 500DA-3G Rear Panel Overlay**

### 2.1. 500DA-3G CONNECTIONS

**IN:** Input BNC connector for 10-bit serial digital video signals compatible with the SMPTE 259M, DVB-ASI or SMPTE 292M standard. This input is terminated with 75 ohms.

**OUT 1 to 8:** There are eight BNC connectors with reclocked serial component video outputs, compatible with the SMPTE 259M / DVB-ASI, or SMPTE 292M standard.



**BNC 6 is not used. Outputs are on BNC's 2-5 and 7-10.**

### 3. SPECIFICATIONS

#### 3.1. SERIAL VIDEO INPUT

**Reclocked Mode:** SMPTE 424M (3Gb/s)  
SMPTE 292M (1.5Gb/s)  
SMPTE 259M (270Mb/s)

**Non Reclocked Mode:**  
SMPTE 344M (540Mb/s)  
SMPTE 259M (360Mb/s, 143Mb/s)  
SMPTE 310M (19.4Mb/s), DVB-ASI

**Connector:** BNC per IEC 61169-8 Annex A

**Equalization:** Automatic to 65m @ 3Gb/s, 125m @ 1.5Gb/s & 350m @ 270Mb/s

**Return Loss:** > 15dB up to 1.5GHz  
> 10dB up to 3GHz

#### 3.2. SERIAL VIDEO OUTPUT

**Number of Outputs:** 8 Reclocked

**Connector:** BNC per IEC 61169-8 Annex A

**DC Offset:** 0V  $\pm$  0.5V

**Rise and Fall Time:** 135ps @ 3G  
270ps @ HD  
700ps @ SD nominal

**Return Loss:** > 15dB up to 1.5GHz

**Wideband Jitter:** < 0.2 UI HD  
< 0.3 UI 3G

#### 3.3. ELECTRICAL

**Voltage:** + 12VDC

**Power:** 5 Watts

**EMI/RFI:** Complies with FCC Part 15 Class A, EU EMC Directive

#### 3.4. PHYSICAL

**Number of slots:** 1

## 4. STATUS LEDES

The 500DA-3G series DA has seven LED Status indicators on the front card edge to show operational status of the card at a glance. Figure 5-1 shows the location of the LEDs.

Two large LEDs on the front of the board indicate the general health of the module:

**LOCAL FAULT:** This Red LED indicates poor module health and will be On during the absence of a valid input signal, or if a local input power fault exists (i.e.: a blown fuse). The LOCAL FAULT indication can also be reported to the frame through the FRAME STATUS jumper.

**MODULE OK:** This Green LED indicates good module health. It will be On when a valid input signal is present, and the board power is good.

There are five small LEDs that indicate the status of the equalizer and reclocker.

**LOCK:** This Green LED will be On when there is a valid signal present at the module input.

**RECLOCKER BYPASS:** This Green LED will be On when the reclocker rate is disabled by jumper J2.

**RECLOCKER RATE:** There are 3 LEDs that indicate the rate (270, 1.5 Gb/s or 3 Gb/s) that the reclocker is currently using.

## 5. JUMPERS AND USER ADJUSTMENTS

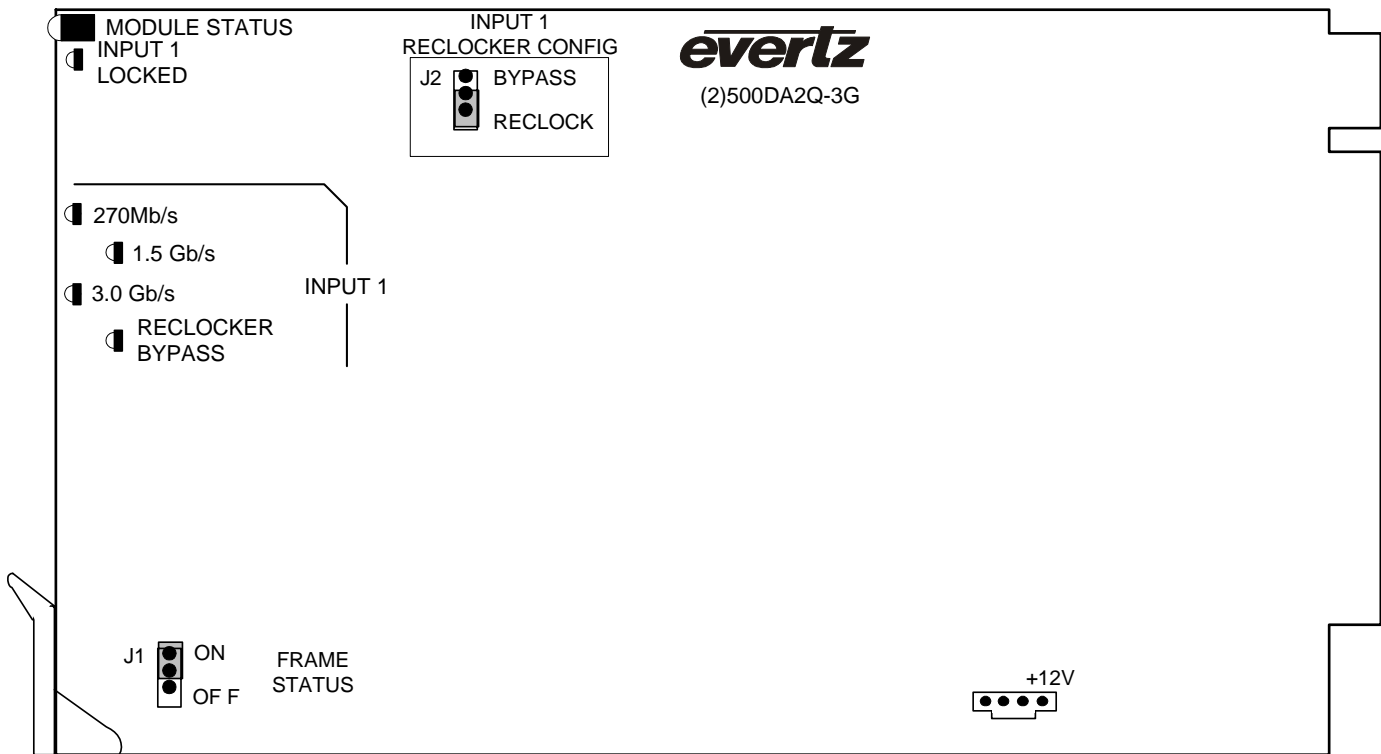

Figure 5-1: LED and Jumper Locations

### 5.1. SELECTING WHETHER LOCAL FAULTS WILL BE MONITORED BY THE GLOBAL FRAME STATUS

The FRAME STATUS jumper J1, located at the front of the module, determines whether local faults (as shown by the Local Fault indicator) will be connected to the 500FR frame's global status bus.

**FRAME STATUS:** To monitor faults on this module with the frame status indicators (on the power supply's FRAME STATUS LED's and on the Frame's Fault Tally output) install this jumper in the On position.

When this jumper is installed in the Off position local faults on this module will not be monitored.



## 5.2. SELECTING NON-RECLOCK MODE

The BYPASS SELECT jumper J2, located at the front of the module, determines whether the module will operate as a reclocking amplifier with SMPTE 292M (1.5 Gb/s), SMPTE 259M or 344M (143 to 540 Mb/s) or DVB-ASI video signals or as a non-reclocking distribution amplifier with other data rates.

**BYPASS SELECT:** To operate the module in reclocking mode, install the jumper in the RECLOCK position.

To operate the module in non-reclocking mode, install the jumper in the BYPASS position.

## 6. VistaLINK<sup>®</sup> REMOTE MONITORING/CONTROL

### 6.1. WHAT IS VistaLINK<sup>®</sup>?

VistaLINK<sup>®</sup> is Evertz's remote monitoring and configuration platform which operates over an Ethernet network using Simple Network Management Protocol (SNMP). SNMP is a standard computer network protocol that enables different devices sharing the same network to communicate with each other. VistaLINK<sup>®</sup> provides centralized alarm management, which monitors, reports, and logs all incoming alarm events and dispatches alerts to all the VLPro Clients connected to the server. Card configuration through VistaLINK<sup>®</sup> PRO can be performed on an individual or multi-card basis using simple copy and paste routines, which reduces the time to configure each module separately. Finally, VistaLINK<sup>®</sup> enables the user to configure devices in the network from a central station and receive feedback that the configuration has been carried out.

There are 3 components of SNMP:

1. An SNMP manager, also known as a Network Management System (NMS), is a computer running special software that communicates with the devices in the network. Evertz VistaLINK<sup>®</sup> Pro Manager graphical user interface (GUI), third party or custom manager software may be used to monitor and control Evertz VistaLINK<sup>®</sup> enabled products.
2. Managed devices (such as 500DA-3G), each with a unique address (OID), communicate with the NMS through an SNMP Agent. Evertz VistaLINK<sup>®</sup> enabled 500 series modules reside in the 3RU 500FR or 500FR-L-D **exponent** Frame and communicate with the manager via the 500FC VistaLINK<sup>®</sup> frame controller module, which serves as the Agent.
3. A virtual database, known as the Management Information Base (MIB), lists all the variables being monitored, which both the Manager and Agent understand. Please contact Evertz for further information about obtaining a copy of the MIB for interfacing to a third party Manager/NMS.

For more information on connecting and configuring the VistaLINK<sup>®</sup> network, see the 500FC Frame Controller chapter.

**6.2. Monitor Settings Tab**

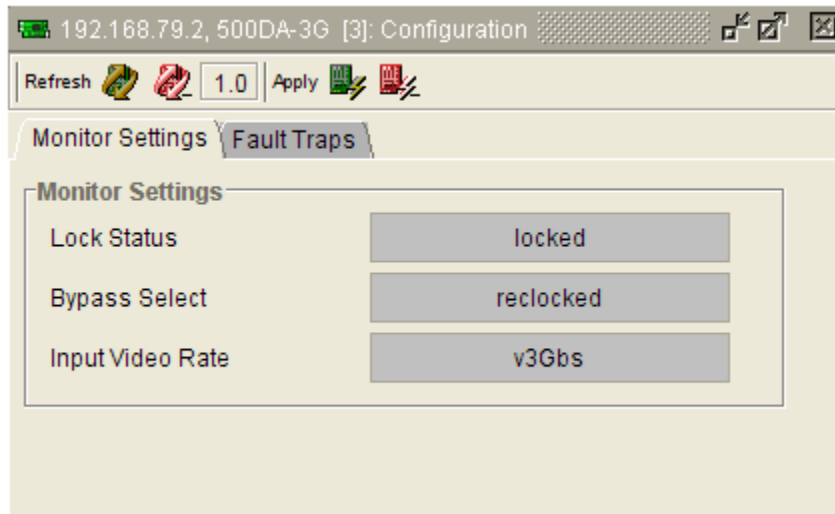

**Figure 6-1: VistaLINK® 500DA-3G Monitor Status Tab**

**6.2.1. Lock Status**

Monitor Settings
Monitor Settings
Lock Status
locked
not locked

Displays the current status of the video input reclocker.

**6.2.2. Bypass Select**

Monitor Settings
Monitor Settings
Bypass Select
reclocked
bypassed

Displays the operating state of the video input reclocker.

**6.2.3. Input Video Rate**

Monitor Settings
Monitor Settings
Input Video Rate
not valid
270M
1.5 Gbs
3Gbs

Displays the detected input video rate.

### 6.3. Fault Traps Tab

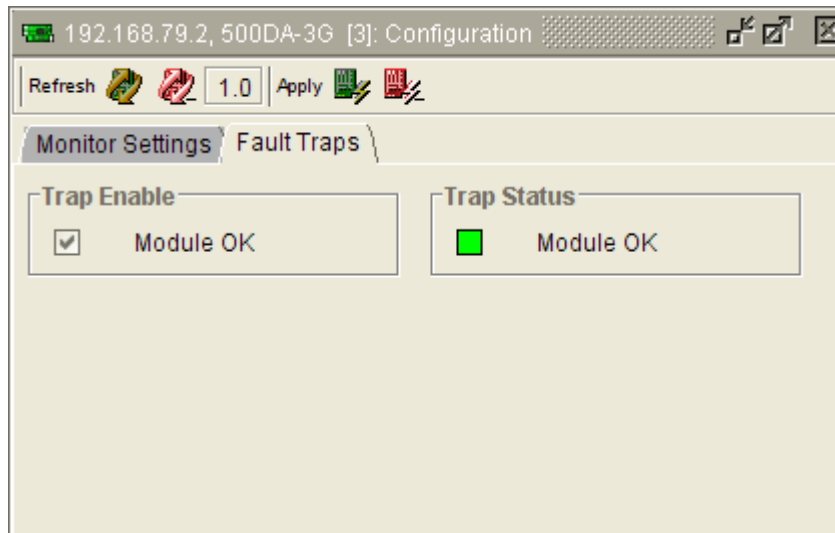

**Figure 6-2: VistaLINK® 500DA-3G Fault Traps Tab**

#### 6.3.1. Module OK Trap Status

<i>Fault Traps</i>
<i>Trap Status</i>
<i>Module OK</i>

Indicates the current status of the module (same state as Module Fault LED).