TABLE OF CONTENTS

1.	OVERVIEW.....	1
2.	INSTALLATION.....	2
3.	SPECIFICATIONS.....	3
3.1.	SERIAL VIDEO INPUT	3
3.2.	SERIAL VIDEO OUTPUTS.....	3
3.3.	ELECTRICAL	3
3.4.	PHYSICAL	3
4.	STATUS LEADS.....	4
5.	JUMPERS AND USER ADJUSTMENTS.....	5
5.1.	SELECTING WHETHER LOCAL FAULTS WILL BE MONITORED BY THE GLOBAL FRAME STATUS.....	6
5.2.	SELECTING THE RECLOCKING RATE	6

Figures

Figure 1-1:	500DA Block Diagram.....	1
Figure 2-1:	500DA Rear Panel Overlay.....	2
Figure 5-1:	LED and Jumper Locations	5

REVISION HISTORY

<u>REVISION</u>	<u>DESCRIPTION</u>	<u>DATE</u>
1.0	Original Version	Aug 02
1.1	Corrected cable equalization figures	Dec 02
1.2	Updated specifications, reformatting	Feb 03
1.3	Fixed formatting and typos	May 08

Information contained in this manual is believed to be accurate and reliable. However, Evertz assumes no responsibility for the use thereof nor for the rights of third parties, which may be effected in any way by the use thereof. Any representations in this document concerning performance of Evertz products are for informational use only and are not warranties of future performance, either express or implied. The only warranty offered by Evertz in relation to this product is the Evertz standard limited warranty, stated in the sales contract or order confirmation form.

Although every attempt has been made to accurately describe the features, installation and operation of this product in this manual, no warranty is granted nor liability assumed in relation to any errors or omissions unless specifically undertaken in the Evertz sales contract or order confirmation. Information contained in this manual is periodically updated and changes will be incorporated into subsequent editions. If you encounter an error, please notify Evertz Customer Service department. Evertz reserves the right, without notice or liability, to make changes in equipment design or specifications.

1. OVERVIEW

The Evertz 500DA Reclocking Distribution Amplifier provides inexpensive distribution of your SMPTE 310M and SMPTE 259M serial digital video signal at rates of 19.4 Mb/s and 143 Mb/s to 540 Mb/s in applications where a large quantity of outputs are required. The DA features an auto-equalized input with nine reclocked outputs.

The 500DA has been designed for use as a SMPTE 310M (19.4 Mb/s), DVB-ASI or SMPTE 259M distribution product. SMPTE 310M support is selected by setting a rate select jumper.

The 500DA is housed in the 3RU 500FR **exponent** Frame that will hold up to 16 modules.

Features:

- Normal mode for SMPTE 259M (143 to 360 Mb/s), SMPTE 344M (540 Mb/s) or DVB-ASI signals - autodetects correct bitrate
- Jumper Selectable mode for SMPTE 310M (19.4 Mb/s)
- Fully hot-swappable from front of frame with no BNC disconnect required
- Independent isolated output drivers to ensure no cross channel loading effects (i.e. no need to terminate unused outputs)
- Outputs maintain polarity from input to output for DVB-ASI applications.
- Tally output on Frame Status bus upon loss of input signal for quality monitoring

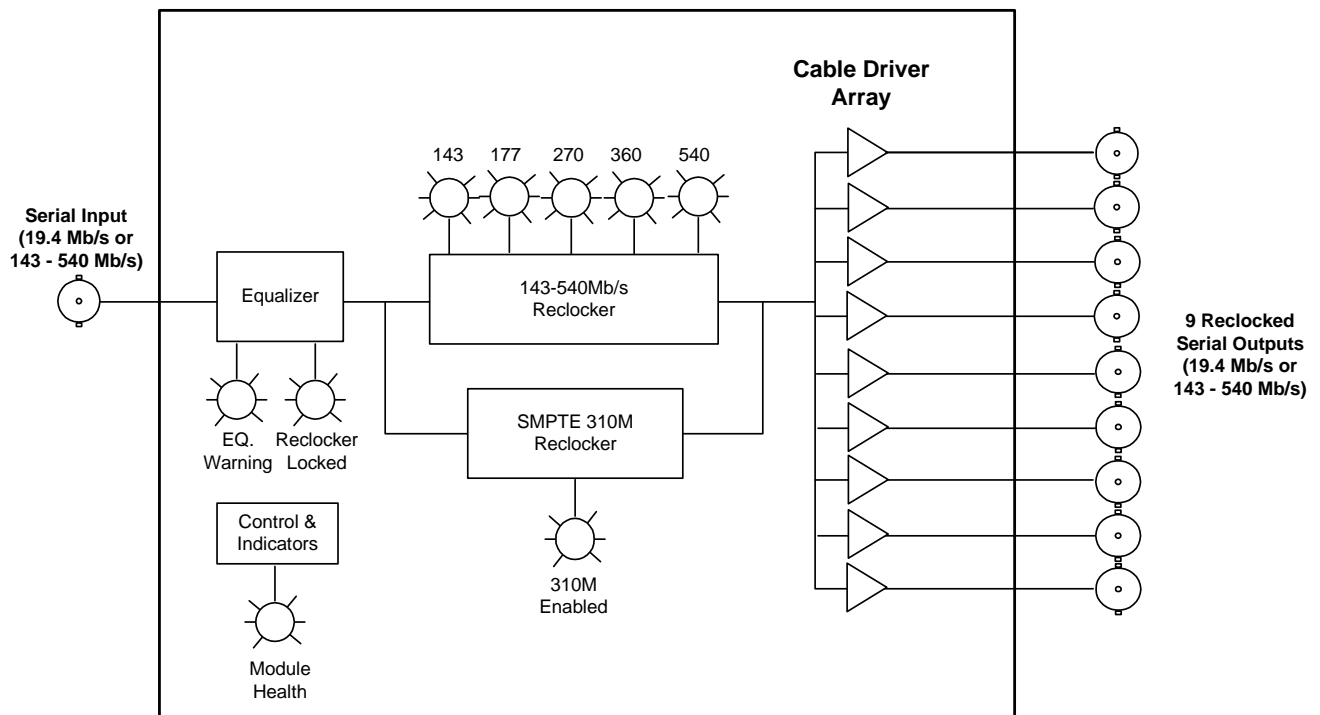

Figure 1-1: 500DA Block Diagram

2. INSTALLATION

The 500DA comes with a companion rear panel overlay that can be placed over the rear panel BNC connectors to identify their function. For information on inserting the module into the frame see section 3 of the 500FR chapter.

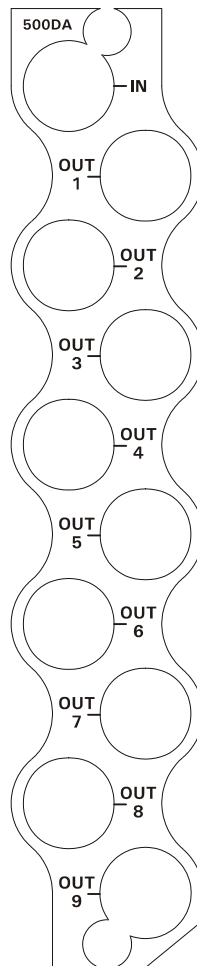

Figure 2-1: 500DA Rear Panel Overlay

IN Input BNC connector for 10-bit serial digital video signals compatible with the SMPTE 259M, DVB-ASI or SMPTE 310M standard. See section 5.2 for information on choosing the correct video standard.

OUT 1 to 9 There are nine BNC connectors with reclocked serial component video outputs, compatible with the SMPTE 259M / DVB-ASI, or SMPTE 310M standard.

3. SPECIFICATIONS

3.1. SERIAL VIDEO INPUT

Standards:

259 Mode: SMPTE 259M A, B, C, D (143 to 360 Mb/s), SMPTE 344M (540 Mb/s) or DVB-ASI

310 Mode: SMPTE 310M (19.4 Mb/s)

Connector: 1 BNC per IEC 169-8

Equalization: Automatic to 440m @ 270 Mb/s with Belden 1694A or equivalent cable
(380m with HD-SDI modules within 500 FR frame)

Return Loss: > 15 dB up to 540 Mb/s

3.2. SERIAL VIDEO OUTPUTS

Number of Outputs: 9 Reclocked

Connector: BNC per IEC 169-8

Signal Level: 800mV nominal

DC Offset: 0V \pm 0.5V

Rise and Fall Time: 470ps nominal

Overshoot: < 10% of amplitude

Return Loss: > 15 dB up to 540 Mb/s

Wide Band Jitter: < 0.2 UI

3.3. ELECTRICAL

Voltage: + 12VDC

Power: 6 Watts

EMI/RFI: Complies with FCC Part 15 Class A, EU EMC Directive

3.4. PHYSICAL

Number of slots: 1

4. STATUS LEDES

The 500DA has ten LED Status indicators on the front card edge to show operational status of the card at a glance. Figure 5-1 shows the location of the LEDs.

Two large LEDs on the front of the board indicate the general health of the module

LOCAL FAULT: This Red LED indicates poor module health and will be On during the absence of a valid input signal or if a local input power fault exists (i.e.: a blown fuse). The LOCAL FAULT indication can also be reported to the frame through the FRAME STATUS jumper.

MODULE OK: This Green LED indicates good module health. It will be On when a valid input signal is present, and board power is good.

There are eight small LEDs that indicate the status of the equalizer and reclocker.

LOCK: This Green LED will be On when there is a valid signal present at the module input.

CABLE LENGTH WARNING: This Yellow LED will be On when the cable equalizer detects that the cable length is greater than a preset threshold (factory set for 250 meters of Belden 8281 or equivalent cable).

RELOCKER RATE: There are 5 LEDs that indicate the rate (143, 177, 270, 360 or 540 Mb/s) that the reclocker is currently using when the Rate jumper is set to the 259M/344M position.

310M ENABLE: This Green LED will be On when the SMPTE 310M reclocker rate is selected by jumper J3.

5. JUMPERS AND USER ADJUSTMENTS

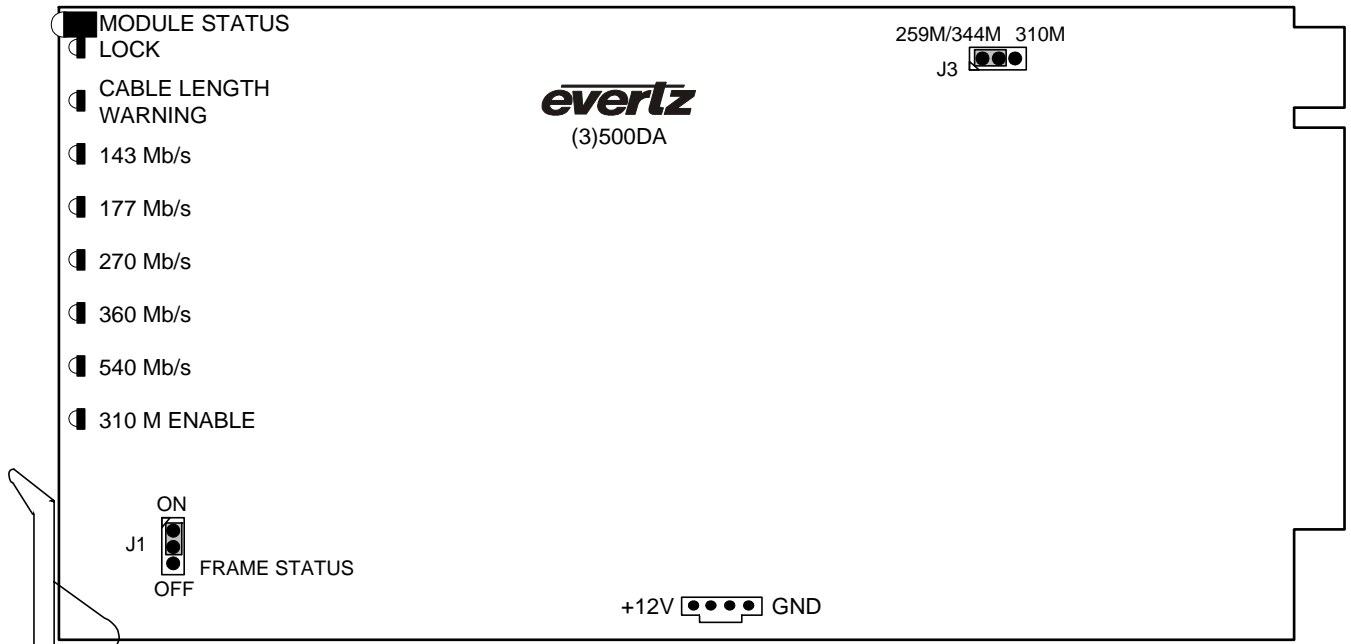

Figure 5-1: LED and Jumper Locations

5.1. SELECTING WHETHER LOCAL FAULTS WILL BE MONITORED BY THE GLOBAL FRAME STATUS

The FRAME STATUS jumper J1, located at the front of the module determines whether local faults (as shown by the Local Fault indicator) will be connected to the 500FR frame's global status bus.

FRAME STATUS: To monitor faults on this module with the frame status indicators (on the power supply's FRAME STATUS LED's and on the Frame's Fault Tally output) install this jumper in the On position.

When this jumper is installed in the Off position local faults on this module will not be monitored.

5.2. SELECTING THE RECLOCKING RATE

The RATE SELECT jumper J2, located at the top rear of the module, determines whether the module will operate as a reclocking distribution amplifier with SMPTE 259M or 344M (143 to 540 Mb/s) or DVB-ASI video signals or with SMPTE 310M (19.4 Mb/s) signals.

RATE SELECT: To set the module to operate with SMPTE 259M, SMPTE 344M or DVB-ASI signals, install the jumper in the 259M/344M position.

To set module to operate with SMPTE 310M signals install the jumper in the 310M position.