

TABLE OF CONTENTS

| | | |
|------|---|---|
| 1. | OVERVIEW..... | 1 |
| 2. | INSTALLATION..... | 2 |
| 3. | SPECIFICATIONS..... | 3 |
| 3.1. | WORD CLOCK INPUT | 3 |
| 3.2. | WORD CLOCK OUTPUTS..... | 3 |
| 3.3. | ELECTRICAL | 3 |
| 3.4. | PHYSICAL..... | 3 |
| 4. | STATUS LEADS..... | 4 |
| 5. | JUMPERS AND USER ADJUSTMENTS..... | 5 |
| 5.1. | SELECTING WHETHER LOCAL FAULTS WILL BE MONITORED BY THE GLOBAL FRAME STATUS..... | 5 |
| 5.2. | SELECTING THE INPUT TERMINATION..... | 5 |
| 5.3. | GAIN ADJUSTMENT..... | 5 |

Figures

| | | |
|-------------|-----------------------------------|---|
| Figure 1-1: | 500ADA-W Block Diagram | 1 |
| Figure 2-1: | 500ADA-W Rear Panel Overlay | 2 |
| Figure 5-1: | LED and Jumper Locations | 5 |

REVISION HISTORY

| <u>REVISION</u> | <u>DESCRIPTION</u> | <u>DATE</u> |
|-----------------|----------------------------|-------------|
| 1.0 | Original Version | Mar 03 |
| 1.1 | Fixed formatting and typos | Jul 07 |

Information contained in this manual is believed to be accurate and reliable. However, Evertz assumes no responsibility for the use thereof nor for the rights of third parties, which may be effected in any way by the use thereof. Any representations in this document concerning performance of Evertz products are for informational use only and are not warranties of future performance, either express or implied. The only warranty offered by Evertz in relation to this product is the Evertz standard limited warranty, stated in the sales contract or order confirmation form.

Although every attempt has been made to accurately describe the features, installation and operation of this product in this manual, no warranty is granted nor liability assumed in relation to any errors or omissions unless specifically undertaken in the Evertz sales contract or order confirmation. Information contained in this manual is periodically updated and changes will be incorporated into subsequent editions. If you encounter an error, please notify Evertz Customer Service department. Evertz reserves the right, without notice or liability, to make changes in equipment design or specifications.

1. OVERVIEW

The 500ADA-W is a distribution amplifier for SDIF-2 Word Clock and other TTL level signals. The 500ADA-W features one input that can be high impedance or 75 ohm terminated and has nine outputs. The 500ADA-W provides continuous voltage gain adjustment from -6dB to $+6\text{dB}$ up to a maximum output signal level of 5 volts into a 75 ohm load or 10 volts into a high impedance load.

The 500ADA-W is housed in the 500FR **exponent** Frame that will hold up to 16 modules.

Features:

- Jumper selectable 75 Ohm or high impedance (1 kohm typical) input
- Voltage gain adjustment range from -6dB to $+6\text{dB}$
- Outputs can drive 5 volts into 75 ohm loads or 10 volts into high impedance loads

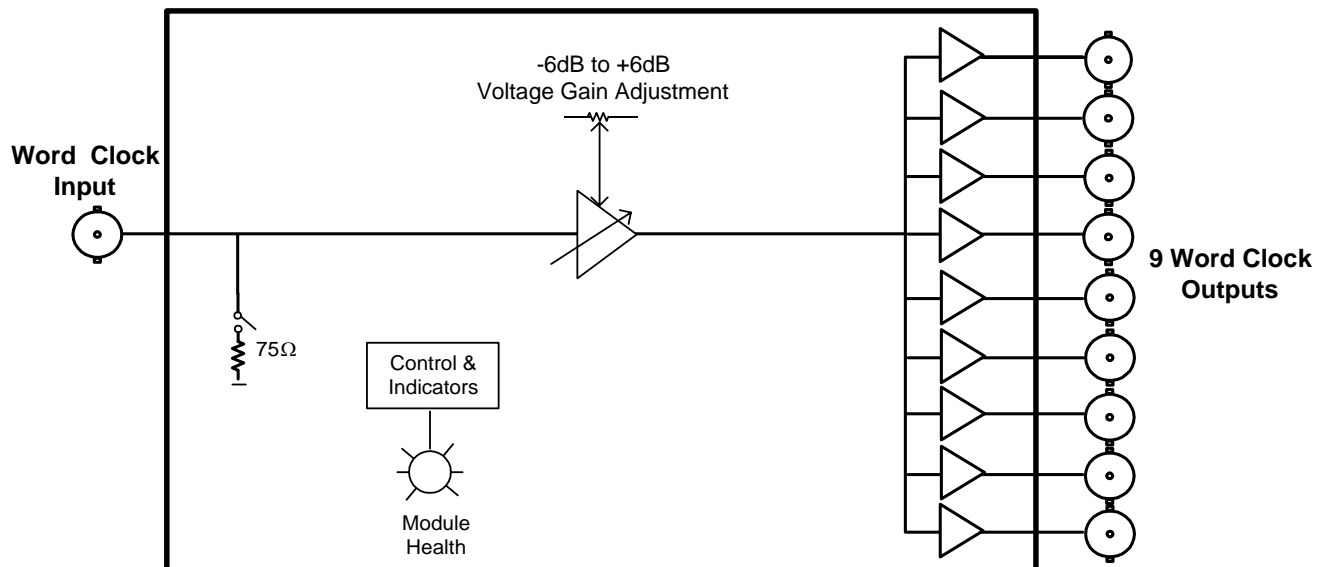

Figure 1-1: 500ADA-W Block Diagram

2. INSTALLATION

The 500ADA-W comes with a companion rear panel overlay that can be placed over the rear panel BNC connectors to identify their function. For information on inserting the module into the frame see section 3 of the 500FR chapter.

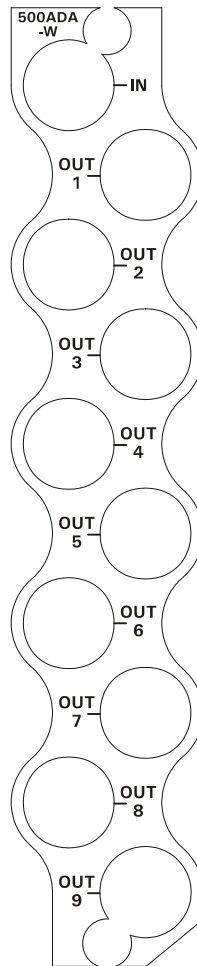

Figure 2-1: 500ADA-W Rear Panel Overlay

IN Input BNC connector for SDIF-2 Word Clock and other TTL level signals. The TERM jumper, located on the module near the back, determines whether the input signal will be high impedance or terminated with 75 ohms. (See section 5.2)

OUT 1 to 9 There are nine BNC connectors with level adjusted copies of the input signal.

3. SPECIFICATIONS

3.1. WORD CLOCK INPUT

| | |
|--------------------------|---|
| Standards: | SDIF-2 Word Clock |
| Connector: | 1 BNC input per IEC 169-8 |
| Signal amplitude: | 0 to 5 volts (terminated or unterminated) |
| Impedance: | 75 Ohms terminated, 1 kOhm Hi-Z (jumper selectable) |

3.2. WORD CLOCK OUTPUTS

| | |
|----------------------------|---|
| Number of Outputs: | 9 Per Card |
| Connector: | BNC per IEC 169-8 |
| Output impedance: | 75 Ohm |
| Output Level: | |
| Minimum: | 0 V |
| Maximum: | 5 V into 75 ohm load 10 V into high impedance load |
| Voltage Gain range: | ± 6dB |
| Frequency Range: | 28 kHz to 100 kHz |

3.3. ELECTRICAL

| | |
|-----------------|---|
| Voltage: | + 12VDC |
| Power: | 6 Watts |
| EMI/RFI: | Complies with FCC Part 15 Class A, EU EMC Directive |

3.4. PHYSICAL

| | |
|-------------------------|---|
| Number of slots: | 1 |
|-------------------------|---|

4. STATUS LEDES

The 500ADA-W has two LED Status indicators on the front card edge to show operational status of the card at a glance. Figure 5-1 shows the location of the LEDs.

Two large LEDs on the front of the board indicate the general health of the module:

LOCAL FAULT: This Red LED indicates poor module health and will be On if a local input power fault exists (i.e.: a blown fuse). The LOCAL FAULT indication can also be reported to the frame through the FRAME STATUS jumper.

MODULE OK: This Green LED indicates good module health. It will be On when the board power is good.

5. JUMPERS AND USER ADJUSTMENTS



Figure 5-1: LED and Jumper Locations

5.1. SELECTING WHETHER LOCAL FAULTS WILL BE MONITORED BY THE GLOBAL FRAME STATUS

The FRAME STATUS jumper J1, located at the front of the module determines whether local faults (as shown by the Local Fault indicator) will be connected to the 500FR frame's global status bus.

FRAME STATUS: To monitor faults on this module with the frame status indicators (on the power supply's FRAME STATUS LED's and on the Frame's Fault Tally output) install this jumper in the On position.

When this jumper is installed in the Off position local faults on this module will not be monitored.

5.2. SELECTING THE INPUT TERMINATION

The input termination may be set via card jumper J5 to either 75 Ohms (default) or Hi-Z (1k Ohms). Set it to Hi-Z when using a "T" connector to loop the signal through several device inputs.

5.3. GAIN ADJUSTMENT

The **GAIN** POT on the cards front edge allows you to adjust the input signal level. Turning the POT clockwise will increase the gain.

This page left intentionally blank