



The EQX-IP18-IPG is an 18 channel hybrid EQX input module that will allow existing or new EQX routers the ability to be bridged to the IP world. This IP Gateway module is fully featured with the the ability for encapsulation and de-encapsulation of video signals over IP. There are 18 inputs to the EQX that can be selected from either baseband inputs or 10GE IP sources, each of the 18 inputs have a frame sync designed to re-time the input video signal to the EQX frame reference signal. The EQX-IP18-IPG can also de-embed the audio from the selected 18 input video signals for packetized TDM audio routing.

Like all other EQX input cards, the EQX-IP18-IPG is cooled by the EQX-FAN-BIN, fully hotswappable and accessed from the front of the EQX frame. The EQX router can be loaded with a maximum of 32 EQX-IP18-IPG modules providing square and non-square matrix configurations from as small as 18 inputs through to 576 inputs.

The EQX Input and IP Gateway Module provides a future proofing answer to SDI based router and infrastructure, allowing a smooth integration under the MAGNUM Unified Control system for Evertz' Software Defined Video Network (SDVN) solution.

The EQX-IP18-IPG hybrid input card provides a gateway to link into IP infrastructures as well as allow a more efficient way to tieline routers together. IP based video packetized and transported over fiber will provide greater density and longer distances than coax based solutions would yield, yet still maintaining the low latency and proper SDI SMPTE switching capabilities in the EQX.

For added system flexibility the EQX-IPG-DIN-RP can be used with a standard 18 input 3G and HD Green modules utilizing our IP ready adapter module.

Features & Benefits

- 18 SD/HD/3G SDI inputs
- 18 uncompressed IP inputs (de-encapsulators)
- 18 uncompressed IP outputs (encapsulators)
- 10GbE interfaces
- Full Audio demux (AVIP) for all sources (SDI or IP, 18 total), over TDM so that it can be routed/processed separately
- Control is made simple using MAGNUM Unified Control System
- **Fullly compatible with all EQX frame models**

- **Full frame sync for all sources (SDI or IP, 18 total)**
- 4 additional frames of delay can be added
- Output phase adjustment with respect to reference
- Input expansion in increments of 18, from 18 through to 576
- Access to all modules from front of the EQX
- All modules are hot-swappable
- Fan cooled by EQX-FAN-BIN

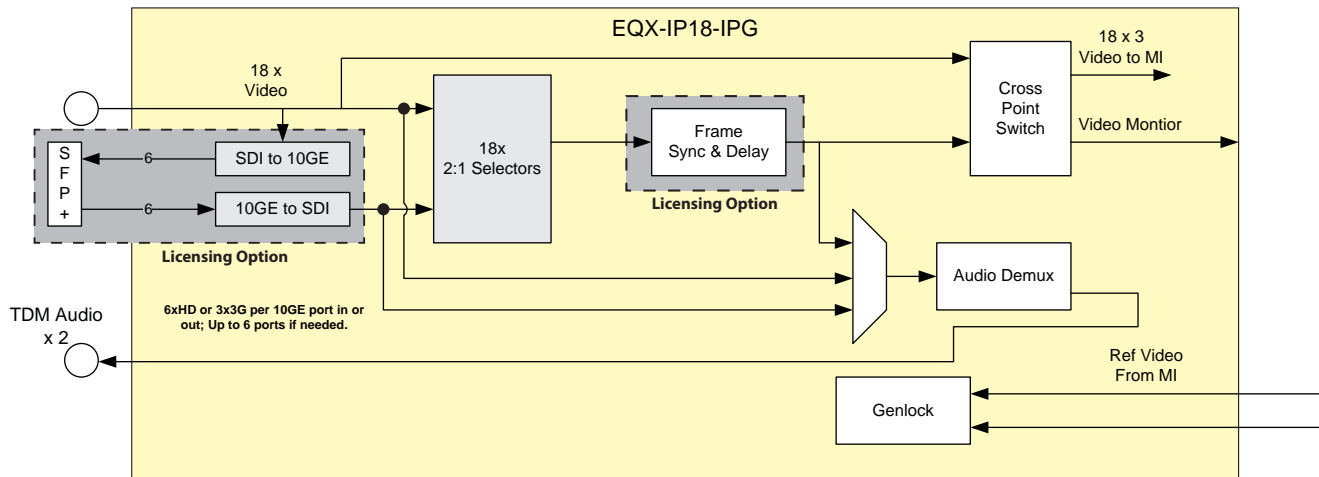

Specifications

Video Input: Formats: SMPTE ST 259, SMPTE ST 292-1, SMPTE ST 424, ASI, SMPTE 2022-6, ASPEN Number of video Inputs: 18	TDM Output: Number of TDM outputs: 2	Ethernet Interface: Ethernet/IP Signaling: Multicast IGMP V2/V3 Connectors: 6 SFP+
		Physical Module (number of slots in EQX Frame): 1

Ordering Information

EQX-IP18-IPG EQX Input and IP Gateway Module

SFP+ Modules:
+SFPTR13-10G 10GE optical 1310nm Network Transceiver
 Contact factory for additional interface options

Rear Panel:
EQX-IPG-DIN-RP Supports up to 2 EQX-IP18-IPG
 Contact factory for fiber input options

Licensing options:
+10GE (IP encapsulation, IP de-encapsulation, +FSE18 option is required)
+FSE18 (Frame Sync & Delay)

Future proofing IP ready solution using standard input card and IPG RP please contact factory for details