

7812HDC-HD, 7812HDC-AES8-HD, 7812HDC-3G, 7812HDC-AES8-3G

3G and HD Down Converters



The 7812HDC-HD and 7812HDC-AES8-HD are Broadcast Quality Down Converters that down convert common HD/ST 292-1 to common SD/SMPTE ST 259 video signals. -3G versions add support for common 3G/SMPTE 424M video signals. These modules support frame synchronization and external genlock inputs (card and frame reference) for video timing adjustments.

The 7812HDC series incorporates Mosquito Noise Reduction (MNR) and Block Artifact Reduction (BAR) in addition to motion adaptive spatial-temporal (3D) noise reduction. The 7812HDC series also incorporates new de-interlacing technologies for superior resolution and artifact reduction.

The 7812HDC series supports broadcast quality scaling and offers both standard and user defined ARC modes. AFD (SMPTE 2016) based steering of ARC modes and stamping AFD codes is fully supported. Transitions between AFD modes are frame accurate/glitch free. With the +F option, signals applied to PGM B IN can be keyed into image side panels. FILL inputs are frame synchronized so that pre-timing of FILL inputs is not required. With the +CF2G option, static or animated side panels can be stored locally and keyed into image side-panels.

Full broadcast quality color correction and detail enhancement processors are integrated in the 7812HDC series. RGB based color legalization is also supported. ITU Rec. 709 → 601 color space conversions are performed as needed.

The 7812HDC series supports 16 channels of embedded audio with audio delay automatically matching video delay. Additional audio delay is available. Full audio proc is supported including per channel audio gain, channel swapping and inversion controls. Surround sound to stereo (Lt/Rt or Lo/Ro) down-mixing is supported.

On -AES8 variants of the 7812HDC series, 8x discrete AES inputs and outputs are supported in addition to advanced audio processes like stereo to 5.1 up-mixing (+UMX), Dolby® E/AC-3 Decoding (+DD), Dolby® E Encoding (+DEE), Dolby® AC-3 Encoding (+AC3E) and IntelliGain Loudness Management (+IG). Any two Dolby® encode or decode functions may be integrated into a single card including dual decoders or dual encoders.

These modules transfer closed caption and time information from input to output performing all HD → SD data translations and time code re-calculations. SFP based fiber inputs and outputs can be supplied with the -F variations. (SFP modules ordered as separate accessories)

► Features & Benefits

- Broadcast quality down conversion of common HD/ST 292-1 video signals to common SD/SMPTE ST 259 video signals
- Support for common 3G/SMPTE 424M video signals (-3G versions)
- Integrated frame synchronization capabilities
- Support for card reference and 7800FR frame reference
- Advanced noise reduction technologies (3D NR, MNR, BAR)
- New generation de-interlacing technologies
- Supports standard and user defined aspect ratio conversions
- Fully AFD enabled with frame accurate transitions between AFD modes
- Integrated side panel fill keyer (+F)
- Optional compact flash for storage of side-panel content (+CF2G)
- Broadcast quality color corrector and detail enhancement engines
- ITU Rec 709 → 601 color space conversions
- "Soft Knee" color legalization (+ICL)
- 16 channel embedded audio support
- Audio delay automatically tracks video delay
- Full audio proc and channel swapping
- 5.1 surround sound to stereo (Lt/Rt and Lo/Ro) down-mixing
- Supports 8x external AES inputs and 8x AES outputs (-AES8 versions)
- Optional stereo to 5.1 surround sound up-mixer (+UMX on -AES8 versions)
- Optional Dolby® E/AC-3 decoder (+DD on -AES8 versions)
- Optional Dolby® E encoder (+DEE on -AES8 versions)
- Optional Dolby® AC-3 encoder (+AC3E on -AES8 versions)
- Optional IntelliGain Loudness Management (+IG on -AES8 versions)
- Transfers closed caption and time information from input to output with all required HD → SD data translations and time code re-calculations.
- Dual fiber in and dual fiber out using SFP modules (-F versions)
- SFP modules ordered as separate accessories
- VistaLINK® capable for remote monitoring, control and configuration capabilities via SNMP; using VistaLINK® PRO, CP-2116E or CP-2232E Control Panels. VistaLINK® is available when modules are used with the 3RU 7800FR frame and a 7700FC VistaLINK® Frame Controller module in slot 1 of the frame

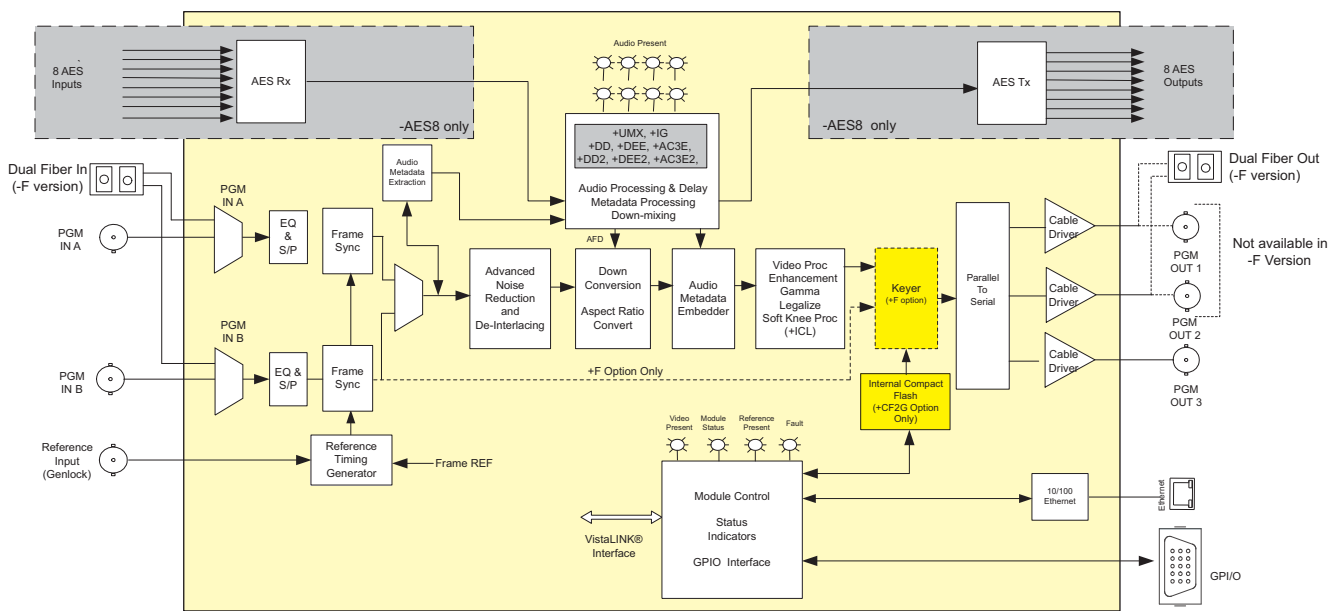

7812HDC-HD, 7812HDC-AES8-HD, 7812HDC-3G, 7812HDC-AES8-3G

3G and HD Down Converters

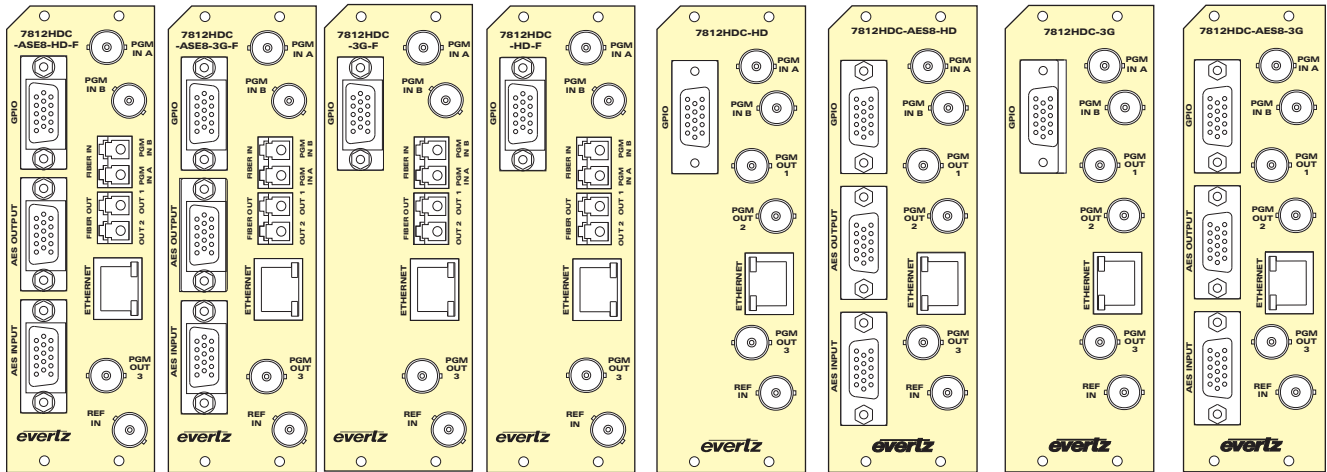

* When installed in the 7700FR-C modules occupy 3 slots. Card Slot blocker must be installed for operation in the 7700FR-C

Ordering Information

<p>Coax I/O: 7812HDC-HD HD Down Converter 7812HDC-AES8-HD HD Down Converter with AES I/O 7812HDC-3G 3G & HD Down Converter 7812HDC-AES8-3G 3G & HD Down Converter with AES I/O</p>	<p>+AC3E Dolby® AC-3 Encoder +DD2 Second Dolby® E/AC-3 Decoders +DEE2 Second Dolby® E Encoders +AC3E2 Second AC-3 Encoder</p>
<p>Fiber I/O Enabled: 7812HDC-HD-F HD Down Converter with Fiber I/O capability 7812HDC-AES8-HD-F HD Down Converter with AES and Fiber I/O capability 7812HDC-3G-F 3G & HD Down Converter with Fiber I/O capability 7812HDC-AES8-3G-F 3G & HD Down Converter with AES and Fiber I/O capability</p>	<p>Rear Plate Suffix +3RU 3RU Rear Plate for use with 350FR, 7700FR-C or 7800FR Multiframe</p>
<p>Ordering Options Rear Plate must be specified at time of order (Eg: Model + 3RU)</p> <p>+F Side Panel Fill +CF2G Embedded Compact Flash +ICL Soft Knee Color Legalizer</p>	<p>Accessories SFP3T13-2 Dual optical 3G/HD/SD-SDI SFP Transmitter, 1310 nm SFP3R-2 Dual optical 3G/HD/SD-SDI SFP Receiver 7700FC VistaLINK® Frame Controller CP-2116E-H Remote Control Panel CP-2232E Remote Control Panel</p>
<p>For -AES8 versions only +UMX Stereo to 5.1 Up-mix +IG IntelliGain Loudness Management (+IG) +DD Dolby® E/AC-3 Decoder +DEE Dolby® E Encoder</p>	<p>Enclosures 7800FR 3RU Multiframe which holds up to 15 single slot modules 7700FR-C 3RU Multiframe which holds up to 15 single slot modules 7801FR 1RU Multiframe which holds up to 4 single or 2 dual slot modules</p>

